

Unclassified**English - Or. English****5 August 2021****ENVIRONMENT DIRECTORATE
JOINT MEETING OF THE CHEMICALS COMMITTEE AND THE WORKING PARTY ON
CHEMICALS, PESTICIDES AND BIOTECHNOLOGY****Cancels & replaces the same document of 3 August 2021****RESOURCE COMPENDIUM OF PRTR RELEASE ESTIMATION
TECHNIQUES PART II: SUMMARY OF TECHNIQUES FOR NON-POINT
(DIFFUSE) SOURCE****Series on Pollutant Release and Transfer Registers
No. 24****JT03479916**

*OECD Environment, Health and Safety Publications
Series on Pollutant Release and Transfer Registers
No. 24*

**RESOURCE COMPENDIUM OF PRTR RELEASE ESTIMATION
TECHNIQUES PART II: SUMMARY OF TECHNIQUES FOR NON-POINT
(DIFFUSE) SOURCE**

IOMC

INTER-ORGANIZATION PROGRAMME FOR THE SOUND MANAGEMENT OF CHEMICALS

A cooperative agreement among FAO, ILO, UNDP, UNEP, UNIDO, UNITAR, WHO, World Bank and OECD

Environment Directorate

ORGANISATION FOR ECONOMIC COOPERATION AND DEVELOPMENT

Paris 2020

About the OECD

The Organisation for Economic Co-operation and Development (OECD) is an intergovernmental organisation in which representatives of 36 industrialised countries in North and South America, Europe and the Asia and Pacific region, as well as the European Commission, meet to co-ordinate and harmonise policies, discuss issues of mutual concern, and work together to respond to international problems. Most of the OECD's work is carried out by more than 200 specialised committees and working groups composed of member country delegates. Observers from several countries with special status at the OECD, and from interested international organisations, attend many of the OECD's workshops and other meetings. Committees and working groups are served by the OECD Secretariat, located in Paris, France, which is organised into directorates and divisions.

The Environment, Health and Safety Division publishes free-of-charge documents in twelve different series: **Testing and Assessment; Good Laboratory Practice and Compliance Monitoring; Pesticides; Biocides; Risk Management; Harmonisation of Regulatory Oversight in Biotechnology; Safety of Novel Foods and Feeds; Chemical Accidents; Pollutant Release and Transfer Registers; Emission Scenario Documents; Safety of Manufactured Nanomaterials; and Adverse Outcome Pathways.** More information about the Environment, Health and Safety Programme and EHS publications is available on the OECD's World Wide Web site (www.oecd.org/chemicalsafety/).

This publication was developed in the IOMC context. The contents do not necessarily reflect the views or stated policies of individual IOMC Participating Organizations.

The Inter-Organisation Programme for the Sound Management of Chemicals (IOMC) was established in 1995 following recommendations made by the 1992 UN Conference on Environment and Development to strengthen co-operation and increase international co-ordination in the field of chemical safety. The Participating Organisations are FAO, ILO, UNDP, UNEP, UNIDO, UNITAR, WHO, World Bank and OECD. The purpose of the IOMC is to promote co-ordination of the policies and activities pursued by the Participating Organisations, jointly or separately, to achieve the sound management of chemicals in relation to human health and the environment.

This publication is available electronically, at no charge.

Also published in the Series on Pollutant Release and Transfer Registers Documents: [link](#)

**For this and many other Environment,
Health and Safety publications, consult the OECD's
World Wide Web site (www.oecd.org/chemicalsafety/)**

or contact:

**OECD Environment Directorate,
Environment, Health and Safety Division
2 rue André-Pascal
75775 Paris Cedex 16
France**

Fax: (33-1) 44 30 61 80

E-mail: ehscont@oecd.org

© OECD 2020

Applications for permission to reproduce or translate all or part of this material should be made to: Head of Publications Service, RIGHTS@oecd.org, OECD, 2 rue André-Pascal, 75775 Paris Cedex 16, France
OECD Environment, Health and Safety Publications

FOREWORD

With more and more countries developing PRTR programmes, it would be time consuming for a country to search for release estimation techniques (RETs) already established in other countries, and resource intensive to develop RETs on its own. The development of RETs can be considered a significant task for countries implementing a PRTR programme.

The OECD began work on the Pollutant Release and Transfer Register (PRTR) RETs project in 1999. That same year, an expert workshop was held to: (1) identify what information is readily available on RETs for point and diffuse sources; and (2) recommend what can be done to improve the use and availability of such techniques (OECD, 1999^[1]). One of the recommendations from the workshop was to establish a Task Force to manage OECD work in this area. The Task Force on PRTRs was established in 2000 under the auspices of the Joint Meeting of the Chemicals Committee and the Working Party on Chemicals, Pesticides and Biotechnology. In 2016, the Task Force was renamed as the Working Group on PRTRs (WG-PRTRs).

The work programme of the WG PRTRs calls for the development and periodic revision of several technical documents to provide governments and industry - as well as others who are interested in this issue - with information and practical guidance for identifying, selecting and applying different techniques for estimating pollutant releases from point and diffuse sources and from transfers. The *Resource Compendium of PRTR RETs* – which includes a number of Parts - is the first in a series of documents created to help accomplish this goal. The intent of this Resource Compendium is to provide OECD countries with a basic information resource on estimation techniques that are used (or are expected to be used) in calculating pollutant releases from point and diffuse sources, transfers and products.

The *Resource Compendium* consists of four separate volumes:

- Part I: Summary of Point Source Techniques, published in 2002 and updated in 2013 [ENV/JM/MONO(2002)20/REV1];
- Part II: Summary of Diffuse Source Techniques, published in 2003 [ENV/JM/MONO(2003)14];
- Part III: Summary of Techniques for Estimating Quantities Transferred, Released or Disposed, published in 2005 and updated in 2017 [ENV/JM/MONO(2017)1]; and
- Part IV: Summary of Techniques for Estimating Releases of Chemicals from Products, published in 2011 and updated in 2017 [ENV/JM/MONO(2017)2], [ENV/JM/MONO(2017)2/ANN].

This document presents a summary of the major RETs used to estimate non-point emissions to air and water, an overview of OECD country programmes and information on relevant contacts and documentation. This document is an updated version of Part II. It was originally published in 2003 and updated to reflect new and additional information.

The aim of this document is not to make specific recommendations on preferred estimation techniques; rather, it is to provide a catalogue of available techniques to estimate releases (emissions) from diffuse (non-point) sources, and to summarise the pertinent information

needed to apply them. Another aim of this project is to provide a listing of reports and other documentation describing the various methods being used in OECD countries to estimate releases of pollutants to air, water, and land from diffuse sources.

This document should be seen as a 'living' document, which provides the most up-to-date information available. It can be updated periodically to include new information. Users of the document are encouraged to submit comments, corrections, updates and new information to the OECD Environment, Health and Safety Division (ehscont@oecd.org). The comments received will be forwarded to the WG-PRTRs, which will review the comments so that the document can be updated accordingly.

This document is published on the responsibility of the Joint Meeting of the Chemicals Committee and the Working Party on Chemicals, Pesticides and Biotechnology of the OECD.

Table of Contents

OECD Environment, Health and Safety Publications	Series on Pollutant Release and Transfer
Registers	No. 24..... 2
RESOURCE COMPENDIUM OF PRTR RELEASE ESTIMATION TECHNIQUES PART II: SUMMARY OF TECHNIQUES FOR NON-POINT (DIFFUSE) SOURCE.....	2
FOREWORD.....	5
ABBREVIATIONS AND ACRONYMS	9
EXECUTIVE SUMMARY	11
1. INTRODUCTION.....	12
1.1. Characteristic of Non-point Source	12
1.2. Methodology	13
2. CHARACTERISTICS OF NON-POINT SOURCE EMISSION INVENTORIES.....	14
2.1. Introduction	14
2.2. Aims and uses of emissions inventories	14
2.3. Definitions	17
2.4. Links between point and non-point source air inventories	20
3. RELEASE ESTIMATION TECHNIQUES FOR NON-POINT SOURCES	22
3.1. Pollutants	22
3.2. Sources	23
3.3. Overview of approaches for air inventories.....	23
3.4. Overview of approaches for non-point source inventories on discharges to water	25
3.5. Accuracy and uncertainty	26
3.6. Quality control and quality assurance.....	27
3.7. Inventory project management	28
4. APPROACHES FOR SELECTED NON-POINT SOURCES	30
4.1. Summary of Techniques used to Estimate Releases from Some Non-Point Sources during Stationary Energy Production	30
4.2. Summary of Techniques for Mobile Sources	46
4.3. Summary of Techniques for Stationary non-combustion	63
4.4. Summary of Techniques for Product Use.....	131
4.5. Summary of Techniques for Agriculture Sources	140
4.6. Summary of Techniques for Land Use and Forestry Sources	152
4.7. Summary of Techniques for Other natural sources	154
4.8. Summary of Techniques for Waste Handling.....	156
4.9. Summary of Techniques for Non-point Discharges to Water	169
5. CONCLUSIONS.....	173
5.1. Build on existing inventory activities	173
5.2. Develop links and share knowledge	173
6. RELEVANT SOURCES OF INFORMATION.....	175
6.1. Air Emissions Inventory Guidance and Emission Factors	175
6.2. Air Emissions Inventory Reports	178
6.3. Non-point Inventories on Discharges to Water	179
6.4. PRTR Reports.....	180
6.5. General References.....	181
References	181

Annex A. KEY CONTACT ORGANISATIONS.....	186
Annex B. INVENTORY SOURCE CATEGORIES.....	187
EMEP/EEA Air Pollutant Emission Inventory Guidebook 2016 (EEA, 2016 ⁽⁹⁾).....	187
Compilation of Air Pollutant Emission Factors, Volume I, Stationary Point and Area Sources, AP-42 (US EPA, 1995-2018).....	188
US EPA EIIP Technical Report Series, Volumes 1-10 (US EPA, 1995-2007).....	189
The Netherlands Emissions Inventory: Non-point sources included for releases to air, water and soil	191
The Australian National Pollutant Inventory: Aggregated emissions sources (Environment Australia, 1999-2003).....	193
EIPCCB (European Integration Pollution Prevention and Control Bureau) Best Available Techniques Reference Documents.....	194
Annex C. EMISSIONS INVENTORIES THAT INCLUDE NON-POINT SOURCES.....	196
C.1. Introduction.....	196
C.2. Transboundary reporting requirements	197
C.3. Regional Activities	201
Annex D. CONVERSION TABLE OF DIFFERENT UNITS.....	208

Tables

Table 3.1. Summary of main criteria air pollutants and their precursors	22
Table 4.1. Summary of categories, techniques and information sources.....	31
Table A C.1. EU ratification status of the LRTAP Convention and related protocols	198

Figures

Figure A C.1. Relationship between inventories, reporting requirements and PRTRs.....	197
Figure A C.2. Relationship between the different surface water compartments and pathways (P1-P13)	206

ABBREVIATIONS AND ACRONYMS

BOD	Biological oxygen demand
CARB	California Air Resources Board
CH ₄	Methane
CITEPA	Centre Interprofessionnel Technique d'Etudes de la Pollution Atmospherique (France)
CLRTAP	Convention on Long Range Transboundary Air Pollution
CO	Carbon Monoxide
CO ₂	Carbon Dioxide
COD	Chemical Oxygen Demand
CORINAIR	European programme to establish Coordinated Inventory of Atmospheric Emissions
CRTK	Community Right-to-know
DEFRA	Department for the Environment, Food and Rural Affairs (UK)
DETR	Department for the Environment, Transport and Regions
EA	Environment Australia
EC	European Commission
EEA	European Environment Agency
EIIP	Emissions Inventory Improvement Program (US)
EIPPCB	European Integrated Pollution Prevention and Control Bureau
EMEP	European Monitoring and Evaluation Programme
EPA	Environmental Protection Agency
EPAV	Environment Protection Authority, Victoria, Australia
EPER	European Pollutant Emission Register
ETC	European Topic Centre
EU	European Union
GIS	Geographic Information System
HAP	Hazardous Air Pollutant
HARP	Harmonisation of Reporting Procedures
HELCOM	Helsinki Convention
HFC	Hydrofluorocarbon
IEA	International Energy Agency
IFEN	Institut Francais de l'Environnement (France)
IPCC	Intergovernmental Panel on Climate Change
IPPC	Integrated Pollution Prevention and Control
LPG	Liquefied Petroleum Gas
LTO	Landing and take-off cycle (for aircraft)
MEDPOL	Convention on Protection of the Mediterranean Sea
N	Nitrogen
NATA	National Air Toxics Assessment (US)
NEI	National Emissions Inventory (US)
NGGIC	National Greenhouse Gas Inventory Committee (Australia)
NH ₃	Ammonia
NMVOG	Non-Methane Volatile Organic Compounds
N ₂ O	Nitrous Oxide
NO	Nitric Oxide
NO ₂	Nitrogen Dioxide
NO _x	Oxides of Nitrogen
NPI	National Pollutant Inventory (Australia)
NPRI	National Pollutant Release Inventory (Canada)
NSW EPA	New South Wales Environment Protection Authority, Australia
NTI	National Toxics Inventory (US)

O ₃	Ozone
OSPARCOM	Oslo and Paris Commission
P	Phosphorous
PAH	Polycyclic Aromatic Hydrocarbon
PFC	Perfluorocarbon
POP	Persistent Organic Pollutant
PRTR	Pollutant Release and Transfer Register
QA	Quality Assurance
QC	Quality Control
REACH	Registration, Evaluation, Authorisation and Restriction of Chemicals
RET	Release Estimation Technique
RVP	Reid Vapour Pressure
SF ₆	Sulphur hexafluoride
SME	Small and Medium Size Enterprises
SNAP	Selected Nomenclature for Sources of Air Pollution (EU)
SO ₂	Sulphur Dioxide
TFEIP	Task Force on Emissions Inventories and Projections
TIM	Time in Mode (for aircraft)
TRI	Toxics Release Inventory (US)
UNFCCC	United Nations Framework Convention on Climate Change
US	United States
VKT	Vehicle Kilometres Travelled
VMT	Vehicle Miles Travelled
VOC	Volatile Organic Compound

EXECUTIVE SUMMARY

Description of the Resource Compendium

The Resource Compendium of PRTR RETs covers estimation techniques to quantify releases from diffuse (non-point) sources. As the documentation and details associated with a specific estimation technique can be lengthy (hundreds of pages for some techniques), the Resource Compendium simply gives information about a technique and the location where more documentation can be found. Further information about techniques used to quantify releases and transfers from sources covered by a PRTR, and their documentation, is available through an Internet based Resource Centre for PRTRs¹.

This Compendium is intended to assist those involved with PRTRs and emission inventories to make decisions and obtain more detailed guidance information. This Compendium is not intended as a standalone guide on release estimations, but rather as a roadmap to help users identify what techniques are being used and where more detailed guidance can be found.

Summary of contents

This Resource Compendium of PRTR RETs defines non-point (diffuse) emission sources and discusses how non-point emission source data are collected, describes the different types of techniques available for various non-point sources and discusses how to identify or calculate the input data for the techniques. One final point raised in this document is that there are many types of non-point release data available (e.g. emissions from mobile sources) that are not compiled by most PRTRs, but are compiled in other types of emission inventories. Most PRTR programmes have yet to integrate such data, or otherwise make it available through their respective PRTRs to complement the emission data that is reported to them.

The Resource Compendium specifically addresses estimation techniques for releases from non-point sources, provides guidance and information on what techniques are available and notes the locations of where this information might be found. While this document is not a comprehensive guide of all techniques available and all source categories, it does provide a wide range of information about techniques currently used in a large number of OECD countries.

¹ http://www.prtr-rc.fi/documents_e.php?switch=all

1. INTRODUCTION

1.1. Characteristic of Non-point Source

As most PRTR systems do not require that quantities of pollutants reported as released from point or non-point (diffuse) sources or transfers be measured, a key aspect of any PRTR programme is to provide guidance to facilities on how such quantities can be estimated. For point sources, facilities or other establishments that report data to a national PRTR may use estimation techniques (e.g. emission factors, mass balance calculations) to characterise quantities of pollutants released and transferred, rather than submitting specific monitoring data. As different industrial processes and activities involve different throughputs, equipment and operating conditions, different methods for estimating releases and transfer quantities are required. Different types of techniques are also used to calculate releases from non-point sources.

Historically, pollutant emission inventories have been developed as tools to assist governments to tackle environmental problems, particularly air pollution, climate change, pollution of inland and marine waters and contaminated soils and, in the case of PRTRs, to inform people of the quantities of pollutants released or otherwise managed as waste in their communities. The scope of many inventories includes not only 'point' (or industrial) sources, but also non-point sources. Point sources are considered to be stationary industrial facilities that generate emissions. Non-point sources can be defined as area sources, mobile sources, biogenic sources and geogenic sources. In many situations, non-point sources can be a major source of emissions. For example, in many urban areas, the primary source of oxides of nitrogen is motor vehicle emissions rather than industrial facilities. For more information on non-point sources of pollutants and why non-point sources should be included in a national PRTR, see UNITAR's Guidance on Estimating Non-point Source Emissions² (UNITAR, 1998_[2]).

The primary difference between PRTRs and other types of emission inventories is that PRTRs are intended to cover all environmental media, whereas the more traditional emission inventories are media-specific (i.e. air or water). In addition, the scope of traditional emission inventories tends to cover a more limited set of pollutant species than PRTRs. In addition, traditional emission inventories, while publicly accessible, are not optimised for use by the public since such inventories are designed for use by federal authorities to serve programmatic needs. PRTRs, on the other hand, are intended for use by the public for informed decision-making, and access to and use of the data contained in PRTRs is designed accordingly.

While PRTRs are national systems, emission inventories vary and can be national or limited in scope to a defined geographic region or to a specific catchment area or airshed. When incorporated into a PRTR, the aggregated data from non-point sources complement point source data by providing context, including information about the relative contributions of various sources and broad spatial patterns.

Increasingly, OECD countries are including release data from non-point sources in their PRTRs. This is to provide a broader picture of the sources of pollutants. PRTR managers wanting to incorporate non-point sources will often be able to incorporate existing inventory data. For example, non-point source components of a greenhouse gas inventory could be incorporated directly, although further work may be needed to disaggregate such

² <http://prtr.unitar.org/site/document/1264>

data spatially. Other emissions inventory data may need to be supplemented, for example, expanding traditional air inventory data to incorporate ‘hazardous air pollutants’ as well as criteria air pollutants.

This Compendium summarises those RETs for non-point sources that are often used or can be used by facilities for their submissions to PRTR or for a specific emission inventory. Specific attention is paid to the manner in which traditional emission inventories overlap with PRTRs, including consideration of the following issues: how the design of a PRTR affects the data that are available in a non-point source emission inventory, the RETs that can be used and the accuracy of the data reported in a non-point source inventory. Interested readers should also consult UNITAR’s Guidance on Estimating Non-point Source Emissions (UNITAR, 1998^[2]). Originally published in 1998, this guidance is currently undergoing revision, and the updated version is scheduled for release in 2020.

1.2. Methodology

1.2.1. Information sources

This Resource Compendium is an update of the Resource Compendium of PRTR Release Estimation Techniques, Part 2: Summary of Diffuse Source Techniques published in 2003. This Resource Compendium contains extracted elements and corresponding descriptions for each non-point source in Part 2 of the 2003 Resource Compendium as well as additional non-point sources. Where possible, the RETs have been updated with the most recent techniques in the Resource Centre for PRTRs. When new information was not found in the Resource Centre, literature/internet searches were performed to see if updated information exists outside the Resource Centre. In addition, Nordic research institutes and authorities provided information on their existing studies and inventories on releases from the use of products. It is possible that other relevant material not identified during the study exists, as a full search of existing RETs was not carried out. Another useful resource on PRTRs is UNITAR’s Collection of International Guidance Materials on PRTRs³ (UNITAR, 2017^[3]).

1.2.2. Structure of the Document

The Resource Compendium provides information of activities by countries and different organisations in their efforts to identify, classify and quantify information and to restrict releases from non-point sources. The document is divided into six chapters and four annexes. Chapter 2 describes the characteristics of traditional emission inventories that incorporate non-point sources. Chapter 3 provides an overview of RETs for non-point sources. Chapter 4 addresses approaches to estimate releases from different emission sources. Chapter 5 discusses conclusions and Chapter 6 provides relevant sources of information.

The first two annexes contain information on how to locate RETs for non-point sources, including key contact organisations for non-point source inventories. The third annex contains an overview of country approaches to specific emissions inventories. The last annex provides a list of unit conversions.

³ <http://prtr.unitar.org/site/document/1270>

2. CHARACTERISTICS OF NON-POINT SOURCE EMISSION INVENTORIES

2.1. Introduction

Before considering specific RETs to quantify releases from non-point sources, it is important to understand the aims and uses of traditional emission inventories, the types of pollutants considered in such inventories and the relationships between point and non-point sources. These factors define the general methodological approaches and RETs used for different source categories in non-point source inventories.

The remainder of this chapter will focus on non-point sources of data in emission inventories and provide working definitions of pollutant sources.

2.2. Aims and uses of emissions inventories

An emission inventory is a comprehensive compilation, by source, of the emissions of specified pollutants to air, water or land, covering a specific geographic area and for a particular period. Inventories vary greatly depending on the purposes for which they are developed according to:

- the number and types of pollutants addressed;
- whether non-point sources are included in addition to point sources;
- the spatial coverage and degree of detail including spatial and temporal resolution;
- the degree and style of transparency and public access to the inventory data;
- the inventory's links with government regulatory processes; and
- whether the inventory data are optimised for use by the public.

PRTRs are a unique type of inventory in that they are rooted in the right of communities to know the quantities of pollutants released or otherwise managed as waste by industrial facilities in their communities. As such, PRTRs are designed to provide easy access to and analysis of such information. Key distinguishing characteristics of PRTRs include: site-specific reporting, periodic reporting (typically annually), a listing of pollutants, coverage of all environmental media (air, water, land) and data on pollutant releases, transfers or other waste management practices (e.g. quantities recycled, burned for energy recovery), and easy access to and analysis of the data. UNITAR's Series of PRTR Technical Support Materials⁴ is an excellent resource to learn more about PRTR design and implementation (UNITAR, 1998_[2]).

Many other types of inventories exist in OECD countries. In general, those that include non-point sources are not integrated across the environmental media but relate to a specific environmental medium (i.e. to air, water or land). While they may be nationally based, many apply to smaller geographic regions and are defined by jurisdictional or administrative boundaries, urban airsheds or catchments.

The driving forces for the development of an inventory that can influence whether or not non-point sources might be included are:

⁴ <http://prtr.unitar.org/site/document/1262>

- **Regulatory:** These inventories generally focus on point source emissions (to single or multiple environmental media depending on the inventory scope) and are frequently integrated with licensing and emissions monitoring systems.
- **Community right-to-know (in regard to PRTR inventories):** These tend to focus on point source emissions to all media and to have longer pollutant lists (i.e. cover a greater number of pollutants) than inventories developed solely for regulatory purposes. While some of these inventories include non-point sources (e.g. the Netherlands Emissions Inventory⁵, the Australian National Pollutant Inventory), the majority tend to focus on point source releases.
- **Government planning, policy development and reporting tools:** These generally include point and non-point sources and may have more restricted pollutant lists than inventories developed for the purposes of community right-to-know. Their focus is generally on known environmental problems and the inventories are used as research tools for informing longer-term policy design, development and evaluation.

Non-point source inventories for air and, to a lesser degree, water, are well established in virtually all OECD countries. In most cases, these inventories are medium-specific and generally attempt to include all significant point and non-point sources. The typical uses of both air pollutant inventories and inventories on discharges to water include:

- monitoring trends in emissions (e.g. against emission reduction targets);
- characterising the nature of environmental burdens and their sources;
- assisting policy development;
- tracking progress of government policy (including regulatory) initiatives;
- as inputs to airshed and catchment modelling in order to assess current and potential future environmental quality;
- as inputs for risk assessment studies;
- assisting policy development, evaluation and reporting for national or international programmes;
- assisting environmental impact assessments in relation to proposed new sources of emissions;
- disseminating information so as to raise public awareness of environmental issues;
- broadening public involvement in environmental policy decision-making processes; and
- helping select sites for locating monitoring equipment.

For all of these applications, having a reasonably complete, technically defensible inventory, with no major sources missing, is paramount. Clearly, the level of detail and accuracy will vary, depending on the intended end uses of the inventory.

⁵ <http://www.emissieregistratie.nl/erpubliek/bumper.en.aspx>

2.2.1. Air emission inventories

Air emission inventories have developed over several decades and methodologies for estimating emissions from non-point sources are well established and documented. The spatial scale and the level of detail of such inventories range from national inventories down to those covering specific urban regions. National inventories (such as greenhouse gas inventories) tend to be used to monitor trends and progress towards emissions reduction strategies, to support national or state policy development, and may be used for broad scale modelling to assess transboundary impacts, such as acid rain.

Inventories established at a regional or local level are also used to assist policy development. However, they differ from national inventories in that they are generally used in combination with air quality modelling and possibly exposure modelling, under different meteorological conditions. These inventories play an important role in the development of air quality management plans for urban regions. This usually involves the projection of emissions into the future and modelling of alternative scenarios to explore likely implications for future air quality. The model outputs can also be used as background concentrations when assessing the impact of proposed new industrial or road developments. Spatially disaggregated emissions data in the form of maps showing gridded emissions are often used to assist land use planning, indicating areas likely to be subject to high levels of pollution. Inventory data can also assist with the design of monitoring networks. When incorporated into a PRTR, the aggregated data from non-point sources complement point source data by providing context, including information about the relative contributions of various sources and broad spatial patterns.

Traditionally, air emission inventories have focused on what are typically referred to as common or criteria pollutants – those for which air quality standards are defined and which are known to have significant health and environmental impacts. Increasingly, however, other pollutants are being included, particularly metals and various organic chemicals. This is being driven by the increasing awareness of the potential adverse impacts of these substances and international reporting requirements. For example, greenhouse gas inventories have evolved in the last decade closely linked to the requirements of UN Framework Convention on Climate Change (UNFCCC). These are generally prepared on a national or sector/activity basis. Often, data are not spatially disaggregated, as the location of emissions sources is not a relevant consideration for climate change impacts. Under another international convention, the UNECE Convention on Long-Range Transboundary Air Pollution (CLRTAP) information on spatial aggregation of emissions is provided. The CLRTAP covers emissions to air of acidifying compounds, particles, metals and persistent organic compounds.

An important characteristic of air emission inventories is that they include extensive underlying data sets, including:

- spatially and temporally resolved data;
- emission factors and activity data used to generate emissions estimates;
- source data collected from industry and other data providers, such as population, vehicle kilometres travelled (VKT), sales information;
- spreadsheets and databases representing various steps in the calculation procedures; and
- spatial data, often part of a computerised geographic information system (GIS).

The aggregated data on total emissions from sectors and individual sources represent the ‘front-end’ of an inventory. It is often the case that this is the only information that is widely disseminated to stakeholders (i.e. the underlying datasets are frequently treated as confidential or are not readily available).

2.2.2. Inventories on discharges to water

Non-point inventories on discharges to water typically involve the estimation of nutrient loads entering inland or marine waters. This reflects the longstanding concern with eutrophication in many parts of the world. The estimation of pollutant export rates (emissions) is often linked with overall attempts to model pollution impacts on receiving waters through the use of catchment runoff models. Other indicators that are not chemical species are usually included in the model, for example, biological oxygen demand, suspended solids and bacteriological agents.

Runoff estimates are often based on generation rates for different land uses and the basic geographic unit (which is frequently the same as the geographic scope of the inventory) is the catchment area for the water body of interest. Nutrients are normally represented by estimates of total nitrogen and phosphorous loads. Increasingly other pollutants, such as metals and organic chemicals, are being addressed, again driven by growing awareness of their impacts and reporting requirements. The atmospheric contribution of some of these pollutants, most notably nitrogen, is often included in the catchment modelling, depending on the proximity of large urban areas or industry. This reflects an important link between air pollutant inventories and inventories on discharges to water.

Catchment models incorporating emission loads are important tools in the catchment area management plans, facilitating the understanding of the impacts of land use and management changes on waterways. Catchment models tend to be designed and calibrated for particular catchment areas or regions and, as a consequence, are less readily transferable than air RETs to other regions or countries. Compared with air emission inventories, the overall accuracy of such inventories tends to be low, reflecting the greater complexity of calculating pollutant export rates and the enormous variability under different climatic conditions and between different catchment areas.

2.2.3. Waste and emissions to soil

Non-point sources of waste or contamination to soil have the potential to cause adverse ecological or public health effects. The placement or disposal of waste that can potentially lead to the contamination of soil are prohibited by law. There are multiple directives in Europe, outlined in detail in European Commission JRC Technical Report on soil threats in Europe, which restrict and control contamination to soil. These directives include creating financial consequences for contaminating soil, controlling industrial activities to intervene at the source of soil contaminants, and implementing technical requirements for waste and landfills (EC, 2015^[4]; Djurhuus et al., 2013^[5]). Non-point sources that result in emissions to soil include the use of products (Section 4.4.2.1), manure management (Section 4.5.1.2), fertilizer use (Section 4.5.1.4), and pesticide use (Section 4.5.1.5). See Section 4.8 for non-point source categories pertaining to waste.

2.3. Definitions

An integral part of any inventory is to establish terminology and associated definitions. There is some difference between the definitions that have been adopted for national

PRTRs and other emission inventories. The following working definitions have been adopted to ensure consistency of OECD's work on RETs.

2.3.1. Point sources

Point sources range from large, stationary, identifiable sources of pollutant releases, such as manufacturing plants, mines, and electric utilities, to small point sources, such as gas stations and dry cleaners. Some countries may group small point sources into the area source category of non-point sources. Within a given point source, there may be several point level releases or stack emissions, as well as fugitive releases (e.g. small leaks, valve releases) that make up the point source. For a better understanding of the distinction between point and nonpoint sources and how emissions from stationary sources are typically reported, see (EC, 2018_[6]).

2.3.2. Non-point source

'Non-point' emissions are assumed to cover all emissions other than those classified as 'point sources' for a particular inventory. As stated above, some countries often include small point sources within non-point sources. In broad terms, non-point sources may, in a specific inventory, cover some or all (depending on the specific scope of the inventory) of the emissions from area, mobile, biogenic and geogenic sources. Large point source emissions are normally, for the purposes of emission inventories and PRTRs, considered of sufficient importance to be included individually.

In addition, the specific definition of a non-point source will, to some extent, depend on the purpose of the inventory and the resulting degree of detail and spatial resolution. A detailed local-scale inventory may measure or estimate emissions from every small industrial plant, meaning that these plants are effectively treated as point sources. On a regional or national level, many of these would fall below any thresholds for point sources and be treated as area sources. However, collectively, the releases from all of these smaller facilities in the area may be significant and, therefore, these sources should be included in the PRTR. Some of the sources covered in Chapter 4 of this document (such as dry cleaners) are actually small point sources, but are normally dealt with collectively for practical reasons. In a local-scale inventory, however, these could be treated as individual point sources, using data from individual premises.

Thresholds for defining which industrial facilities are to be treated as individual point sources in an inventory may be based on:

- the size of a facility;
- the number of employees;
- quantities of listed substances handled or fuel used; and/or
- estimated emissions of listed pollutants.

The level at which thresholds are set will depend on the objectives, including accuracy and resolution, of the PRTR. In general, higher thresholds will minimise the number of point sources. However, the greater the proportion of industrial emissions dealt with in aggregate as non-point sources, the greater will be the loss of accuracy. Spatial accuracy will also be lost if population density or other surrogates are used in place of locations of individual premises. Dealing with sub-threshold combustion emissions from industry, for example, will require assumptions about 'average' boilers and their emissions, and a spatial allocation based on population distribution, industrial employment or industrial land use.

The greater the subthreshold sector becomes in relation to total industry emissions, the more important it is to obtain accurate activity data (such as fuel use) for the study region as a whole.

For the purposes of this document, non-point inventories on discharges to water exclude consideration of releases from obvious point sources such as sewage treatment plants. A storm water outlet is also assumed to be a point source in relation to receiving waters, even though storm water may be generated from runoff (and is therefore captured in a catchment model) and the sources are usually non-industrial. Inventories on discharges to water need to ensure that double counting does not occur, due to the potential multi-stage process between initial pollutant generation and final emissions to a water body.

For the purposes of the OECD work on RETs, the following categories of non-point sources have been agreed to under the adopted working definition for “non-point sources”.

2.3.2.1 Area sources

Area source releases include:

- Releases from small stationary point source facilities whose individual releases do not qualify them as point sources (i.e. do not exceed defined reporting thresholds). For example, as discussed above, a single dry cleaner within a PRTR area typically will not qualify as a point source.
- Releases which result from a large number of very small sources spread relatively uniformly over extensive areas. Examples include residential wood combustion, architectural surface coatings, pesticide use and solvent use.
- Releases from area sources are not compiled using the same methods as emission inventories for point sources. The level of effort required to collect data and estimate emissions from the large number of individual facilities or activities would be very high and often impracticable, especially with respect to the relatively low levels of pollutants emitted by each. To estimate releases from area sources, the individual facilities or activities are grouped with like facilities or activities into broad source categories so that releases can be collectively estimated using one methodology.

2.3.2.2. Mobile sources

Mobile sources include all non-stationary sources, such as automobiles, trucks, aircraft, trains, construction and farm equipment, and others. Generally, release estimates for individual vehicles are not prepared for these sources. Mobile emissions are normally spatially allocated along linear transport routes but in some cases may be spatially allocated like areas sources, for example recreational boating.

2.3.2.3. Biogenic sources

Biogenic emissions are defined as all pollutants emitted from non-anthropogenic, biological sources. Examples include trees, vegetation and microbial activity.

2.3.2.4. Geogenic sources

Geogenic emissions are defined as emissions from natural occurrences, such as gas seep, soil erosion and volcanoes (geogenic sources are also non-anthropogenic).

2.3.2.5. Products

In this context, the word “product” is used to cover different consumer products or articles as well as chemical products that are used outside industrial activities and can generally be purchased from the store shelf. Consumer products are the result of manufacturing and are purchased for consumption by the average consumer. Chemical products in this context refer to e.g. cleaning agents and insulation material. In the European Registration, Evaluation, Authorisation and Restriction of Chemicals (REACH) legislation, an article is defined as an object which during production is given a special shape, surface or design that determines its function to a greater degree than does its chemical composition.

2.3.3. Sources of further information

Europe

- EC (2018), JRC Reference Report on Monitoring of Emissions to Air and Water from IED Installations, (European Commission, European Union, Luxembourg) <https://ec.europa.eu/jrc/en/publication/eur-scientific-and-technical-research-reports/jrc-reference-report-monitoring-emissions-air-and-water-ied-installations-industrial>.

2.4. Links between point and non-point source air inventories

The nature of the data collected from point sources has important implications for the accuracy and completeness of non-point source estimations. This is because contributions from smaller industrial premises and any sub-threshold emissions are generally calculated by a subtraction process using aggregated statistics for the industrial sector as a whole. The most important example of this relates to emissions from fuel combustion where the amount of fuel consumed by point sources is subtracted from the total fuel consumed in a region (normally available from statistical data) and the remaining fuel is then used to estimate emissions from small industrial premises.

The contribution of small and medium size enterprises (SMEs) to emissions from fuel combustion, surface coatings and other solvents in the aggregate can be significant, and the necessary subtractions cannot be performed if the survey only collects point source emissions data. Hence, it is important to ensure that data on fuel combustion and solvent use are obtained from the major reporting premises. As described above, the levels at which reporting thresholds are set will determine the importance of the sub-threshold area source contributions.

Inventories such as PRTRs that are established primarily for community right-to-know purposes typically focus more on large industrial emitters. Therefore, a portion of industrial releases is not accounted for, as there are many facilities that fall below a threshold level (e.g. dry cleaners), and numerous other non-point sources releasing pollutants of concern. If supplementary data are not obtained, it could be difficult to make reliable estimates of the remaining sub-threshold industrial emissions. Additionally, the collection of supplementary data greatly assists quality control checks of data submitted by industry. If the emissions inventory is to be used for airshed modelling (which is often the case), other information will be needed and, when possible, expert advice from air quality modellers should be sought when designing the survey.

In broad terms, surveys of emitters for point source inventories, or registers, tend to be carried out at three generic levels, with varying implications for non-point source estimation and possible inventory end uses:

- Total emissions data for each listed pollutant (plus supplementary details of industry contacts, source reduction, reduction targets etc.). This type of inventory is most likely to be designed for community right-to-know purposes.
- Other process information is included, such as details of fuel combustion, solvent use, and emissions control technology. This allows more scope for quality control checks and greatly assists the estimation of the non-point emissions component of the inventory.
- Detailed spatial and temporal data (such as stack heights, emission velocities, diurnal and seasonal patterns) are requested, in addition to the data from items 1 and 2 above. This is the most detailed type of inventory system and is designed to fulfil modelling requirements. It may also be integrated with a licensing system.

In situations where the first type of inventory exists, separate industry reporting processes will also need to be established in urban areas where comprehensive air inventories are required. One complication with including requests for additional information in point source surveys is the possible need to distinguish between mandatory and voluntary requirements. Emissions data are most likely to be mandatory (e.g. as part of a PRTR or licensing regulations) whereas some of the other data needed for inventory purposes may not be.

3. RELEASE ESTIMATION TECHNIQUES FOR NON-POINT SOURCES

3.1. Pollutants

As discussed in Chapter 2, the majority of the non-point inventories that have been developed have focused on emissions to either air or to water. There are, however, some issues specific to air pollutant emissions or inventories on discharges to water that should be discussed as they could have implications for the use of non-point source data in a PRTR. For example, air inventories designed for modelling and policy analysis generally include primary pollutants that are critical to the formation of secondary pollutants such as ozone. This means that mixtures such as VOCs and PM₁₀ are important to include. It is important to note that it is generally not feasible to estimate formation of secondary pollutants by simply adding together releases of individually listed primary pollutants (e.g. organic chemicals and metals). The following table summarises the main criteria air pollutants and their precursors.

Table 3.1. Summary of main criteria air pollutants and their precursors

Criteria Pollutant	Primary and/or Secondary	Secondary Pollutant Formation Process
Carbon monoxide (CO)	Primary	
Ozone (O ₃)	Secondary	O ₃ is formed as a result of the interaction of VOCs and NO _x (which comprises a mix of NO and NO ₂) in the presence of sunlight (<i>i.e.</i> photochemical reactions).
Particles	Primary and secondary	Secondary particles form as a result of photochemical reactions involving NO _x , SO ₂ and NH ₃ aerosols.
Nitrogen dioxide (NO ₂)	Primary and secondary	Oxidation and photochemical reactions convert NO to NO ₂ .
Sulphur Dioxide (SO ₂)	Primary	

Generally speaking, inventories incorporating non-point sources are likely to have a more restricted list of pollutants than those that focus solely on point sources. The pollutants that may be included in air emissions inventories can be grouped as follows:

- criteria pollutants (e.g. NO_x, PM₁₀, SO₂ as listed in Table 3.1);
- greenhouse gases;
- organic chemicals (e.g. benzene, formaldehyde, dioxins), including a subset known as persistent organic pollutants (POPs);
- inorganic gases (e.g. chlorine), although these are less commonly associated with non-point sources; and
- metals (e.g. lead, nickel, chromium) and their compounds.

The types of pollutants that are included in inventories on discharges to water can be grouped as follows:

- nutrients (total N and total P);
- other inorganic pollutants (e.g. metals);
- organic pollutants (e.g. POPs);
- suspended particles; and

- indicators such as BOD, COD, salinity.

A list of PRTRs containing RETs can be found in the OECD's Resource Centre for PRTRs⁶.

3.2. Sources

The non-point sources included under PRTRs, and particularly in air inventories, are often grouped according to sectors. Some of the more common sources of non-point emissions are provided below:

- fuel combustion;
- fossil fuel distribution;
- solvents/product use;
- agriculture and forestry;
- biogenic/geogenic; and
- mobile sources.

Although different countries have adopted different ways of grouping sources, it is common to separate mobile sources, area sources and biogenic/geogenic sources. Annex B provides lists of the sources and major groupings that have been adopted in the US, the Netherlands, and elsewhere in Europe.

Non-point inventories on discharges to water may not incorporate distinct source categories in the same way as air inventories, although an alternative categorisation could be based on the different land use categories (e.g. agriculture, forest, urban) from which non-point pollution is generated. Estimating pollutant loads in catchment areas may then require further detailed information about activities such as manure treatment.

3.3. Overview of approaches for air inventories

Non-point source inventories rely on 'top-down' techniques rather than direct measurement of emissions from individual sources. Emission factors are likely to be based on measurement programmes conducted within the home country or elsewhere. The activity data used in such inventories are largely the data that are already available from government or other sources. In fact, the RETs used in non-point source inventories evolved according to the types of statistical data normally available within a country. As discussed previously, special surveys can be designed to collect specific activity data. For guidance on survey methods, refer to the following documents:

- Australian NPI EET Handbooks, for example: Aggregated Emissions from Domestic Lawn Mowing, (Environment Australia, 1999), <http://www.npi.gov.au/system/files/resources/775a55ca-2c34-6434-11cc-13d988e40ec7/files/lawnmowingrev2.pdf>. Appendix A discusses domestic surveys.

⁶ <http://www.prtr-rc.fi/>

- US EPA EIIP documents, for example: Guidance for Estimating Lawn and Garden Equipment, Emissions Inventory Improvement Programme, Volume IV, Chapter 3 (US EPA, 1997^[7]).

In addition to the three basic types of information used for estimating releases (emission factors, activity data and spatial surrogates), information about individual sources, such as fuel composition or density, may be required. Where emission controls are applied, decision makers may wish to consider the information found in the US EPA document, Rule Effectiveness and Rule Penetration. Rule effectiveness accounts for sources that do not achieve required emissions reductions for various reasons. Rule penetration relates to the proportion of the source category covered by a regulation. For example, vapour recovery for service stations may only apply to geographic sub-regions, stations above a certain size or those built after a certain date. Emissions from certain mobile sources that cross international boundaries (e.g. aircraft) may be excluded from inventories prepared for national reporting purposes but should be included for completeness when considering the total environmental impact within a country or region.

The most common generic approaches relevant to non-point source air inventories are:

- emission factors (based on test data or surveys of manufacturers);
- materials balance (e.g. assumes that all solvent in a product evaporates);
- fuel analysis (e.g. assumes complete conversion of S to SO₂ during combustion); and
- emission estimation models (empirically derived sets of equations to estimate emissions, e.g. MOVES, COPERT 5).

In the absence of specific emission factors, speciation profiles may be needed to speciate VOCs into organic compounds and particles into metals and their compounds. The United States Environmental Protection Agency maintains the SPECIATE Database, a repository of volatile organic gas and particulate matter (PM) speciation profiles of air pollution sources⁷.

The following types of activity data are generally used for area sources:

- population data only (used with default per capita emission factors);
- extrapolated point source data (for SMEs);
- sales, consumption and employment data. These may relate to the specific study area or may have to be scaled down from national or state data and are generally obtained from relevant government agencies or private sector organisations; and
- survey data (e.g. households, small businesses or local governments).

Mobile source emissions estimation generally requires more complex information about vehicle characteristics, fuels used and movements of the fleet of motor vehicles, aircraft or ships. Activity data should relate to the particular study region. Releases from less significant sources, such as construction machinery and household lawn mowers, are often estimated using simpler approaches based on statistical data and emission factors.

For estimating biogenic emissions, complex computer models are used such as BEIS3.61 that require local data on vegetation types. Although biogenic sources are unlikely to be

⁷ <https://www.epa.gov/air-emissions-modeling/speciate>

considered in emission reduction programmes, they are often a significant source of VOCs and so contribute to ozone formation. Airshed modelling needs to take these sources into account in order to simulate atmospheric processes. Geogenic sources, such as sea salt and windblown dust, are difficult to estimate and are often excluded from inventories.

The use of a PRTR will ultimately determine the spatial resolution. The spatial resolution for non-point source air inventories ranges from 500 metres to around 20 kilometres, depending on the size of the country, population size and density, and the use of the inventory. Some inventories, like greenhouse gases, may not be spatially resolved below the national level. Airshed modelling normally requires gridded data across a rectangular domain.

Stationary (non-point) sources in air inventories are usually spatially allocated according to population, but other approaches include:

- locating small ‘point source’ emissions, such as from service stations and dry cleaners, to grid squares according to the actual locations of these facilities (but emissions from each may be assumed to be identical);
- using employment data; and
- using other spatial surrogates (e.g. industrial zones for area-based industrial emissions, agricultural zones/areas).

Mobile sources are generally spatially allocated as line sources based on transport routes. In detailed inventories, this could involve spatially resolving motor vehicle emissions down to individual roads.

Temporal resolution, necessary for modelling purposes, may be defined on different time scales, for instance diurnal, weekly or seasonal. These profiles reflect daily patterns in motor vehicle traffic, fuel combustion etc., weekday versus weekend differences and seasonal differences. In situations where special surveys are conducted, it is possible to collect relevant temporal data, for example times of the day and year when solid fuel combustion or lawn mowing occurs. In many cases, however, assumptions will have to be made to supplement survey and other data.

3.4. Overview of approaches for non-point source inventories on discharges to water

RETs for non-point discharges to water are generally incorporated into catchment models. One way of categorising these models (NSW EPA, 1999^[8]) is as follows:

- empirical;
- conceptual; and
- physics-based.

These groupings are discussed in more detail in Chapter 4, Section 9. Most models require spatial data on land use coverage, as well as other data such as population density, amount of fertiliser used and livestock numbers. Emission factors should relate to specific activities, not just the land use category. Emission factors are applied to specific processes and the calculated emissions from these various sources are aggregated. There is little value in using complex physics-based models if the required input data are not available. The direct sampling of pollutants released from point sources such as storm-water drains may assist in the estimation of pollutant loads from various non-point sources. In addition,

validation of models through measurement of pollutant concentrations in water bodies is important.

3.5. Accuracy and uncertainty

There are many factors that influence the quality of an inventory. The main indicators of data quality are:

- accuracy (the measure of ‘truth’ of a measure or estimate);
- comparability (between different methods or datasets);
- completeness (the proportion of all emissions sources that are covered by the inventory); and
- representativeness (in relation to the study region and sources of emissions).

Key data features such as accuracy, precision, confidence and reliability come into play when addressing issues associated with uncertainty in emission estimates. Accuracy is the degree of agreement between the true value and the data used to represent the value. Determinant or constant errors affect the accuracy of data. Precision is a measure of the agreement among the values in a group of data. As indicated in European Monitoring and Evaluation Programme (EMEP)/ (European Environment Agency) EEA Guidebook, Part A (EEA, 2016^[9]), the term accuracy is often used to describe data quality objectives for inventory data. However, accuracy is difficult to establish in inventory development efforts, since the ‘truth’ for any specific emission rate or emissions magnitude is rarely known. This is the crux of the release estimation process.

Emissions can nevertheless be estimated with both confidence and reliability. Confidence can be defined as the term used to represent trust in a measurement or estimate (EEA, 2016^[9]). Having confidence in inventory estimates does not make those estimates accurate or precise, but will help to develop a consensus that the data can be incorporated into the inventory. Since reliability is defined as ‘trustworthiness, authenticity or consistency’, the use of reliable estimates in an inventory will provide confidence in the data and RETs used in the inventory.

Apart from calculation errors by the team preparing the inventory (which should be minimised by quality control (QC)), sources of error or uncertainty often cannot be quantified. The sources of error or uncertainty include:

- Emission factors that do not reflect real life conditions. The use of emissions factors generally cannot be avoided for practical reasons. Those developed from rigorous local testing are likely to be superior to international ‘default’ emission factors. However, the latter may be acceptable if the source characteristics and operating conditions are much the same as in the country where the tests were done. The accuracy of emission factors is also strongly influenced by the number of tests carried out. Rating systems to reflect the accuracy of emission factors have been developed by the US EPA and also applied in Europe. Factors are rated from A to E, where A is the highest and E the lowest. A describes an emissions factor based on a large number of measurements at a large number of facilities that fully represent the sector.
- Activity data that do not adequately reflect the study region. Scaling down national or state activity data to smaller regions according to population or other indicators will always result in decreased accuracy. The errors are likely to be greatest if the

study region is relatively small and has distinctly different characteristics compared with the region to which the data applies.

- Spatial and temporal disaggregation introduces errors in these dimensions that are difficult to quantify. These errors, however, will depend on the nature of the source and activity data used. For example, while spatial disaggregation based on population may be very acceptable for consumer use of paints, use of sales data may lead to large errors if sales information is not correlated with usage within the study region.
- Sample surveys will be subject to sampling error (which can be quantified) but also to other unknown errors resulting from the accuracy of the reported information and non-responses.

Despite these uncertainties and limitations on accuracy, inventories can be useful tools, provided that they are used for the purposes for which they are designed. Users need to ensure that inventory data are not used for other purposes, such as trying to draw precise conclusions about exposure to pollutants at the local level. Inventories are often of greater value in determining trends rather than absolute values, providing that methodologies are consistent over time or that past inventories are recalculated or updated as necessary to account for changes in inventory methodology.

In general terms, inventories of criteria and greenhouse gas pollutants (excluding biogenic sources) are likely to be the most accurate. The reason is that these pollutants have been studied in the detail and have been the subject of extensive regulatory attention, at both the domestic and international levels. The following inventory types or segments are generally less accurate:

- particles in air inventories from non-combustion sources;
- HAPs based on speciation profiles;
- most biogenic sources; and
- non-point inventories on discharges to water.

3.6. Quality control and quality assurance

Quality control (QC) involves routine technical procedures adopted within the inventory team to measure and control inventory quality. Possible QC procedures include:

- technical reviews of sources of data;
- accuracy checks of data entry and calculations by other team members;
- reality checks against previous inventories or those from other regions;
- computerised checks for data entry errors and reality checks;
- designing and implementing standardised procedures to facilitate checking and tracking of errors;
- statistical checks (e.g. using descriptive statistics, identifying outliers, comparability checks);
- visualisation checks for spatial data (e.g. ensuring land-based sources are not located offshore); and

- using an alternative method to estimate releases, if data are available and resources permit it.

Quality assurance (QA) involves external review and audit procedures conducted by people outside the inventory team. These are usually performed by technical experts in the relevant fields.

The inventory project team will need to develop QA/QC procedures early in the inventory process. The importance of proper documentation needs to be stressed. This greatly assists QA/QC by making it easier to find errors and identify any assumptions. Documentation also ensures reproducibility, transparency to stakeholders (including technical reviewers and other users of the inventory) and assists future inventory updates. Documentation should include all raw data used, assumptions, and all steps in calculations, and communications with data providers and QA/QC processes. Important missing data (e.g. missing pollutants due to a lack of emission factors, missing source types) need to be acknowledged and documented. Sensitivity analyses can also provide a useful insight into inventory quality.

If an inventory is being used for catchment or airshed modelling, a valuable reality check on the inventory as a whole (including point sources) can be made through comparing model outputs with monitoring data. This is the only way of actually knowing whether the inventory (in combination with the model) reasonably reflects the real world situation. In a similar way, measurements of pollutant concentrations in water bodies will indicate the extent to which a water inventory/catchment model system reflects actual emissions or the real world.

3.7. Inventory project management

Depending on the size and extent of the inventory, its preparation will require a team of experts. At least some team members should have inventory experience or, as a minimum, easy access to those experts who would have the time to provide assistance. All team members should have good computer (particularly spreadsheet and GIS) skills, be able to handle large volumes of data easily and be reasonably accurate with good attention to detail. Also helpful would be a basic knowledge of chemistry.

The project manager needs to be a good organiser, have a flexible approach, be a strategic and lateral thinker and have good personal skills. The latter may be needed when dealing with data providers, and is essential in building and managing a successful team. Inventory planning is critical. In particular, relevant reports documenting RETs must be reviewed and sources of activity and spatial data must be identified. Scheduling needs to ensure all data collection commences early in the process and to ensure that sufficient time is allowed for these data to be received. Requests to one agency for different data sets need to be coordinated. In many countries, statistical agencies may keep confidential data disaggregated so as not to compromise their sources. This means time may be needed to establish working relationships and mutual trust. Time should be allocated for staff training, particularly if specialised computer packages are being used.

For further information about inventory project management, refer to the US EPA (1999^[10]) Handbook for Criteria Pollutant Inventory Development⁸. This is designed for state and local agency personnel undertaking air inventories for criteria pollutants from stationary

⁸ <https://nepis.epa.gov/Exe/ZyPURL.cgi?Dockey=P1000MVP.TXT>

sources. Also refer to US EPA's Air Emissions Inventory Improvement Program (EIIP) documents⁹ and the EMEP/EEA guidebook (EEA, 2016^[9]) which also has a useful introduction. The EIIP documents provide standard procedures for developing emission inventories that have targeted quality objectives, are cost-effective, and contain reliable and accessible data for end users.

⁹ <https://www.epa.gov/air-emissions-inventories/air-emissions-inventory-improvement-program-eiip>

4. APPROACHES FOR SELECTED NON-POINT SOURCES

This chapter presents a selection of techniques for estimating releases from those non-point source categories that are likely to be among the most significant sources of pollutants in OECD countries. The list of categories is by no means intended to be complete; (other sources are documented in the various emission inventory guidebooks listed in the bibliography and, in some countries or regions, there are bound to be other sources as well). The sources covered here do, however, illustrate the generic estimation approaches in common use. The selection of sources and emission estimation techniques will definitely depend on the objectives of the inventory, its resolution, the nature of the study area and the pollutants to be included. These characteristics would generally be resolved early in the process (see Chapter 3), prior to finalising estimation methodology.

While this chapter presents a selection of RETs for particular non-point sources, Annex B lists all non-point source categories covered in the main guidebooks and software available from the US EPA and the EEA (US EPA, 1995^[11]; US EPA, 1985^[12]; EEA, 2016^[9]; EC, 2018^[6]) for air emission inventories as well as in the Dutch Emissions Inventory and the Australian NPI. Depending on the degree of detail required in the inventory and reporting thresholds set for point sources, additional sources not discussed here (but covered in the available guidebooks) may need to be inventoried as non-point sources.

Methodologies for estimating greenhouse gas releases are not specifically included, although greenhouse gas sources frequently coincide with urban air pollutant sources. Greenhouse gas inventory techniques are well documented by the Inter-governmental Panel on Climate Change (IPCC, 2006^[13]). The RETs considered in this document are generally consistent with or are more detailed than the IPCC default methods. The EMEP/EEA Guidebook has been specifically designed to suit reporting of air pollutant emissions while the IPCC guidelines for greenhouse gases encourage consistency in approaches and input data. That is, if greenhouse gases are included in a PRTR, data acquisition processes should be minimised and consistency maximised. Biogenic and geogenic sources are not covered.

4.1. Summary of Techniques used to Estimate Releases from Some Non-Point Sources during Stationary Energy Production

The first 10 source categories relate to emissions to air. Non-point discharges to water are dealt with in a single section at the end, as methodologies are less distinctive for specific sources. The specific source categories considered here are as follows.

Stationary combustion (see Section 4.1.1)	gas combustion domestic solid fuel combustion liquid fuels combustion
Fuel distribution (see Section 4.1.3)	gasoline distribution natural gas distribution
Mobile sources (see Section 4.2.1)	road traffic aircrafts ships garden maintenance
Stationary Non-combustion (see Section 4.3)	mineral products chemical industry metal production
Solvents containing products (see Section 4.4.1)	industrial solvent-containing products architectural and surface coatings domestic and commercial solvent-containing products
Agriculture (see Section 4.5.1)	enteric fermentation manure management field burning of agricultural waste use of fertilizers use of pesticides agriculture other
Forestry (see Section 4.6.1)	wildfires, prescribed
Other natural sources (see Section 4.7)	
Summary of techniques for waste handling (see Section 4.8)	
Non-point discharges to water (see Section 4.9.1)	catchment runoff

Table 4.1 summarises source categories, techniques and indicates the specific information source on the technique.

Table 4.1. Summary of categories, techniques and information sources

Source category	Estimation method	Sources of information on techniques
Gas combustion	Use of local fuel consumption data	USEPA – EIIP; Australia – NPI EET manuals; EMEP/EEA Guidebook
	Scaling down national or state fuel consumption data	USEPA – EIIP; Australia – NPI EET manuals; EMEP/EEA Guidebook
Domestic solid fuel combustion	Survey to obtain local fuel consumption data	Australia – NPI EET manual; USEPA – EIIP
	Scaling down national or state fuel consumption data	USEPA – EIIP; EMEP/EEA Guidebook
Liquid fuels consumption		USEPA – AP-42; Australia – NPI EET manual; EMEP/EEA Guidebook
Stationary non-combustion (fugitive emissions)		IPCC – 2006 Guidelines; EMEP/EEA Guidebook
Gasoline distribution	Use of gasoline sales information for the region	USEPA – EIIP; Australia – NPI EET manual; EMEP/EEA Guidebook
	Scaling down national or state fuel sales data	USEPA – EIIP; EMEP/EEA Guidebook
Natural gas distribution	Dividing pipelines into sub-categories	IPCC – 2006 Guidelines; EMEP/EEA Guidebook; USEPA – EIIP
	Using total gas sales and average emission factors	IPCC – 2006 Guidelines; EMEP/EEA Guidebook; USEPA – EIIP
Road traffic	Spatially disaggregated VKT/VMT-based methods, often involving the use of specialised software (MOVES, COPERT)	USEPA – AP-42; USEPA – Procedures for Emission Inventory Preparation, Volume IV; EMEP/EEA Guidebook

Source category	Estimation method	Sources of information on techniques
	'Top down' approach based on aggregated fuel consumption data, often used for greenhouse gases	IPCC – 2006 Guidelines; EMEP/EEA Guidebook; Australia – NPI EET manual
	Direct on-road sampling of emissions (rarely used in inventories)	EPA Victoria (1999); NERI (2000)
Aircraft	Spatially disaggregated approach based on LTO cycles for each aircraft type and different operating modes	EMEP/EEA Guidebook; USEPA – Procedures for Emission Inventory Preparation, Volume IV; Australia – NPI EET manual
	Use of default emission factors for different types of aircraft based on national statistics	EMEP/EEA Guidebook; USEPA – Procedures for Emission Inventory Preparation, Volume IV; Australia – NPI EET manual
	Use of default emission factors for an average aircraft, total LTOs and fuel data (CO ₂ only)	EMEP/EEA Guidebook
Ships	Spatially disaggregated approach based on times in berth and channels for ships of different sizes	Australia – NPI EET manual
	Use fuel consumption data for different ship categories	EMEP/EEA Guidebook
	Use of default emission factors and fuel consumption data (CO ₂ only)	EMEP/EEA Guidebook
Garden maintenance	Survey to obtain local data	USEPA – EIIP; Australia – NPI EET manual
	Scaling down national or state fuel consumption data	USEPA – EIIP; Australia – NPI EET manual; EMEP/EEA Guidebook
Industrial solvents	Survey of solvent users	USEPA – EIIP; EMEP/EEA Guidebook
	Use of sales data from suppliers	Australia – NPI EET manual; EMEP/EEA Guidebook
	Use of default emission factors	USEPA – EIIP; Australia – NPI EET manual; EMEP/EEA Guidebook
Architectural surface coatings	Survey of distributors/manufacturers	USEPA – EIIP
	Scaling down national or state consumption data	USEPA – EIIP; Australia – NPI EET manual; EMEP/EEA Guidebook
	Use of default per capita emission factors	USEPA – AP-42
Domestic and commercial solvents	Survey of distributors/retailers or use of consumption data	Method is not normally used and exemption data is rarely available – exception is the Netherlands.
	Use of default per capita emission factors	USEPA – EIIP; EMEP/EEA Guidebook; Australia – NPI EET manual
Other products		OECD Resource Compendium on PRTR RETs for Products
Enteric Fermentation		IPCC – 2006 Guidelines; USEPA – AP-42; USEPA – EIIP; EMEP/EEA Guidebook
Manure management	Process-based model of nitrogen flows	EMEP/EEA Guidebook; USEPA – EIIP
	Use of default emission factors for each animal type	EMEP/EEA Guidebook; IPCC – 2006 Guidelines
Field burning of agricultural waste	Categorisation of farmland according to crop types and use of specific emission factors	EMEP/EEA Guidebook; Australia – NPI EET manual; IPCC – 2006 Guidelines; USEPA – EIIP; USEPA – AP-42
	Use of default emission factors (e.g. amount of waste/fuel per hectare of farmland or forest burnt)	EMEP/EEA Guidebook; Australia – NPI EET manual
Use of fertilizers		IPCC – 2006 Guidelines; EMEP/EEA Guidebook
Use of pesticides		EMEP/EEA Guidebook
Agriculture Other		EMEP/EEA Guidebook; EEA – European Union Emission Inventory Report

Source category	Estimation method	Sources of information on techniques
Wildfires, prescribed	Use of local data to calculate mass of carbon emitted from forest burning	EMEP/EEA Guidebook; IPCC – 2006 Guidelines
	Use of default emission factors (e.g. amount of waste/fuel per hectare of farmland or forest burnt)	EMEP/EEA Guidebook; Australia – NPI EET manual
Other natural sources		EMEP/EEA Guidebook
Summary of techniques for waste handling		EMEP/EEA Guidebook; EEA – European Union Emission Inventory Report; EEA – European Environment State and Outlook; IPCC – 2006 guidelines
Catchment runoff	Load estimation using real data (involves applying various averaging, ratio, and regression methods)	Australia – NPI EET manual; EEA – European Inventory of Emissions to Inland Waters
	Load estimation using catchment modelling (Empirical, Conceptual, Physics-based models)	Australia – NPI EET manual; NSW EPA – Comparison of Selected Models to Estimate Nutrient Loadings; USEPA – Basins 4.1 Model

Source: (EEA, 2016^[9]), (Environment Australia, 1999^[14]), (EPAV, 1999^[15]), (IPCC, 2006^[13]), (NERI, 2000^[16]), (OECD, 2017^[17]), (US EPA, 1985^[18]), (US EPA, 1992^[19]), (US EPA, 1999^[20]).

4.1.1. Stationary combustion

Two specific categories of fuel combustion, natural gas and domestic solid fuel, have been selected as they are the more common fuel combustion categories.

4.1.1.1. Natural Gas combustion

4.1.1.1.1. Nature of the source and relevant pollutants

The pollutants emitted from natural gas combustion include CO, CO₂, NO_x, particulate matter (PM), SO₂, CH₄, N₂O, plus various organic HAPs and metals and their compounds. Natural gas and other fuels, such as LPG, are potentially used in several sectors, in particular the residential, commercial and industrial sectors.

4.1.1.1.2. Factors affecting releases

The specific emissions are strongly dependent on the type of fuel burnt and on the nature of the combustion device. The temperature and the efficiency of combustion are also important, and are implicitly accounted for in emission factors for different units.

Natural gas combustion, particularly in larger industrial and commercial boilers, may be subject to emission controls. The most common controls are flue gas recirculation and low NO_x burners. Depending on the specific source, emission factors may be defined separately according to the control technology in use.

4.1.1.1.3. Description of release estimation techniques

Sources of emission factors

US emission factors for a range of boilers of different sizes and with different control technologies are provided in AP-42 Volume I. These are expressed in terms of mass per unit of volume (pounds per standard cubic feet). European emission factors are also available in the section on ‘Combustion Plants as Area Sources’ in Chapter 1 of the EMEP/EEA Guidebook. These are expressed in terms of mass per unit of energy (g/PJ).

Additional speciation data for some pollutants are available from (CARB, 1991^[21]; CARB, 1991^[22]) and the US EPA's SPECIATE database¹⁰.

Activity data

Activity data used must match the chosen emission factors. In some cases, additional fuel data are needed to apply the emission factor (e.g. to convert mass to volume or to energy output). The two general approaches for compiling activity data are (a) using local data specific to the region, and (b) scaling down data from a larger region.

The preferred approach is to obtain data on the consumption of the relevant fuel types for each sector (domestic, commercial, and industrial) for the specific geographic region of interest. These data should be obtained from all relevant distributors. Accuracy may be reduced if all fuel sold is not consumed in the region or if all distributors are not identified and covered. If data cannot be obtained from a particular distributor, then data from others may need to be averaged and factored up based on population or some other indicator. It should be noted that data on fuel used by individual consumers will normally be confidential and, hence, unavailable from distributors.

To estimate emissions from the industrial sector, additional information should be obtained through any surveys being conducted of major industrial (point) sources. It is important that a survey of these individual facilities obtains information on fuel consumption so that the total fuel consumed by these facilities can be subtracted from the total consumed by industry overall. The remainder will represent fuel consumed by small industry below any reporting threshold for point sources. If this subtraction is not done, double counting will occur.

If local consumption data cannot be obtained, a less accurate method involves scaling down national or state data. Inaccuracies may be introduced depending on differences between the study region and the larger region to which the data apply. Consumption data would normally be available for residential, commercial and industrial sectors. If the gas network is spread across a state or country however, the scaling down approach may be quite acceptable. The approach used in The Netherlands is to use GIS data to distinguish between areas where there are higher proportions of detached dwellings compared with apartments.

When scaling down industrial fuel consumption data, it is generally preferable to use employment rather than population data.

4.1.1.1.4. Spatial allocation

Domestic and commercial emissions from natural gas combustion would normally be allocated by assuming that fuel consumption is directly related to population distribution. If the activity data are available in smaller geographic units (e.g. by postal code), then the emissions could be allocated accordingly. The availability of reticulated gas across the study region should be considered, so that spatial allocation of emissions is restricted to relevant areas.

For industrial emissions dealt with as an area-based source (i.e. excluding individual point sources), emissions could be spatially allocated within industrial zones or according to industrial employment data.

¹⁰ <https://www.epa.gov/air-emissions-modeling/speciate>

4.1.1.1.5. Summary of steps in the process:

1. Identify the relevant fuels for the study region and possible boundaries for gas reticulation.
2. Ensure that a complementary point source survey of individual sites requests the necessary information on fuel combustion.
3. Review and select the most appropriate emission factors, locate and check availability of activity data and obtain any additional fuel parameters that may be needed.
4. Scale down any activity data if necessary.
5. Calculate total emissions for each type of fuel (if more than one) and for each sector. Obtain the industrial contribution by subtracting the total fuel combusted by major point sources from the total fuel used by industry as a whole.
6. Spatially and temporally disaggregate as required.

4.1.1.1.6. Comments on reliability

Consumption data provided by distributors should be reliable, particularly if overall consumption rates relate closely to those in the defined study region. Scaling down from a larger area will reduce accuracy.

Using emission factors from other countries may be less accurate than in the home country, depending on the characteristics of boilers, appliances and fuels. Speciation profiles are relatively less reliable than emission factors.

If fuel consumption data are not collected as part of a survey of major industrial facilities (i.e. those that are treated as point sources in the inventory), and/or total consumption data for industry as a whole are not available, then estimates of emissions from smaller industry are likely to be highly inaccurate. Combustion emissions depend very much on the size and nature of the manufacturing process, types of boilers and control technology. Without data on individual sites, it would be necessary to make gross assumptions for larger industrial facilities as a whole across a study region.

4.1.1.1.7. Sources of further information

Australia

- Environment Australia (1999), Emissions Estimation Technique Manual for Aggregated Emissions from Fuel Combustion (Sub-threshold) (Environment Australia, Canberra, Australia).
<http://www.npi.gov.au/system/files/resources/e097577e-4439-6fb4-fd8f-2bcfaf9c8077/files/subcombustionff.pdf>.
- Environment Australia (1999), Emissions Estimation Technique Manual for Aggregated Emissions from Domestic Gaseous Fuel Burning (Environment Australia, Canberra, Australia).
<http://www.npi.gov.au/system/files/resources/a9a62e48-af10-b004-9502-628d44e01ba0/files/gasburningff.pdf>.

Europe

- EEA (2016), EMEP/EEA Air Pollutant Emission Inventory Guidebook (European Environment Agency, Copenhagen, Denmark), 2016 Edition. <http://www.eea.europa.eu/publications/emep-eea-guidebook-2016>.
- EC (2011), Methodology development for the spatial distribution of the diffuse emissions in Europe, (European Commission, European Union, Luxembourg) https://www.eea.europa.eu/data-and-maps/data/european-pollutant-release-and-transfer-register-e-prtr-regulation-art-8-diffuse-air-data/methodology-report/diffuse_releases_e-prtr_methodology_2011_en.pdf.

US

- US EPA (1995-2018), Compilation of Air Pollutant Emission Factors, Volume I: Stationary Point and Area Sources, AP-42 (United States Environmental Protection Agency, North Carolina, US), 5th edition. <https://www.epa.gov/air-emissions-factors-and-quantification/ap-42-compilation-air-emissions-factors>.
- US EPA (1999), Residential and Commercial/Institutional Natural Gas and LPG Combustion, Area Source Method Abstract from Volume III of EIIP Document Series, (United States Environmental Protection Agency, North Carolina, US). <https://www.epa.gov/sites/production/files/2015-08/documents/ng.pdf>.

4.1.1.2. Domestic solid fuel combustion

4.1.1.2.1. Nature of the source and relevant pollutants

In some countries, the emissions resulting from residential solid fuel (most commonly, wood and coal) burning are a major source of air pollution. A range of combustion devices may be used, including open fireplaces (either masonry or factory-built metal units), conventional wood stoves with no emissions control technology, and stoves incorporating emission controls. Wood stoves may also include catalysts to enhance the combustion process. The pollutants emitted from solid fuel combustion include particulate matter, CO, CO₂, NO_x, VOCs, SO_x, N₂O, CH₄, PAHs and various metallic compounds and organic HAPs.

4.1.1.2.2. Factors affecting releases

The quantity and type of emissions from solid fuel combustion vary greatly, depending on the nature of the device used, the control technology, the type and moisture content of the fuel, the mode of operation by the user and the degradation of the stove. Emissions also vary with the stage of the combustion cycle. In general, higher emissions are associated with slow burn rates and low flame intensity.

Open fireplaces are a particularly inefficient form of heating, with a high proportion of combustion heat being lost.

4.1.1.2.3. Description of release estimation techniques

Sources of emission factors

US emission factors, expressed in pounds per short ton, are available in AP-42 Volume I for the criteria pollutants, a number of individual PAHs, plus a range of organic HAPs and metals. It also includes an N₂O emission factor for fireplaces. The relevant sections are 1.9 (Residential Fireplaces), 1.10 (Residential Wood Stoves) for wood combustion, and 1.1

(Bituminous and Sub-bituminous Coal Combustion), 1.2 (Anthracite Coal Combustion) and 1.7 (Lignite Combustion) for other forms of solid fuel.

Some European emission factors for wood, briquettes and lignite are also available in the section on 'Combustion Plants as Area Sources' in Chapter 1 of the EMEP/EEA Guidebook. These are expressed in terms of mass per unit of energy (g/GJ) and apply to CO, CH₄, VOC and NO_x. Additional emission factors apply to metals from coal combustion.

The Canadian manual provides emission factors for the criteria pollutants, some of which are locally derived. The Australian NPI handbook on domestic solid fuel burning uses a combination of US EPA, CARB and local emission factors applicable to domestic wood and coal combustion.

Activity data

The preferred approach, particularly for wood combustion, is to conduct a sample survey of domestic premises. This is particularly the case in areas where a significant proportion of households are likely to collect their own wood (hence, sales data would provide an underestimate) and data on the relative proportions of different combustion devices is required. The survey approach is most likely to be cost-effective if wood combustion is a significant source of emissions and/or a survey can be justified to gather data on other emission sources as well. The survey needs to collect data on the amount and type of fuel burnt (hardwood or softwood), the type of combustion device used and control technology applied. Respondents may be unaware of emission controls, so it can be more useful to ask when the appliance was purchased, assuming emission control regulations were introduced at certain dates. Seasonal and diurnal variability data should also be sought, particularly if the inventory is to be used for modelling.

Data from sampled households are scaled up according to total study region household numbers. If significant differences in usage within a study region are expected, partitioning the survey into separate sub-regions may be justified. If the extent of wood consumption is strongly related to other factors, such as the age of residence, then these could be incorporated in the survey design. For further information on conducting surveys, refer to the EIIP report on residential wood combustion¹¹. A survey could be carried out either by mail or by telephone.

A mail survey approach to conducting household surveys was developed and refined during trials of Australia's NPI. This generated response rates of 50-55% in a number of different study regions. Guidelines for conducting domestic surveys are included in Appendix A of the relevant NPI Manual.

Expert statistical and survey design advice should always be sought prior to conducting surveys. The following issues must be considered in order to ensure an adequate response rate and to ensure that reliable data are obtained:

- careful design of the layout and wording of questionnaires to facilitate data entry and avoid ambiguity; ask questions that people can reasonably be expected to answer, and formulate them so as to obtain only data that will be used;
- wording used in cover letters, introductory comments and general manner for telephone or door-to-door surveys;

¹¹ https://www.epa.gov/sites/production/files/2015-08/documents/iii02_apr2001.pdf

- sample size;
- pilot surveys;
- follow-up approaches to increase response rates; and
- quality control procedures.

Scaling down national or state consumption data. A simpler approach is to scale down available statistics on the amount of wood and other forms of solid fuel consumed. If the study region is representative of the region to which the data apply, and the self-collection of firewood is insignificant, then aggregated consumption data based on sales may be quite accurate. Data would also be required on the different types of heating devices used. If data are not available, assumptions on the proportions of sales of heating devices would have to be made.

Whichever approach is used to collect activity data, if solid fuel is reported in terms of volume, then additional information will be needed to convert this to weight or energy units, depending on the emission factors chosen.

A top-down approach for coal or lignite combustion is likely to be acceptable providing consumption data are available from government or local distributors. It may be necessary to exclude coal used in commercial and small industrial premises (which could be inventoried as a separate source category) and to subtract the contribution from point sources if activity data cover all users. Note also that household consumption data may include fuel used in barbecues. This may also be significant enough to consider as a separate source.

4.1.1.2.4. Spatial allocation

Emissions would normally be spatially allocated according to household or population distribution. If the survey has been partitioned into sub-regions, then survey data will need to be scaled up and spatially allocated in each sub-region separately. If other spatial factors are defined through a survey process, such as age of residence, then these could be used.

4.1.1.2.5. Summary of steps in the process

1. In the study region, establish the significance (or otherwise) of domestic solid fuel combustion as a source of emissions and indicate the relevant fuels.
2. Identify the availability of existing activity data on solid fuel consumption and review available emission factors.
3. Depending on the importance of the source and the quality of available statistics, decide whether to conduct a household survey.
4. If needed, design and carry out the survey, and collect any other fuel data that may be necessary.
5. Scale activity data up (if derived from a survey) and/or down (if a top-down approach is used).
6. Calculate total emissions for each type of combustion device, combining emission factors, activity data and any other data required. Allow for any regulations that may restrict burning on certain days.
7. Aggregate emissions across equipment types for each pollutant.

8. Spatially and temporally disaggregate as required.

4.1.1.2.6. Comments on reliability

Household surveys should yield reasonably reliable results, providing the surveys are carefully designed and executed. Top-down approaches (e.g. using national fuel consumption data) will generally be inferior, as they assume uniform activity rates and do not generally account for wood collected by individual households from forests. The smaller the study region is in relation to the region for which general activity data apply and the greater the differences (e.g. climate, housing type) between the study region and the larger region, the less accurate this approach will be.

In addition, using fuel consumption statistics also means that supplementary data are required on the share of fuel used by different types of combustion devices. This may be another significant source of error. A decision to use this approach must take into account the overall likely significance of this source to total emissions of the pollutants being considered in the inventory.

Emission factors based on local testing will generally be superior to those developed in other countries. In particular, emission factors for HAPs based on standard speciation profiles will generally be of low reliability.

4.1.1.2.7. Sources of further information

Australia

- Environment Australia (1999), Emissions Estimation Technique Manual for Aggregated Emissions from Domestic Solid Fuel Burning (Environment Australia, Canberra, Australia). <http://www.npi.gov.au/system/files/resources/0af0be7a-d872-cd34-858f-f35a1119a85d/files/solidfuelrev2.pdf>.

Canada

- Environment Canada (2013), Manual for the Compilation of Canada's 2013 Air Pollutant Emissions (Environment Canada, Ottawa, Canada). http://publications.gc.ca/collections/collection_2013/ec/En14-87-2013-eng.pdf.

Europe

- EEA (2016), EMEP/EEA Air Pollutant Emission Inventory Guidebook (European Environment Agency, Copenhagen, Denmark), 2016 Edition. <http://www.eea.europa.eu/publications/emep-eea-guidebook-2016>.
- EC (2011), Methodology development for the spatial distribution of the diffuse emissions in Europe, (European Commission, European Union, Luxembourg) https://www.eea.europa.eu/data-and-maps/data/european-pollutant-release-and-transfer-register-e-prtr-regulation-art-8-diffuse-air-data/methodology-report/diffuse_releases_e-prtr_methodology_2011_en.pdf.

US

- US EPA (1995-2018), Compilation of Air Pollutant Emission Factors, Volume I: Stationary Point and Area Sources, AP-42 (United States Environmental Protection Agency, North Carolina, US), 5th Edition <https://www.epa.gov/air-emissions-factors-and-quantification/ap-42-compilation-air-emissions-factors>.

- US EPA (2001), Residential Wood Combustion, Chapter 2 from Volume III of EIIP Document Series, Prepared by Radian Corporation and Eastern Research Group, Inc., (United States Environmental Protection Agency, North Carolina, US) https://www.epa.gov/sites/production/files/2015-08/documents/iii02_apr2001.pdf.
- US EPA (1999), Residential and Commercial/Institutional Coal Combustion, Area Source Method Abstract from Volume III of EIIP Document Series (United States Environmental Protection Agency, North Carolina, US). <https://www.epa.gov/sites/production/files/2015-08/documents/coal.pdf>.

4.1.1.3. *Liquid fuels combustion*

4.1.1.3.1. Nature of the source and relevant pollutants

Non-point, liquid fuel combustion sources primarily include commercial and domestic combustion units used for process heating and space heating. Liquid fuels typically include distillate oils, such as kerosene and diesel fuels, and liquefied petroleum gas. Liquefied petroleum gas (LPG or LP-gas) consists of propane, propylene, butane, and butylenes; the product used for domestic heating is composed primarily of propane. Emissions can include both filterable and condensable particulate matter (PM), SO_x, NO_x, CO and VOC as well as CO₂, CH₄, N₂O and various metallic compounds and organic HAPs.

4.1.1.3.2. Factors affecting releases

Air pollutant emissions from liquid fuel combustion depend on the grade and composition of the fuel, the type and size of the combustion unit, the firing and loading practices used, and the level of equipment maintenance. Emissions also depend on the type of installed control devices, such as filters or catalytic converters.

4.1.1.3.3. Description of release estimation techniques

Techniques for estimating emissions typically involve multiplying the quantity of fuel consumed by an emissions factor, taking into account whether the combustion unit has an installed control device.

$$\text{Emissions} = (\text{fuel consumed} * \text{EF}) * \text{control efficiency}$$

Emission factors are provided in the US EPA's Compilation of Air Pollutant Emission Factors, Volume I: Stationary Point and Area Sources, Chapter 1: External Combustion Sources¹².

4.1.1.3.4. Comments on reliability

Most available emissions factors have a low quality rating and may not be representative of the specific combustion conditions for which emissions are being estimated. Careful matching of combustion conditions between the combustion unit and the reported conditions associated with published emissions factors is important.

4.1.1.3.5. Sources of further information

- US EPA (1995-2018), Compilation of Air Pollutant Emission Factors, Volume I: Stationary Point and Area Sources, AP-42 (United States Environmental Protection

¹² <https://www3.epa.gov/ttn/chief/ap42/ch01/index.html>

Agency, North Carolina, US), 5th Edition, Chapter 1: External Combustion Sources, Sections 1.3 and 1.5. <https://www3.epa.gov/ttn/chief/ap42/ch01/index.html>.

4.1.2. Fuel distribution

4.1.2.1. Gasoline distribution

4.1.2.1.1. Nature of the source and relevant pollutants

Evaporative emissions of VOCs occur at different stages along the gasoline distribution system. This starts at petroleum refineries or tanker ships and includes various storage, transfer and retail facilities (for further information on the gas distribution system, refer to Figure 5.2.1 in AP-42)¹³. Emissions from the refining process and major storage terminals are normally dealt with as point sources. Within the remaining parts of the supply chain, emissions from service stations and associated activities are likely to be the most significant. Emissions generated from the following activities (note that all except the first occur at service stations) are dealt with here:

- gasoline trucks in transit;
- unloading of fuel from tankers to underground storage tanks;
- underground tank breathing/emptying;
- vehicle refuelling; and
- spillage.

Note that AP-42 also deals with losses from the loading of rail, ships and trucks, as well as ballasting losses and cargo transit losses.

The specific VOCs that may be relevant to a particular inventory include benzene, toluene, styrene and xylenes.

4.1.2.1.2. Factors affecting releases

Emissions of VOCs will depend on Reid vapour pressure (RVP) and the nature of vapour recovery systems in place. Stage I vapour recovery applies during the transfer of gasoline from tank trucks to storage tanks at service stations, while Stage II vapour recovery applies during the transfer of fuel to motor vehicle tanks. The Stage I technology for loading tanks (splash loading, submerged loading or vapour balance) has a major impact on the release of displacement emissions. Stage I controls are more widely implemented than Stage II. Note that while this section discusses gasoline, evaporative emissions from other fuels, such as diesel and LPG, can also be estimated (e.g. see Australia's NPI manual on

¹³ US EPA (1995-2018), Compilation of Air Pollutant Emission Factors, Volume I: Stationary Point and Area Sources, AP-42, Chapter 5: Petroleum Industry (United States Environmental Protection Agency, North Carolina, US), 5th Edition. <https://www3.epa.gov/ttn/chief/ap42/ch05/final/c05s02.pdf>.

emissions from service stations¹⁴). However, the emissions from other fuels tend to be relatively small due to their low volatility.

4.1.2.1.3. Description of release estimation techniques

The basic method used to estimate emissions from gasoline distribution involves the use of published emission factors together with information on the volume of gasoline distributed. Hence, the appropriate activity data needed is total fuel sold within the inventory region. Fuel sales data (which are normally obtainable from either government or industry sources) may have to be scaled down from a larger area. This scaling could be based on relative VKT or population.

The EIIP document on gasoline marketing¹⁵ describes methodologies and provides emission factors (from AP-42) for the first three of the five activities listed above. To estimate emissions from the unloading of fuel from trucks to underground tanks, information on the amounts of fuel delivered according to each method (submerged, splash, vapour balancing) is required. If this information is not readily available, a survey of service stations representative of the study region (this should include both large and small service stations) could be carried out.

Stage II emissions for vehicle refuelling activities including spillage can be calculated using EPA's MOtor Vehicle Emission Simulator (MOVES¹⁶). MOVES is a modelling system that estimates emissions from mobile sources at the national, county, and project level for greenhouse gases, criteria pollutants, and air toxics. The Clean Air Act requires EPA to update their mobile source emissions models regularly. MOVES, updated in 2014, represents the most up-to-date on-road mobile source emissions. Information and data on evaporative emissions from fuel leaks, temperature effects on running PM emissions, and automatic adjustments to default fuel properties, such as RVP, were included in the 2014 update to MOVES.

The EMEP/EEA Guidebook (Section 1.B) covers emissions from underground tanks at service stations and from motor vehicle refuelling. It contains emission factors (expressed in grams per mega gram) designed for a simpler approach, applicable to three broad components of gasoline distribution (i.e. refinery dispatch, transport and service stations) that could be used across a whole country or large region. Emission factors provided for more detailed sub-categories (as in EIIP) are also provided for more precise estimations.

The same activity data (i.e. fuel consumption within the inventory region) should also be used to estimate emissions from storage tank breathing and vehicle refuelling. If these data are unavailable, relative VKT or population could be used to scale down national or state data.

The EIIP document on gasoline marketing describes a method for estimating emissions from gasoline trucks in transit. This involves averaging loaded and unloaded components and making an adjustment for gasoline transported twice within the region.

¹⁴ <http://www.npi.gov.au/system/files/resources/5310d8c0-7667-0004-71f1-03e044e70993/files/servstatnsrev4.pdf>

¹⁵ https://www.epa.gov/sites/production/files/2015-08/documents/iii11_apr2001.pdf

¹⁶ <https://www.epa.gov/moves/latest-version-motor-vehicle-emission-simulator-moves>

Tables 11.3-3 and 11.3-4 in the EIIP document on gasoline marketing summarise all preferred and alternative methods applicable in the US. The emission factors do not vary, only the nature of the activity data.

If total VOCs are to be speciated into organic compounds such as benzene, local data on liquid and vapour composition of gasoline should ideally be obtained. If vapour composition is not available, this can be calculated from liquid composition data which are, generally, more readily available (refer to Australia's NPI manual on service stations for the algorithm).

4.1.2.1.4. Spatial allocation

The spatial allocation of emissions from service stations could be based on employment data, population density, actual facility locations, zoning or business district locations. The use of employment data or exact facility locations is superior to population density as the latter may not accurately reflect service station locations. If exact facility locations are identified for the purposes of spatial allocation, then an even higher level of accuracy would involve varying emissions within relevant grid squares according to throughput of each outlet (i.e. effectively treating service stations as point sources). If the applicability of Stage I or II controls varies across the inventory region according to spatial criteria, then the spatial allocation of emissions should, if possible, reflect this variation.

4.1.2.1.5. Summary of steps in the process

1. Determine the availability of activity and other data (e.g. gasoline consumption, extent and nature of Stage I and II vapour recovery technologies, fuel composition, RVP and temperature).
2. Collect data and conduct additional surveys of service stations if necessary.
3. Calculate emissions for each sub-category, using emission factors and/or MOBILE 5A.
4. Aggregate emissions across different sub-categories.
5. Spatially and temporally disaggregate emissions as required.

4.1.2.1.6. Comments on reliability

The nature of the activity data used will influence accuracy. If activity data apply precisely to the study region and reliable data on vapour recovery technologies are available, the accuracy should be reasonably good. The use of international emission factors could reduce accuracy, as local gasoline formulations and temperatures may be different. Speciating VOCs into organic HAPs is likely to be inaccurate if local data on fuel composition are not used. Spatial accuracy will vary according to the method used, as described in Section 3.6.

4.1.2.1.7. Sources of further information

Australia

- Environment Australia (1999), Emissions Estimation Technique Manual for Aggregated Emissions from Service Stations (Environment Australia, Canberra, Australia <http://www.npi.gov.au/system/files/resources/5310d8c0-7667-0004-71f1-03e044e70993/files/servstansrev4.pdf>).

Europe

- EEA (2016), EMEP/EEA Air Pollutant Emission Inventory Guidebook (European Environment Agency, Copenhagen, Denmark), 2016 Edition. <http://www.eea.europa.eu/publications/emep-eea-guidebook-2016>.
- EC (2011), Methodology development for the spatial distribution of the diffuse emissions in Europe, (European Commission, European Union, Luxembourg) https://www.eea.europa.eu/data-and-maps/data/european-pollutant-release-and-transfer-register-e-prtr-regulation-art-8-diffuse-air-data/methodology-report/diffuse_releases_e-prtr_methodology_2011_en.pdf.

US

- US EPA (1995-2018), Compilation of Air Pollutant Emission Factors, Volume I: Stationary Point and Area Sources, AP-42 (United States Environmental Protection Agency, North Carolina, US), 5th Edition. <https://www.epa.gov/air-emissions-factors-and-quantification/ap-42-compilation-air-emissions-factors>.
- US EPA (2001), Gasoline Marketing (Stage I and Stage II), Chapter 11 from Volume III of EIIP Document Series, Prepared by Eastern Research Group, Inc. (United States Environmental Protection Agency, North Carolina, US). https://www.epa.gov/sites/production/files/2015-08/documents/iii11_apr2001.pdf.

4.1.2.2. Natural gas distribution

4.1.2.2.1. Nature of the source and relevant pollutants

Fugitive emissions occur along various parts of the transmission and distribution system that brings gas from a terminal to consumers via pipelines, compressor stations and storages. Natural gas distribution networks consist of a national or state transmission system using large diameter high-pressure pipelines, and regional supply systems with smaller, low-pressure pipelines. Emissions occur as a result of various types of small leaks and losses. These include leaks through joints and cracks, and losses from excavator damage, purging of new mains, gas lost on start-up and shutdown of compressors. At the consumer end, losses occur from leaking lines at fittings and leaking appliance valves.

The most important pollutant emitted from natural gas distribution sources is methane (CH₄), a greenhouse gas. VOCs should also be considered in an air emissions inventory, although natural gas distribution is generally a relatively minor source of VOCs.

4.1.2.2.2. Factors affecting releases

Important determinants of emissions include the types of materials used in networks, the number and condition of joints in pipes, operating pressures, maintenance, leak detection and repair programmes, and measures in place to collect gas during commissioning, decommissioning etc.

4.1.2.2.3. Description of release estimation techniques

A detailed method presented in the EMEP/EEA Guidebook (Section 1) involves dividing the pipeline into categories, each with common emissions characteristics. The data required are length (kilometres) and pressure (mbar) for each category, and the number of point sources (gas holders, compressor stations) installed. The Guidebook provides examples of pipeline categories, plus default emission factors for these categories. Storage facilities and

processing plants are normally treated as point sources; compressor stations may also be considered as point sources if appropriate data are available.

A simpler method involves using a single emission factor and total sales of gas in a region. An estimate of unaccounted-for gas and gas composition data is required from the relevant distributors. The emission factors can be expressed in terms of proportion of total gas sales or in tonnes per PJ of energy. In the latter case, gas calorific value data (MJ per cubic metre) is also needed in order to calculate emissions. Default emission factors for CH₄ and VOCs in different countries (tonnes per PJ) are provided in the EMEP/EEA Guidebook.

In Australia, leakage from the high-pressure transmission is very small, as it is relatively new and built to high standards. Most leaks are from the low-pressure distribution network and, therefore, only these losses have been considered in the release estimation process.

4.1.2.2.4. Spatial allocation

Any emissions from a high-pressure transmission network should be spatially allocated as line sources according to the location of pipelines. Emissions from a regional low-pressure distribution network would normally be based on population density. If a detailed methodology is followed, major installations (terminals, storage, processing plants and large compressor stations) could be spatially located as point sources.

4.1.2.2.5. Summary of steps in the process

1. Identify relevant parts of the gas distribution network within the study region and the sections which need to be dealt with according to likely losses.
2. Determine what data are available on gas consumption, estimated losses and gas composition, plus spatial data for different elements of the network.
3. Decide whether to use the detailed or simple method according to the data available, the objectives of the inventory and the significance of the source.
4. Collect the required data and estimate emissions.
5. Spatially and temporally disaggregate as required.

4.1.2.2.6. Comments on reliability

The nature of the activity data and emission factors used (i.e. to what extent they reflect the actual situation) will determine the accuracy of estimated emissions. The detailed method will be superior to the simple method. However, if greenhouse gases are not included in the inventory, the simple method may be adequate, as VOCs from this source are, generally, relatively minor.

4.1.2.2.7. Sources of further information

Australia

- NGGIC (1996), Australian Methodology for the Estimation of Greenhouse Gas Emissions and Sinks, Workbook 2.1 (revision 1) (Department of the Environment, Sport and Territories, Canberra, Australia).

Europe

- EEA (2016), EMEP/EEA Air Pollutant Emission Inventory Guidebook (European Environment Agency, Copenhagen, Denmark), 2016 Edition. <http://www.eea.europa.eu/publications/emep-eea-guidebook-2016>.
- EC (2011), Methodology development for the spatial distribution of the diffuse emissions in Europe, (European Commission, European Union, Luxembourg) https://www.eea.europa.eu/data-and-maps/data/european-pollutant-release-and-transfer-register-e-prtr-regulation-art-8-diffuse-air-data/methodology-report/diffuse_releases_e-prtr_methodology_2011_en.pdf.

International

- IPCC (2006), 2006 Intergovernmental Panel on Climate Change Guidelines for National Greenhouse Gas Inventories Prepared by the National Greenhouse Gas Inventories Programme, Eggleston H.S., Buendia L., Miwa K., Ngara T. and Tanabe K. (eds). Published: IGES, Japan. <http://www.ipcc-nggip.iges.or.jp/public/2006gl/>.

US

- US EPA (2019), Inventory of U.S. Greenhouse Gas Emissions and Sinks 1990-2017, Chapter 3. Energy, EPA 430-R-19-001, <https://www.epa.gov/sites/production/files/2019-04/documents/us-ghg-inventory-2019-main-text.pdf>.

4.2. Summary of Techniques for Mobile Sources

4.2.1. Mobile sources

Road traffic is generally the most significant source of many common pollutants and HAPs in urban areas, and the estimation methods are among the most complex of those used in air emissions inventories. The other mobile sources covered (aircraft, ships and garden maintenance) are among the next most significant in this group.

4.2.1.1. Road traffic

4.2.1.1.1. Nature of the source and relevant pollutants

The road traffic sector includes different types of vehicles: passenger cars, commercial vehicles, trucks, buses and motor bicycles. Off-road vehicles such as trail bikes and snowmobiles are normally considered separately in inventories. Exhaust pollutants from on-road vehicles result from the burning of fossil fuels in the engine. Various pollutants are produced as by-products of the combustion process, including a range of VOCs, NO_x, CO, SO₂, particles, lead and other metals.

VOC emissions also result from the evaporation of volatile substances, mainly from gasoline (diesel fuel has a much lower vapour pressure). These emissions occur in several ways:

- diurnal losses: as air temperature rises during the day, the temperature of the fuel increases leading to increased vapour loss;
- running losses: heat from the engine and exhaust system vaporises gasoline during vehicle operation;

- hot soak losses: evaporation continues after the engine is turned off; and
- resting losses: vapour is lost through various leaks and permeation through rubber components.

Particles, metals and polycyclic aromatic hydrocarbons (PAHs) are also emitted from brake wear, tyre wear, and engine oil leaks. Tyre tread wear is a complex physio-chemical process which is driven by the frictional energy developed at the interface between the tread and the pavement. Tyre wear particles and road surface wear particles are therefore inextricably linked. However, for the purpose of determining emission factors, tyre wear and road surface wear must, at present, be treated as separate particle sources due to the lack of experimental data on the emission factors associated with different tyre-road surface combinations. Brake wear is the mechanical abrasion of brake linings/pads due to friction during stopping.

4.2.1.1.2. Factors affecting releases

The main factors affecting vehicle emissions are:

- vehicle type;
- type and composition of fuel used;
- vehicle age;
- types of roads where vehicles travel;
- types of tyres; and
- type of brakes.

Emission controls in force at the time a vehicle is manufactured will have a major impact on emissions. Hence, it is necessary to break vehicle fleet data down into age classes and relate these to periods when different levels of controls were in force. (For example, exhausts from the latest gasoline vehicles are controlled by catalytic converters and necessitate the use of unleaded petrol.) For in-service vehicles, the emissions control technology, condition of emission control equipment and state of maintenance are generally reflected in emission factors for different age classes of vehicles.

Emissions also vary significantly with the mode of operation, involving factors such as traffic flow and vehicle speeds. These variables are usually reflected in emission factors for different road types. ‘Cold starts’ (that is, the first few minutes of operation of gasoline vehicles when the catalyst does not function properly) also produce significantly higher emissions and should be accounted for in inventories. Factors affecting evaporative emissions are Reid Vapour Pressure (RVP), temperature and number of trips per day. Other relevant factors, but which are generally only considered in detailed local studies, include road conditions and grade.

4.2.1.1.3. Description of release estimation techniques

If extensive local vehicle test data (for both new and in-service vehicles) are available, then emission factors for those vehicle types can be developed from first principles. In the absence of any local data, the best approach would be to use one of the existing software packages (e.g. MOVES or COPERT 5). A wide range of published emission factors are available, expressed in grams per kilometre and/or grams per mega joule. US EPA emission

factors from AP-42 apply to criteria air pollutants whereas the EMEP/EEA Guidebook includes all pollutants required for international reporting purposes.

Conventional inventory methods

Release estimation involves multiplying VKT (vehicle kilometres travelled) figures by emission factors (grams per kilometre travelled). Emission factors need to be weighted according to the structure and composition of the vehicle fleet. The US EPA has a well-known software package called MOVES¹⁷, used to calculate exhaust and evaporative CO, NO_x and VOC emissions for the US passenger and commercial fleet. The following data are required as inputs to the model:

- relative vehicle miles travelled (VMT) by vehicle type (where necessary this will need to be converted from VKT);
- number of vehicles by vehicle type;
- vehicle age distribution;
- fuel information; and
- RVP, average temperature and average daily maximum and minimum temperatures.

Adjustments can also be made according to inspection and maintenance programmes in force, air-conditioning and vehicle speed. Countries where emissions standards are behind those of the US will tend to under-estimate emissions unless an appropriate time lag is built in.

MOVES is developed by the US EPA and was updated in 2014. The California Air Resources Board (CARB) has its own motor vehicle emissions model, EMFAC, which was updated in 2014.

Spatial VKT data are usually available from transport authorities using transport model results. If necessary, traffic count data may be used instead, although it will be more time consuming to derive gridded VKT. The general method for deriving gridded VKT data and relative VKT according to vehicle, fuel and road types is described in Australia's NPI Manual relating to motor vehicles.

In Australia, passenger (gasoline) vehicle emission factors for NO_x, CO and VOCs have been calculated from local vehicle test data. Only one drive cycle has been used for vehicle testing in Australia (rather than separate drive cycles applicable to different road types). Because of this, a method has been developed in Australia involving the division of the test cycle into segments and, from the sampled emissions during each segment, estimating emissions for different road types according to 'splitting factors' (EPAV, 1991^[23]; EPAV, 1996^[24]).

In Europe, the COPERT model has been developed and made available through the EEA, while the European Commission's Joint Research Centre manages the scientific development of the COPERT model. This model is used by many countries in Europe. The COPERT model takes into account the composition of the vehicle fleet, the annual kilometres driven, and specific emission factors per kilometre driven in urban, rural and highway traffic. Vehicles are divided by size, fuel type and emissions legislation level. Hot and cold-start emissions are estimated separately, as well as evaporative emissions. The

¹⁷ <https://www.epa.gov/moves/latest-version-motor-vehicle-emission-simulator-moves>

model requires data on the number of trips (so that cold starts are accounted for explicitly) as well as total VKT. COPERT creates a fuel balance whereby fuel consumption is calculated and compared with statistical fuel data. The difference between these numbers must be less than a certain amount, so the number of annual kilometres travelled is adjusted across vehicle classes and the emissions are calculated repeatedly in an iterative way. Emissions of particles can be estimated using US EPA software MOVES or the COPERT model.

Emission factors for lead and SO₂ are estimated from fuel sulphur content and fuel consumption rates for the various vehicle types. (Refer to Australia's NPI Manual for a description of methodology). Note that unleaded gasoline contains small quantities of lead, so data on the proportion of leaded versus unleaded fuels sold will be required. Emissions of CO₂ can also be calculated from fuel consumption data according to IPCC methodology. The EMEP/EEA Guidebook (Section 1.A.3.b, Tables 3-33 and 3-34) summarises four different approaches used for various pollutants. These categories range from most complex (e.g. NO_x, VOC and CO from gasoline passenger cars) where both speed dependent hot emissions and cold starts, road types, trip lengths and temperatures are taken into account, to the simplest (e.g. SO₂) based on fuel consumption only. The EMEP/EEA methodology also includes greenhouse gases.

On-road measurements

There are several approaches to developing emission factors from on-road measurements, for example through sampling emissions from tunnel vent stacks. Generally, it is only possible to obtain a 'fleet average' emission factor for the particular road sampled. Measurements from any one road or tunnel may not be representative of different road types and fleet mixes. Another disadvantage is that average emission factors do not allow the relative contributions from different vehicle types to be determined, so an inventory that is based on such emission factors will have limited value as a policy analysis tool. The main value of these sorts of approaches is to monitor trends over time and to compare the results with emission factors derived from normal inventory methods and then averaged across the fleet.

One approach to on-road measurement has been developed by CSIRO and EPAV in Australia (EPAV, 1999^[15]). This determines emission factors for CO₂, CO, NO_x and VOC (as well as VOC speciation data) by sampling air above moving traffic on a roadway, capturing emissions from many vehicles and determining an unknown emissions rate by 'ratioing' it to a known emissions rate (CO₂) from the vehicle. CO₂ emissions, directly related to fuel consumption, are well known.

Another approach used in Denmark involves using a dispersion model 'backwards' to calculate emissions from measured concentrations at kerbsides (NERI, 2000^[16]).

The Diffuse Air emissions in the E-PRTR document also describes a gridding methodology of emissions from road transport in Europe. Emissions from road transport are based on vehicle and road class specific emission data sets. Country specific emissions reported to UNFCCC on the base of the TREMOVE model¹⁸ are allocated to different vehicle types. Emissions are then allocated from CLRTAP and UNFCCC per vehicle type to road classes. Emissions by road class and vehicle type are then allocated to roads covered by

¹⁸ <https://www.tmluven.be/en/navigation/TREMOVE>

TRANSTOOLS and not covered by TRANSTOOLS. Regionalized emission per road segment and emissions on the NUTS3 level are distributed to a 5x5 km² (EC, 2011^[25]).

The Diffuse water emissions in the E-PRTR dissemination document describes a method for estimating emissions to water. Emissions are calculated separately for vehicle categories and road types. Emissions for each pollutant are calculated by multiplying the activity rate (distance covered on EU road network) by an emission factor and by a percentage of the emission allocated to compartment x. National emissions are then allocated to NUTS level, gridded, and then allocated to RBDSU level (EC, 2013^[26]).

4.2.1.1.4. Spatial allocation

Road traffic emissions are normally spatially allocated in a linear fashion reflecting some or all traffic routes. The spatial resolution will depend on the scale and purpose of the inventory. Very detailed inventories (e.g. as carried out in London) represent every roadway with VKT based on accurate traffic count data. Most inventories, however, will only identify major traffic routes, with minor roads being spatially allocated according to another indicator such as population density.

4.2.1.1.5. Summary of steps in the process

The general steps in compiling estimates of road traffic emissions can be summarised as follows:

1. Review all relevant sources of vehicle, fuel, emissions and meteorological data.
2. Select the most appropriate emission factors/models and activity data to be used and obtain relevant data.
3. Calculate relative VKT by road type, vehicle and fuel type, and vehicle age.
4. Derive exhaust and evaporative emission factors using selected methods for different pollutants.
5. Speciate VOCs and particles into individual pollutants.
6. Calculate total emissions in each grid cell by combining activity and emissions data.
7. Incorporate temporal variations if required.

4.2.1.1.6. Comments on reliability

In general, vehicle registration data and fuel data available from government and industry sources should be quite reliable. The accuracy of VKT data will depend on the reliability of the particular transport model used and/or traffic count data, including spatial coverage and resolution.

The accuracy of emission factors will depend on the extent to which they accurately represent the local fleet. This will depend on the number and nature of the vehicles tested. If international emission factors/models are used, then accuracy may be low if the vehicle fleet is significantly different from the fleet reflected in the model. Emission factors based on fuel consumption will generally be reliable. Speciation factors are likely to be of low reliability, unless they are based on extensive local testing. Another less obvious reason for reduced accuracy of emission factors includes the nature of the drive cycle on which vehicle testing is based, and whether or not it represents real world conditions.

4.2.1.1.7. Sources of further information

Australia

- EPAV (1991), Air Emissions Inventory Port Phillip Control Region: Planning for the Future, SRS 91/001 (EPA, Victoria, Australia).
- EPAV (1996), National Pollutant Inventory: Technical Report on the Air Emissions Trials for the NPI, Volume 2 (Commonwealth of Australia, Canberra, Australia).
- EPAV (1999), Measurements of Motor Vehicle Pollutants and Fleet Average Emission Factors in Melbourne, Publication No. 652 (EPA, Victoria, Australia).

Europe

- EEA (2016), EMEP/EEA Air Pollutant Emission Inventory Guidebook (European Environment Agency, Copenhagen, Denmark), 2016 Edition. <http://www.eea.europa.eu/publications/emep-eea-guidebook-2016>.
- COPERT 5 model, <https://copert.emisia.com/>.
- NERI (2000), Benzene from Traffic (Ministry of Environment and Energy, National Environmental Research Institute, Roskilde, Denmark), http://www2.dmu.dk/1_Viden/2_publicationer/3_fagrappporter/rapporter/fr309.pdf.
- EC (2011), Methodology development for the spatial distribution of the diffuse emissions in Europe, (European Commission, European Union, Luxembourg) https://www.eea.europa.eu/data-and-maps/data/european-pollutant-release-and-transfer-register-e-prtr-regulation-art-8-diffuse-air-data/methodology-report/diffuse_releases_e-prtr_methodology_2011_en.pdf.
- EC (2013), Diffuse water emissions in E-PRTR, (European Commission, European Union, Luxembourg), [http://fis.freshwatertools.eu/files/MARS_resources/Info_lib/Deltares\(2013\)Diffuse%20water%20emissions%20in%20E-PRTR%202013%20project%20report.pdf](http://fis.freshwatertools.eu/files/MARS_resources/Info_lib/Deltares(2013)Diffuse%20water%20emissions%20in%20E-PRTR%202013%20project%20report.pdf).

International

- IPCC (2006), 2006 Intergovernmental Panel on Climate Change Guidelines for National Greenhouse Gas Inventories Prepared by the National Greenhouse Gas Inventories Programme, Eggleston H.S., Buendia L., Miwa K., Ngara T. and Tanabe K. (eds). Published: IGES, Japan. <http://www.ipcc-nggip.iges.or.jp/public/2006gl/>.

US EPA

- US EPA (1992), Procedures for Emission Inventory Preparation, volume IV: Mobile Sources, Office of Mobile Sources (United States Environmental Protection Agency, Washington, D.C., US). <https://nepis.epa.gov/Exe/ZyPDF.cgi/P1009ZEK.PDF?Dockkey=P1009ZEK.PDF>.
- US EPA (1985), Compilation of Air Pollutant Emission Factors, volume II, Mobile Sources, AP-42 (United States Environmental Protection Agency, North Carolina, US), 5th edition. This volume is no longer maintained. More current mobile source emission factors are available using the Office of Transportation and Air Quality (OTAQ) mobile source models (<https://www.epa.gov/moves>).

Other US sources

- MOVES, <https://www.epa.gov/moves/latest-version-motor-vehicle-emission-simulator-moves>.
- CARB EMFAC model, <https://ww2.arb.ca.gov/our-work/programs/mobile-source-emissions-inventory/road-documentation/msei-modeling-tools-emfac>.

4.2.1.2. Aircraft

4.2.1.2.1. Nature of the source and relevant pollutants

There are two main types of aircraft, which use different fuels and have different emission characteristics – gas turbine and reciprocating piston (propeller) planes. Both civilian and military aircraft may need to be considered in inventories. Exhaust emissions resulting from the combustion process include NO_x, SO₂, particles, CO, CO₂, VOCs, organic pollutants and metals. Although there are also evaporative emissions from aircraft operations, no emission factors are presently available.

Ground and maintenance operations at airports are not included here; if significant, these should be treated as point sources. In terms of urban air quality impacts and airshed modelling, emissions only need to be considered close to the ground within the mixing zone. For greenhouse gases (CO₂) it is necessary to also consider cruising above 1000m. For some reporting purposes (e.g. IPCC), domestic and international flights must be considered separately.

4.2.1.2.2. Factors affecting releases

Exhaust emissions from aircraft depend on the type of aircraft, type of engines and fuel used, and altitude of operation. The landing and take-off (LTO) cycle incorporates all flight and ground level modes below a reference height above ground level, including descent/approach, touchdown, landing run, taxi in, idle and shutdown, start-up and idle, checkout, taxi out, take-off and climb-out. Mixing height can be determined from detailed meteorological data (or a default height of 1000m is frequently chosen). Time in mode (TIM) provides estimates of the time each aircraft spends in each operational mode at a given airport. All operations within the LTO are grouped into four standard modes for which emission data are readily available:

- approach: from 1000m above ground to ground level;
- taxi/idle: applicable to incoming and outgoing aircraft;
- take-off: from commencement of acceleration to 200m above ground level, during which aircraft operates at full throttle; and
- climb-out: from 200m to 1000m above ground level. For greenhouse gases, the cruise mode above 1000m must also be considered.

International emission controls regulate hydrocarbons (HC), NO_x, CO and smoke emissions. CO and HC emissions are highest during idling and taxiing, NO_x during take-off and climb-out.

4.2.1.2.3. Description of release estimation techniques

A reasonably detailed approach to estimating emissions during the LTO cycle is described in Australia's NPI Manual. The data required are as follows:

- location of airports, runways, landing and approach flight paths and associated ground movements;
- number of LTO cycles for each aircraft type at each airport;
- prevalence of different types of engines (and their numbers) and auxiliary power units used by each aircraft type;
- time spent in each of the four operating modes listed above by aircraft type for each airport; and
- time spent operating auxiliary power units at the airport.

These data are normally available from airport authorities, airline companies and other government bodies. If possible, data should be collected for commercial (passenger, freight) flights, business aircraft, general aviation (private, recreation) and military planes. Some information may have to be obtained from individual airports. Emission factors (kg/hr) apply to each engine type of a particular aircraft type for each mode. These emission factors are available from the International Civil Aviation Organisation. It is also necessary to calculate emissions from auxiliary power units (APUs), requiring data on types of APUs and their operational time. If cruise emissions are to be included (for CO₂), the method will need to be varied and fuel consumption data will also be required. Refer to the Tier 3 approach methodology in the EMEP/EEA Guidebook, plus a variation involving the use of fuel data for general aviation and military aircraft for which LTO data are often not available. AP-42 includes default times in mode that could be used for general aviation activity.

It will be necessary to speciate VOCs and particles into HAPs, depending on the pollutants listed in the inventory. Some speciation data are available from CARB and US EPA. For metals except lead, emission factors from the stationary combustion of kerosene (similar to jet fuel) and gasoline (similar to avgas) could be used. The lead content of avgas (which is much higher than for gasoline) should be obtained from oil companies or a default value should be used.

A somewhat simpler method is based on the use of emission factors developed from national statistics on LTO and aircraft/engine types; this assumes all airports in a country are uniform. Default emission factors (expressed in kg of pollutant per LTO cycle) are included in the Australian NPI Handbook and in the US EPA procedures report on mobile sources. This method is not applicable to military aircraft and auxiliary power units. If cruise emissions are to be included and there are no data on cruise distances, it will be necessary to follow an amended approach using total fuel consumption data, as described in the Tier 2 approach methodology in the EMEP/EEA Guidebook.

An even simpler method, most suited for estimating CO₂ emissions only, requires no data on the number of LTOs on an aircraft type basis. The only data required are the total number of LTOs and total fuel used with default emission factors per LTO cycle and cruise emission factors applicable to an average fleet. Refer to the Tier 1 approach methodology in the EMEP/EEA Guidebook.

In the US, the Federal Aviation Administration has developed a computerised calculation tool to streamline the calculation of emissions. This tool includes a database with emission

factors for different engine types. Refer to (US EPA, 1992_[19]), p.143 for details. The US EPA uses its MOVES emissions modelling system to estimate emissions from all non-road mobile sources.

The European Union describes a gridding methodology for emissions from aircrafts using national emissions. The data required are national totals reported to CLRTAP for CO, NO_x, PM₁₀, SO₂ and to UNFCCC for CO₂ emissions. Emissions are distinguished between LTO and cruise. Cruise related emissions are not taken into account since they are above 1000m and do not directly impact regional air quality. Emissions are distributed to 5 km x 5 km grid cells by regionalizing national emission releases and then allocated to the grid using CORINE Land Cover data, an airport data set, and a point data set on airport locations) (EC, 2011_[25]).

4.2.1.2.4. Spatial allocation

Aircraft emissions for the various modes should be spatially allocated to the grid cells in which the flight paths and ground movements occur. Emissions along flight paths should be divided into the four modes and distributed in grid cells in their correct proportions. APU emissions should be assigned to the grid cells where the airport is located.

4.2.1.2.5. Summary of steps in the process

1. Identify civilian and military airports located within study region and sources of activity data.
2. Obtain activity data and assemble relevant emission factors.
3. Calculate emissions for each airport, using the best methodology according to data availability and resources for as many aircraft types as possible.
4. Spatially and temporally disaggregate as required.

4.2.1.2.6. Comments on reliability

Activity data obtained from airports and airline authorities are generally highly reliable. Emission factors for criteria pollutants (CO, hydrocarbons, NO_x) have been derived from manufacturers' test data and should be reasonably reliable. Data on emissions of particulate matter are not always available, hence emission factors may not be based on direct measurements. Speciation profiles have a relatively low reliability. Using simpler methods involves making broad assumptions about the aircraft fleet and times in mode, so accuracy will be reduced. There is a high uncertainty associated with cruise emission factors.

4.2.1.2.7. Sources of further information

Australia

- Environment Australia (2003), Emissions Estimation Technique Manual for Aggregated Emissions from Aircraft, Canberra, Australia, <http://www.npi.gov.au/system/files/resources/7c29f57e-fb3e-a0d4-e5f3-8e3b559d0f75/files/aircraft.pdf>.

Europe

- EEA (2016), EMEP/EEA Air Pollutant Emission Inventory Guidebook (European Environment Agency, Copenhagen, Denmark), 2016 Edition. <http://www.eea.europa.eu/publications/emep-eea-guidebook-2016>.

- EC (2011), Methodology development for the spatial distribution of the diffuse emissions in Europe, (European Commission, European Union, Luxembourg) https://www.eea.europa.eu/data-and-maps/data/european-pollutant-release-and-transfer-register-e-prtr-regulation-art-8-diffuse-air-data/methodology-report/diffuse_releases_e-prtr_methodology_2011_en.pdf.

International

- ICAO (2019), ICAO Aircraft Engine Emissions Data Bank, International Civil Aviation Organisation, Committee on Aviation Environmental Protection, Montreal, Canada. <http://easa.europa.eu/document-library/icao-aircraft-engine-emissions-databank>.
- IPCC (2006), 2006 Intergovernmental Panel on Climate Change Guidelines for National Greenhouse Gas Inventories Prepared by the National Greenhouse Gas Inventories Programme, Eggleston H.S., Buendia L., Miwa K., Ngara T. and Tanabe K. (eds). Published: IGES, Japan. <http://www.ipcc-nggip.iges.or.jp/public/2006gl/>.

US

- CARB (1991b), Identification of Particulate Matter Species Profiles, ARB Speciation Manual Vol. 2, 2nd Edition, California Air Resources Board, US.
- US EPA (1992), Procedures for Emission Inventory Preparation, Volume IV: Mobile Sources (Office of Mobile Sources, US EPA, Washington D.C., US). <https://nepis.epa.gov/Exe/ZyPDF.cgi/P1009ZEK.PDF?Dockey=P1009ZEK.PDF>.
- US EPA (2019), Estimating Emissions from Aircraft, <https://www.epa.gov/moves/emissions-models-and-other-methods-produce-emission-inventories#aircraft>.
- NONROAD model. US EPA's NONROAD model is now incorporated into the MOVES model. <https://www.epa.gov/moves/latest-version-motor-vehicle-emission-simulator-moves>.

4.2.1.3. Ships

4.2.1.3.1. Nature of the source and relevant pollutants

This section covers cargo and passenger ships, tankers, colliers and naval ships. Smaller craft, such as tugs, fishing and recreational boats (less than 100 gross tonnes) should be considered separately. The normal combustion products – including PM, CO, CO₂, VOCs, NO_x, SO₂, N₂O and HAPs are relevant. Shipping activities also result in emissions of PAHs, metals, and other substances from coatings, sacrificial anodes, bilge water, and sanitary wastewater to water. Most ships are powered by diesel engines, both for propulsion and auxiliary power. A small number are powered by steam turbine propulsion or gas turbines.

4.2.1.3.2. Factors affecting releases

Commercial ships emit pollutants under two main modes, while sailing and at berth under auxiliary power. At berth, diesel generators normally supply auxiliary power used for lighting, heating, pumps, refrigeration and ventilation. During the sailing mode, emissions

come from both the exhaust and the auxiliary power systems. Exhaust emissions are influenced by many factors, including engine size, fuel used, operating speed and load.

In addition, there are fugitive emissions from the loading and ballasting of petroleum tankers in port as vapour is vented to the atmosphere. Ballasting emissions occur when vapour-laden air in the empty cargo tank is displaced to the atmosphere by ballast water being pumped into the tank. These emissions may occur at dock or some distance out to sea. Diesel loading is less significant as this fuel is relatively non-volatile. The loading and unloading of cargoes such as grain may release particles to the atmosphere, and incinerators on ships may be another source of emissions.

4.2.1.3.3. Description of release estimation techniques

Australia's NPI Manual describes a relatively detailed methodology. The following data are required:

- location of ports;
- number of ships visiting in a year in various tonnage ranges;
- average number of hours at berth;
- average speed in shipping channels; and
- locations and lengths of shipping channels.

These data should be obtainable from port authorities and/or waterway/channel authorities. For major ports, Lloyd's Maritime Information Service has data on ship movements (for ships greater than 250 tonnes) worldwide. Emission factors for main and auxiliary engines vary with tonnage ranges; these are available from Lloyd's Register (expressed in kg/hr). Emissions should be estimated by combining the number of hours at berth and in channels with the relevant time-based emission factors for each weight category. Speciation data can be obtained from CARB and Lloyds, although it is preferable to use local diesel exhaust data if available. Note that many ships use light oil while in harbour then change to heavy oil (with high sulphur content) outside the harbour. Starting from 1 January 2020, the limit for sulphur in fuel oil used on board ships operating outside designated emission control areas will be reduced from 3.50% to 0.50% mass by mass¹⁹.

Another method, the Tier 3 approach, based on fuel consumption, is described in the EMEP/EEA Guidebook. This involves less spatial resolution but may be suitable when statistics on fuel use for ship categories are available and emissions are more aggregated spatially (e.g. for national greenhouse gas inventories). Emission factors (expressed in kg/tonne) are available (e.g. from Lloyd's Register). There are single emission factors for pollutants other than NO_x, for which a speed-based factor should be used. Fuel use data can be obtained from shipping companies or government sources.

A simple method, the Tier 2 approach, described in the EMEP/EEA Guidebook uses fuel sold and average emission factors (kg/tonne) according to fuels used. This method is appropriate for CO₂ emissions, even if the more detailed EMEP/EEA method described above is used for other pollutants.

19

<http://www.imo.org/en/MediaCentre/HotTopics/GHG/Documents/2020%20sulphur%20limit%20FAQ%202019.pdf>

To estimate emissions from loading and ballasting, data is required on the volume of petroleum liquid loaded at port, the number of tankers involved in loading and unloading, average deadweight tonnage of tankers, and the proportion of ballast emissions at berth. These data should be available from port and oil companies. Emission factors are provided in US EPA AP-42 (Volume I). Profiles for gasoline and crude oil evaporative emissions should be used for speciating VOCs.

International shipping needs to be taken into account for greenhouse gas inventories, but for urban air inventories only activity within the airshed needs to be considered.

The EMEP/EEA Guidebook covers other in-port emissions from manoeuvring, and other vessels (e.g. tugs and dredgers).

The US EPA uses its MOVES model to estimate emissions from all non-road mobile sources²⁰.

Emissions to water are calculated by multiplying an activity rate (the number of ton-kilometres covered on the EU surface waters) by an emission factor. Activity rates are available for most EU member states and are produced per the member state. National and total amounts of ton-kilometres traversed by ships per member state are available in EUROSTAT. Emission factors are calculated using data from the PRTR of the Netherlands (EC, 2013_[26]).

4.2.1.3.4. Spatial allocation

Emissions from ships in port (at berth, loading and ballasting) should be allocated to the port areas. Emissions from sailing should be distributed along the shipping channels.

The Diffuse Air emissions in E-PRTR document describes a gridding methodology of emissions in the shipping sector in Europe. Emissions from shipping are gridded using traffic volume data from TRANSTOOLS, traffic data from VNF, and river geo data from GISCO (HYDR). Global shipping proxies are first used to allocate international inland waterway shipping emissions to grid cells (EC, 2011_[25]).

4.2.1.3.5. Summary of steps in the process

1. Identify relevant ports and availability of required data.
2. Decide on methodology according to inventory objectives, data available and resources.
3. Collect data and estimate emissions from ships in channels, at berth (and where relevant), loading and ballasting. If required for greenhouse gases also estimate emissions at sea also.
4. Spatially and temporally disaggregate as required.

4.2.1.3.6. Comments on reliability

Shipping data obtained from port and marine authorities are generally reliable. Emission factors from Lloyd's Register are also considered to be reliable. Emissions associated with loading and ballasting are likely to be less accurate. The use of speciation profiles for metals and organic compounds will be of low reliability, particularly if not based on local fuel

²⁰ <https://www.epa.gov/moves/nonroad-technical-reports>

data. The detailed method will provide more accurate results than simpler approaches. NO_x emissions are highly dependent on engine type, so very simple approaches may result in a low level of accuracy for this pollutant.

4.2.1.3.7. Sources of further information

Australia

- Environment Australia (1999), Emissions Estimation Technique Manual for Aggregated Emissions from Commercial Ships/Boats and Recreational Boats (Environment Australia, Canberra, Australia). <http://www.npi.gov.au/system/files/resources/8a6079c5-fae1-0fd4-31b7-69a026bd0a17/files/shipping.pdf>.

Europe

- EEA (2016), EMEP/EEA Air Pollutant Emission Inventory Guidebook (European Environment Agency, Copenhagen, Denmark), 2016 Edition. <http://www.eea.europa.eu/publications/emep-eea-guidebook-2016>.
- EC (2013), Diffuse water emissions in E-PRTR, (European Commission, European Union, Luxembourg), [http://fis.freshwatertools.eu/files/MARS_resources/Info_lib/Deltares\(2013\)Diffuse%20water%20emissions%20in%20E-PRTR%202013%20project%20report.pdf](http://fis.freshwatertools.eu/files/MARS_resources/Info_lib/Deltares(2013)Diffuse%20water%20emissions%20in%20E-PRTR%202013%20project%20report.pdf).
- EC (2011), Methodology development for the spatial distribution of the diffuse emissions in Europe, (European Commission, European Union, Luxembourg) https://www.eea.europa.eu/data-and-maps/data/european-pollutant-release-and-transfer-register-e-prtr-regulation-art-8-diffuse-air-data/methodology-report/diffuse_releases_e-prtr_methodology_2011_en.pdf.

International

- Lloyd's Register (1995), Marine Exhaust Emissions Research Programme (Lloyd's Register, Croydon, UK).
- Lloyds's Register (1997), Marine Diesel Engine Particulate Emissions, AA Wright, Trans IMarE, Vol 109, Part 4, 345-364.

US

- CARB (1991a), Identification of Volatile Organic Compound Species Profiles, ARB Speciation Manual: Volume 1 (California Air Resources Board, California, US) 2nd edition.
- CARB (1991b), Identification of particulate matter species profiles, ARB Speciation Manual: Volume 2 (California Air Resources Board, California, US) 2nd edition.
- US EPA (2019), SPECIATE Version 5.0, <https://www.epa.gov/air-emissions-modeling/speciate-2>.
- US EPA (1995-2018), Compilation of Air Pollutant Emission Factors, Volume I, Stationary Point and Area Sources, AP-42 (United States Environmental Protection Agency, Research Triangle Park, North Carolina, US) 5th edition. <https://www.epa.gov/air-emissions-factors-and-quantification/ap-42-compilation-air-emissions-factors>.

- US EPA (2019), Estimating Commercial Marine Emission Inventories and Port Emissions, <https://www.epa.gov/moves/emissions-models-and-other-methods-produce-emission-inventories#marine>.

4.2.1.4. Garden maintenance

4.2.1.4.1. Nature of the source and relevant pollutants

The types of equipment that emit pollutants directly to the atmosphere include:

- two-stroke lawn mowers;
- four-stroke lawn mowers;
- tractors; and
- rotary tillers, chain saws, leaf blowers, snow blowers, shredders and other equipment.

The US EPA EIIP report on lawn and garden equipment lists 12 categories of equipment²¹. The EMEP/EEA Guidebook lists six categories. In the US, lawn mowers are the biggest contributor to emissions in this category.

Electric mowers and tools generate emissions indirectly through electricity generation. These emissions would be accounted for in a PRTR as point-source emissions from power stations and, therefore, are not considered here as a non-point source.

All criteria pollutants are emitted from these types of equipment, and include CO, lead, NOx, particles, SO₂, and total VOCs. HAPs emitted include PAHs, organic compounds such as benzene, 1,3-butadiene, toluene and xylenes, and metals and their compounds such as chromium, manganese and nickel. The relative quantities and proportions of these pollutants will depend very much on the type of equipment. For example, four-stroke mowers have lower emissions of VOCs, CO and particulate matter than traditional two-stroke mowers, but higher emissions of NOx.

4.2.1.4.2. Factors affecting releases

The use of lawn mowers and other equipment will obviously vary significantly from one country or region to another. Usage rates can also vary within a study region. Important factors to consider when deciding how important this source of emissions might be include:

- climate, availability of water and nature of vegetation;
- residential land use patterns and to what extent suburban households have lawns; and
- non-domestic lawns and gardens, including consideration of the extent of public open space, golf courses, roadside verges, commercial and industrial lawns and open space.

As mentioned above, identifying the use pattern of each of the different equipment types is important. The fuel type (diesel, leaded or unleaded petrol) also influences emissions. Depending on the equipment type and emission factors being used, other information about the equipment (e.g. age, power rating) may also be relevant.

²¹ <https://www.epa.gov/sites/production/files/2015-08/documents/iv03.pdf>

Usage is likely to vary significantly with season, day of week and time of day. If the emissions inventory is to be used for airshed modelling, then temporal activity data are required (or assumptions will need to be made based on data from elsewhere).

4.2.1.4.3. Description of release estimation techniques

Sources of emission factors

Emission factors for two and four stroke small utility engines and agricultural equipment (including tractors) are provided in US EPA AP-42 Volume II. The emission factors do not account for evaporative losses.

Emission factors developed in Europe for different classes of engines and fuels are provided in the EMEP/EEA Guidebook (Chapter 1).

Emission factors may be expressed in terms of:

- grams per kilowatt hour or horsepower hour;
- grams per litre or gallon of fuel used;
- grams per hour of use; or
- grams per unit-year (assuming a specified annual usage).

Activity data need to match the emission factors being used, so data collected through survey methods may need to be supplemented by additional data to complement the chosen emission factors. The different possibilities include:

- use emission factors based on fuel consumption and fuel consumption activity data;
- use emission factors based on power output, activity rates based on use per hour (or year) combined with power rating data for each type of equipment;
- use emission factors based on fuel consumption, activity rates based on use per hour combined with fuel efficiency (fuel use per hour) data; or
- use emission factors based on hours of use and activity rates based on use per hour.

Fuel composition, in terms of lead and sulphur content, should be compared with the default fuels on which the emission factors are based and the emission factors should be adjusted accordingly. Refer to the Australian NPI Manual for guidance on this. The emission factors that are currently available are not designed to be adjusted to account for fuel volatility.

Activity data

Using fuel consumption or general activity data. The simpler, but less accurate ‘top-down’ approach is to use nationally compiled statistics. The statistics most likely to be available would be on fuel consumption and obtainable from the relevant national government agency or industry association. These are unlikely to be disaggregated down to particular equipment types as the same fuels are normally used for other mobile sources (e.g. motor vehicles, small boats). Hence, general fuel consumption data must be combined with estimates of the numbers of two-stroke mowers, four-stroke mowers (and other equipment being considered) in use or the proportion of total fuel they consume.

In the US, national data on activity rates (hours of use per year) for different types of equipment are available, so these can be used in combination with time-based emission factors.

Fuel consumption or other national activity data will need to be scaled down (normally on the basis of relative population) to the study region.

Conducting surveys. A more accurate approach is to conduct a sample survey of domestic premises and any other significant users of mowers and garden equipment in non-domestic areas. If there are other domestic sources for which activity data are required and relevant information can be gathered at the same time, then a household survey is more likely to be cost-effective. A household survey should obtain data on amount of use (hours) over a year for each piece of equipment, type(s) of mowers and other garden equipment, fuel types, and if required for modelling, temporal variations in use. Although fuel use data could be sought rather than hourly use data, this approach is less likely to produce accurate data from households. Depending on fuels available and whether deterioration is being taken into account, it may be desirable to include questions on the use of leaded versus unleaded fuel and on the age of equipment. The questions should cover use of mowers and equipment by commercial operators, unless a separate survey of commercial mowing/gardening services is planned (as suggested by US EPA in their EIIP document on estimating lawn and garden equipment activity levels²²).

Data from the sampled households are scaled up according to total study region household numbers. If there are expected to be significant differences in use within a study region (for example, if there are differences in housing types and private gardens in different parts of the study region), partitioning of the survey into two or more sub-regions could be considered to improve spatial accuracy. However, this significantly increases costs as each sub-region must be considered separately and will require a similar level of sampling.

A detailed description of the major approaches to estimating activity data from surveys is provided in the US EPA EIIP document on estimating lawn and garden equipment, which suggests telephone or door-to-door methods for surveying households.

A mail survey approach to conducting household surveys has been developed and refined during trials of Australia's NPI. This has been found to generate response rates of 50-55% in a number of different study regions. Guidelines for conducting domestic surveys are included in Appendix A of the NPI Manual on domestic lawn mowing.

In many study regions, emissions of some pollutants from mowing and garden/lawn maintenance in commercial and other non-domestic situations may be significant. For example, if there are extensive areas of open space and golf courses, then NO_x emissions are likely to be relatively high due to the greater use of four-stroke diesel-powered mowers. Emissions from these activities could be estimated by surveying the relevant authorities or clubs (e.g. local municipalities or parks authorities, private golf clubs, road maintenance agencies). It may be difficult to obtain hours of use data from these sources, but they would normally be able to supply fuel consumption statistics. In the situation of some agencies not responding, data provided by responding agencies could be used to scale up total emissions, using data on relative proportions and total open space and golf course coverage. This approach has been used in an air emissions inventory in Melbourne, Australia (EPAV, 1998_[27]).

As mentioned, the mowing of domestic lawns by commercial operators could be estimated either through a domestic survey (relying on householders' knowledge of mowing times, mower types etc.) or by a separate survey of the companies themselves. In the latter case, the household survey must be designed so that double counting does not occur by relating

²² <https://www.epa.gov/sites/production/files/2015-08/documents/iv03.pdf>

only to mowing done by the householders or others not connected with commercial companies.

Expert statistical and survey design advice should always be sought prior to conducting surveys. The following issues must be considered in order ensure an adequate response rate and to ensure that reliable data are obtained:

- careful design of the layout and wording of questionnaires to facilitate data entry and avoid ambiguity; ask questions that people can reasonably be expected to answer, and formulate them so as to obtain only data that will be used;
- wording used in cover letters, introductory comments and general manner for telephone or door-to-door surveys;
- sample size;
- pilot surveys;
- follow-up approaches to increase response rates; and
- quality control procedures.

4.2.1.4.4. Spatial allocation

Domestic emissions would normally be spatially allocated according to household or population distribution. If the survey has been partitioned into sub-regions, then emissions will need to be scaled up and spatially allocated in each sub-region separately. Emissions from non-domestic sources could be allocated within specific open space areas, but this approach may not be warranted given the effort involved.

4.2.1.4.5. Summary of steps in the process

1. Decide on the sectors of activity to be covered (e.g. domestic, park maintenance, commercial operations) and the types of equipment to be considered.
2. Review and select the most appropriate emission factors and activity data to be used, and the nature of surveys that may be conducted.
3. Design and carry out surveys. Obtain any other relevant data (e.g. fuel composition, fuel efficiency).
4. Scale activity data up (if based on a sample survey) or down (if a top-down approach is used).
5. Calculate total emissions for each type of equipment by combining activity data, emission factors (adjusted if necessary) and any other data required.
6. Aggregate emissions across equipment types for each pollutant.
7. Spatially and temporally disaggregate as required.

4.2.1.4.6. Comments on reliability

Household and other surveys should yield reasonably reliable results, providing that the surveys are carefully designed and executed. Top-down approaches (e.g. using national fuel consumption data) will generally be significantly inferior, as they assume uniform activity rates. The smaller the study region is in relation to the region for which general activity data apply, and the greater the differences (e.g. climate, vegetation, housing type)

between the study region and the larger region, the less accurate this approach will be. In addition, using fuel consumption statistics also means that supplementary data are required on the share of fuel used by different types of equipment. This may be another significant source of error.

Although surveys are preferable, a decision to use this approach must take into account the overall likely significance of these sources to total emissions of the pollutants being considered in the inventory.

Emission factors based on local testing will generally be superior to international default values. Emissions of HAPs based on standard speciation profiles will be of relatively low reliability.

4.2.1.4.7. Sources of further information

Australia

- Environment Australia (1999), Emissions Estimation Technique Manual for Aggregated Emissions from Domestic Lawn Mowing (Environment Australia, Canberra, Australia), <http://www.npi.gov.au/system/files/resources/775a55ca-2c34-6434-11cc-13d988e40ec7/files/lawnmowingrev2.pdf>.
- EPAV (1998), Port Phillip Air Emissions Inventory (EPA, Victoria, Australia), http://www.epa.vic.gov.au/air/emissions_inventory/default.asp. (Available from EPA Information Centre, GPO Box 4395QQ, Melbourne 3001, Victoria, Australia)

Europe

- EEA (2016), EMEP/EEA Air Pollutant Emission Inventory Guidebook (European Environment Agency, Copenhagen, Denmark), 2016 Edition. <http://www.eea.europa.eu/publications/emep-eea-guidebook-2016>.

US

- US EPA (1985), Compilation of Air Pollutant Emission Factors, Volume II, Mobile Sources, AP-42 (United States Environmental Protection Agency, North Carolina, US), 5th edition. This volume is no longer maintained. More current mobile source emission factors are available using the Office of Transportation and Air Quality (OTAQ) mobile source models (<https://www.epa.gov/moves>).
- US EPA (1997), Guidance for Estimating Lawn and Garden Equipment Activity Levels, Chapter 3 from Volume IV of the EIIP Document Series, prepared by E.H. Pechan & Assoc., US (United States Environmental Protection Agency, North Carolina, US). <https://www.epa.gov/sites/production/files/2015-08/documents/iv03.pdf>.
- US EPA (1992), Procedures for Emission Inventory Preparation, Volume IV: Mobile Sources (Office of Mobile Sources, United States Environmental Protection Agency, Washington, D.C., US). <https://nepis.epa.gov/Exe/ZyPDF.cgi/P1009ZEK.PDF?Dockkey=P1009ZEK.PDF>.

4.3. Summary of Techniques for Stationary non-combustion

Three industrial activity categories are discussed here: mineral products, chemical industry, and metal production.

4.3.1. Mineral products

4.3.1.1. Cement production

4.3.1.1.1. Nature of the source and relevant pollutants

Cement manufacture, a major mineral commodity industry, transforms finely ground natural raw materials into cement clinker in a kiln system at high temperatures. Clinker is an intermediate product that is then finely ground, along with a small proportion of calcium sulphate (gypsum ($\text{CaSO}_4 \cdot 2\text{H}_2\text{O}$) or anhydrite (CaSO_4)), into hydraulic, typically Portland, cement. Once cooled, the clinkers are ground together with other additions into a fine powder known as cement.

Cement production occurs in four stages:

- extraction of raw materials and pre-processing of raw materials – extracted raw materials include limestone, chalk, marl and shale, or clay extracted from quarries usually close to the plant while other raw materials, such as bauxite, iron ore, blast furnace slag, sand, or recycled material, are brought in from elsewhere;
- pyroprocessing to produce clinker – the production of clinker occurs in the kiln system where the minerals from raw materials are transformed at high temperatures into new minerals with hydraulic properties;
- blending and grinding of clinker to cement – Portland cement is produced by grinding cement clinker and sulphates such as gypsum and anhydrite together; and
- storage, packing and delivery of cement – the cement is stored in silos and transferred directly to bulk road, rail or ship tankers or to a bagging station.

The main emissions from cement production are emissions to the air from the kiln system. Emissions from the cement kiln system are from the physical and chemical reactions of raw materials with the fuel used. Nitrogen and excess oxygen from combustion air and carbon dioxide and water from raw materials and the combustion process are the main constituents of exit gases in cement production.

CO_2 is produced during the production of clinker, in which limestone, mainly consisting of calcium carbonate (CaCO_3), is heated to produce lime (CaO) and CO_2 as a by-product. Cement can be produced from imported clinker, in which case the cement production facility would be considered to have zero CO_2 process related emissions.

Emissions from cement production, as discussed here, only consider particulate matter and CO_2 . The emissions of other pollutants, NO_x , SO_x , CO, non-methane volatile organic compounds (NMVOC), and NH_3 , are mainly from the combustion of fuel. Therefore, these emissions are included under stationary combustion emissions.

4.3.1.1.2. Factors affecting releases

The main environmental concern from cement manufacturing is dust, including particulate matter. Dust occurs mainly from the stacks of the kiln system, along with some additional emissions from the various grinding of raw materials, fuels, and cement and from storage and handling of raw materials, clinker, cement, and fuels. The dust emissions from cement manufacturing have become more controlled and reduced due to increases in efficient filters.

The cement industry is strictly regulated through national and international legislation on environmental protection. Due to these regulations, emission levels of pollutants are determined by abatement technologies applied to comply with regulations.

4.3.1.1.3. Description of release estimation techniques

The PM₁₀, PM_{2.5}, TSP, and BC emissions from cement production are estimated using the following Tier 1 equation:

$$E_{\text{pollutant}} = AR_{\text{production}} \times EF_{\text{pollutant}}$$

where:

$E_{\text{pollutant}}$ = the emission of a pollutant (kg)

$AR_{\text{production}}$ = the annual production of cement (in Mg)

$EF_{\text{pollutant}}$ = the emission factor of the relevant pollutant (in kg pollutant / Mg cement produced)

National total cement production data are used in the emissions equation. The data are widely available from the United Nations statistical yearbooks or national statistics.

The emission factors for emissions from cement production, as provided in the 2016 EMEP/EEA Air Pollutant Emission Inventory Guidebook, are: 260 g/Mg clinker for TSP, 234 g/Mg clinker for PM₁₀, 130 g/Mg clinker for PM_{2.5}, and 3 percent of PM_{2.5} for BC. The mass figures are based on an average 2,300 m³/ton clinker and 1 million tons of clinker per year. The emission factors are provided for particulate fractions only and include the additional emissions resulting from the handling and processing of the product and raw materials.

The emission factors assume an average or typical technology and abatement implementation for the country and integrate all the sub-processes in cement production.

The CO₂ emissions from cement production are estimated using the following Tier 1 equation:

$$\text{CO}_2 \text{ Emissions} = \{ \sum_i (M_{ci} \cdot C_{cli}) - \text{Im} + \text{Ex} \} \cdot EF_{\text{clc}}$$

where

CO₂ Emissions = emissions of CO₂ from cement production, tonnes

M_{ci} = weight (mass) of cement produced of type i , tonnes

C_{cli} = clinker fraction of cement of type i , fraction

Im = imports for consumption of clinker, tonnes

Ex = exports of clinker, tonnes

EF_{clc} = emission factor for clinker in the particular cement, tonnes CO₂/tonne clinker. The default clinker emission factor (EF_{clc}) is corrected for cement kiln dust

The emission factor for CO₂, as provided in the 2006 IPCC Guidelines for National Greenhouse Gas Inventories, is 0.52 tonnes CO₂/tonne clinker. In the absence of carbonate input data or national clinker production data, cement production data may be used to estimate clinker production. In order to use cement production data, the amounts and types of cement produced and their clinker contents, including a correction for clinker imports and exports, must be taken into account. The imports and exports of clinker are important

to include in the estimation of emissions as the emissions from production of imported clinker would not be included in the national emissions estimate for the source as they were produced and accounted for in another country and the emissions from exported clinker should be factored into the national emission estimates for the country where the clinker is produced.

In some cases, the production of cement is taken to mean production of cement plus the exports of clinker. It is good practice to subtract clinker exports from the M_{ci} factor in the CO_2 equation above if this is the case.

For the PM_{10} , $PM_{2.5}$, TSP, and BC emission estimate equation, activity data must be recalculated from cement to clinker production data as the emission factors are expressed as mass of clinker produced. The CO_2 emission estimate equation use the clinker fraction of cement, by type of cement. Portland cement, the most common cement produced, has an average clinker content of 90-97 percent.

4.3.1.1.4. Spatial allocation

Cement production plants should be considered as point sources if emissions can be calculated from available plant-specific data. Otherwise, national emissions should be disaggregated based on plant capacity, employment or population statistics to calculate non-point source emissions.

4.3.1.1.5. Summary of steps in the process

1. Identify activity data on cement production.
2. Identify the clinker content percent for the cement produced. Recalculate activity data from cement production to clinker production data if necessary.
3. Calculate total emissions by combining activity data, emission factors (adjusted if necessary) and any other data required.
4. Spatially and temporally disaggregate as required.

4.3.1.1.6. Comments on reliability

Since the emissions from cement production due to the combustion of fuels are not included in this section, it is good practice to check whether the data used in the mineral production emissions from cement are consistent with the associated fuel use in the section on emissions from combustion.

The clinker fraction of the cement produced is the major component of uncertainty in the estimation of CO_2 emissions. If reliable import and export data are not available, the uncertainty of the clinker production estimate will be higher. Though the default cement kiln dust correction factor has a high level of uncertainty, the effect it has on the overall calculation of emissions is ultimately lower than the uncertainty from the clinker fraction.

The uncertainty of activity data can be as high as 35 percent where clinker production data are estimated from cement production.

4.3.1.1.7. Sources of further information

Europe

- EEA (2016), EMEP/EEA Air Pollutant Emission Inventory Guidebook (European Environment Agency, Copenhagen, Denmark), 2016 Edition. <http://www.eea.europa.eu/publications/emep-eea-guidebook-2016>.

International

- IPCC (2006), 2006 Intergovernmental Panel on Climate Change Guidelines for National Greenhouse Gas Inventories Prepared by the National Greenhouse Gas Inventories Programme, Eggleston H.S., Buendia L., Miwa K., Ngara T. and Tanabe K. (eds). Published: IGES, Japan. <http://www.ipcc-nggip.iges.or.jp/public/2006gl/>.

US

- US EPA (1995-2018), Compilation of Air Pollutant Emission Factors, Volume I, Stationary Point and Area Sources, Chapter 11: Mineral Products Industry, Section 11.6, Portland Cement Manufacturing. AP-42 (United States Environmental Protection Agency, North Carolina, US), 5th Edition. <https://www3.epa.gov/ttn/chief/ap42/ch11/final/c11s06.pdf>.

4.3.1.2. Lime production

4.3.1.2.1. Nature of the source and relevant pollutants

The production of lime (CaO), the high-temperature product of calcination of limestone, occurs in vertical and rotary kilns that are fired by coal, oil, or natural gas. Calcium limestone is made predominately of calcium carbonate, with the remainder being magnesium carbonate, aluminium oxide, iron oxide, and silica.

Limestone is excavated from a quarry and transferred to a facility to be crushed and ground into sizes able to fit in several types of kilns. Limestone can reach a temperature of 900°C during the kiln operations, driving off carbon dioxide and leaving quicklime, which is cooled and discharged from the kiln. Adding water to crushed or ground quicklime and thoroughly mixing creates hydrated lime.

Emissions from the production and manufacture of lime include particulate matter emissions from the mining, handling, crushing, screening, and calcining of the limestone as well as emissions generated during the combustion of fuel in the kilns. Heating limestone in vertical or rotary kilns at high temperatures also releases CO₂.

Emissions from lime production, as discussed here, only consider particulate matter and CO₂. The emissions from the main pollutants, NO_x, SO_x, CO, NMVOC, CH₄, and N₂O, from the kiln are mainly from the combustion of fuel. Therefore, these emissions are included in the stationary combustion emissions.

4.3.1.2.2. Factors affecting releases

Two major types of kilns are used in the production of lime – vertical and rotary kilns. Due to the larger size of charge material, lower air velocities, and less agitation, vertical kilns have lower particle emissions but higher SO₂ and CO emissions.

Modern lime production equipment are equipped with electrostatic precipitators that remove at least 98 percent of particulate matter from exhaust gases.

4.3.1.2.3. Description of release estimation techniques

The CO₂, PM₁₀, PM_{2.5}, TSP, and BC emissions from lime production are estimated using the following Tier 1 equation:

$$E_{\text{pollutant}} = AR_{\text{production}} \times EF_{\text{pollutant}}$$

where

$E_{\text{pollutant}}$ = the emission of the specified pollutant

$AR_{\text{production}}$ = the activity rate for the lime production

$EF_{\text{pollutant}}$ = the emission factor for this pollutant

This equation is applied using national total lime production activity data at the national level. Data on national levels of lime production can be found in the United Nations statistical yearbooks or national statistics.

It is important to note that when collecting activity data on lime production that both marketed and non-marketed lime production are included, as some industries produce lime and consume it for their own operations. However, finding activity data on non-marketed lime production may be challenging and can require inventory compilers to identify potential industries where non-marketed lime may be produced and inquire whether there is such production occurring.

Inventory compilers can use default values for either the type of lime produced and/or the proportion of hydrated lime produced. When there are no disaggregated data on the breakdown of lime types available, it is good practice to assume that 85 percent is high-calcium lime and 15 percent is dolomitic lime. It should be assumed that the proportion of hydraulic lime is zero unless other information is available. If hydraulic lime data are available, it is good practice to include a correction for hydrated lime. The correction is calculated by multiplying the production data by a correction factor, $1 - (x \cdot y)$ where x is the proportion of hydrated lime and y the water content in it. Since most hydrated lime that is produced is high-calcium (90 percent), the default values for x are 0.10 and y are 0.28, resulting in a correction factor of 0.97.

This method for determining emissions from lime production does not incorporate a correction for lime kiln dust.

The emission factors for PM₁₀, PM_{2.5}, TSP, and BC, as provided in the 2016 EMEP/EEA Air Pollutant Emission Inventory Guidebook, are: 3,500 g/Mg lime for PM₁₀, 700 g/Mg lime for PM_{2.5}, 9,000 g/Mg lime for TSP, and 0.46 percent of PM_{2.5} for BC.

The emission factors for CO₂, as provided in the 2006 IPCC Guidelines for National Greenhouse Gas Inventories, is based on the stoichiometric ratio of tonne of CO₂ per tonne lime or dolomitic lime, depending on the type of lime produced. High-calcium lime use a CO₂ emission factor of 0.75 tonnes CO₂ per tonne lime, dolomitic lime uses a CO₂ emission factor of 0.86 or 0.77 tonnes CO₂ per tonne lime (depending on the technology used for lime production, with the higher value suggested for developed countries and the lower for developing countries), and hydraulic lime uses a CO₂ emission factor of 0.59 tonnes CO₂ per tonne lime.

4.3.1.2.4. Spatial allocation

Lime production plants should be considered as point sources if emissions can be calculated from available plant-specific data. Otherwise, national emissions should be disaggregated

based on plant capacity, employment or population statistics to calculate non-point source emissions.

4.3.1.2.5. Summary of steps in the process

1. Identify activity data on lime production.
2. Identify the type of lime produced and the percentage each type of lime produced is to the total. For hydraulic lime, if data exist, calculate the correction factor and apply it to the hydraulic lime production activity data.
3. Calculate total emissions by combining activity data, emission factors (adjusted if necessary) and any other data required.
4. Spatially and temporally disaggregate as required.

4.3.1.2.6. Comments on reliability

Since the emissions from fossil fuel combustion from lime production are included in the stationary combustion section, it is good practice to check whether the lime production data included here are consistent with the associated fuel use reported for lime production.

It is possible to considerably underestimate emissions due to excluding lime sources because of problems with activity data. The uncertainty for lime production activity data can come from omission of non-marketed lime production, which could lead to order of magnitude underestimates as well as the correction for hydrated lime. The uncertainty from activity data is likely to be much higher than uncertainty associated with the emission factors. Since the stoichiometric ratio used to develop emission factors is an exact number, the emission factor uncertainty is the uncertainty of the lime composition, particularly the share of hydraulic lime.

4.3.1.2.7. Sources of further information

Europe

- EEA (2016), EMEP/EEA Air Pollutant Emission Inventory Guidebook (European Environment Agency, Copenhagen, Denmark), 2016 Edition. <http://www.eea.europa.eu/publications/emep-eea-guidebook-2016>.

International

- IPCC (2006), 2006 Intergovernmental Panel on Climate Change Guidelines for National Greenhouse Gas Inventories Prepared by the National Greenhouse Gas Inventories Programme, Eggleston H.S., Buendia L., Miwa K., Ngara T. and Tanabe K. (eds). Published: IGES, Japan. <http://www.ipcc-nggip.iges.or.jp/public/2006gl/>.

US

- US EPA (1995-2018), Compilation of Air Pollutant Emission Factors, Volume I, Stationary Point and Area Sources, Chapter 11: Mineral Products Industry, Section 11.17, Lime Manufacturing. AP-42 (United States Environmental Protection Agency, North Carolina, US), 5th Edition. <https://www3.epa.gov/ttn/chief/ap42/ch11/final/c11s17.pdf>.

4.3.1.3. Glass production

4.3.1.3.1. Nature of the source and relevant pollutants

The production of glass includes four particular types: flat glass, container glass, glass wool, and other specialty glass which include hand-shaped glassware, lighting glass, television screens, and optical glass. Glass is produced by large multinational companies as well as small and medium-sized enterprises.

Since glass production produces a large variety of glasses with different chemical compositions, a large variety of raw materials are used in production. Raw materials include silica sand, lime or limestone, dolomite, recycled waste glass and soda for the production of soda lime silica glass and lead oxide, potash, and zinc oxide for the production for specialty glass. The raw materials are usually delivered to the production site in a prepared form. Recycled glass pieces, also known as cullet, are the only materials that undergo additional processing steps such as sieving and sorting out impurities and non-glass materials. In Europe, 85 percent of glass produced is made of soda lime silica with flat and container glass being the main type of glass produced. Typically, 20 to 25 percent of melted flat glass and up to 90 percent of melted container glass come from recycled glass.

The emissions from glass production include CO₂, micro pollutants, metals, black carbon, and dust. Emissions related to combustion activities within the glass industry are not covered in this section, but are included in the stationary combustion methodology. The main raw materials that emit CO₂ during the melting process in the production of glass are limestone, dolomite, and soda ash. These materials should be included in the emissions estimations where they are mined as carbonate minerals for their use in the glass industry and therefore represent primary CO₂ production. When carbonate materials are produced through the carbonation of a hydroxide and do not result in CO₂ emissions, they should not be included in the emissions estimate. Several other raw materials, including barium carbonate, bone ash, potassium carbonate, and strontium carbonate, emit minor levels of CO₂ during the glass production process. Powdered anthracite coal or other organic material may also be added to create reducing conditions in the molten glass and will combine with available oxygen in the glass melt to produce CO₂. The action of carbonates in the fusion of glass is a high-temperature chemical reaction which results in emissions of CO₂. The retention of dissolved CO₂ in glass is determined to be relatively insignificant and can be ignored for the purposes of GHG emissions estimation.

4.3.1.3.2. Factors affecting releases

Emission reduction measures in the glass industry are mostly aimed at reducing emissions NO_x and SO_x. These measures include:

- lowering the amount of excess air;
- reduced air preheating;
- staged combustion;
- flue gas recirculation;
- reburning / 3R process;
- low NO_x glass melting furnaces;
- oxy-fuel firing;

- electric melting;
- Selective Non-Catalytic Reduction (SNCR); and
- Selective Catalytic Reduction (SCR)

Reductions in emissions from the handling of raw materials can be achieved through the use of fabric filters or improved handling techniques. The emissions of carbon dioxide from the carbonisation process can be reduced by adding more recycled glass or using non-carbonate basic materials as well as through fossil fuel energy saving measures.

4.3.1.3.3. Description of release estimation techniques

The CO₂ emissions from glass production are estimated using the following Tier 1 equation:

$$\text{CO}_2 \text{ Emissions} = M_g \times \text{EF} \times (1 - \text{CR})$$

where

CO₂ emissions = the emissions of CO₂ from glass production, tonnes

M_g = the mass of glass produced, tonnes

EF = the default emission factor for manufacturing of glass, tonnes CO₂/tonne glass

CR = the cullet ratio for process (either national average or default), fraction

The default emission factor is based on a typical raw material mixture – typical soda-lime glass production might consist of sand (56.2 weight percent), feldspar (5.3 percent), dolomite (9.8 percent), limestone (8.6 percent) and soda ash (20.0 percent). Based on this default composition, a metric tonne of raw material would yield approximately 0.84 tonnes of glass, losing 16.7 percent of its weight as volatiles, virtually entirely as CO₂ in this case. The default emission factor would be 0.2 tonnes of CO₂ per tonne of glass.

The activity data for the CO₂ emission estimation technique are national statistics for glass production by weight along with a correction for the amount of cullet used during the production process. A default cullet ratio of 50 percent is assumed in the Tier 1 methodology, unless country specific data are available.

The micro pollutants, metals, black carbon, and dust emissions from glass production are estimated using the following Tier 1 equation:

$$E_{\text{pollutant}} = \text{AR}_{\text{production}} \times \text{EF}_{\text{pollutant}}$$

where:

E_{pollutant} = the emission of the specified pollutant

AR_{production} = the activity rate for the glass production

EF_{pollutant} = the emission factor for this pollutant

The activity data for glass production is based on national level data, which is widely available from United Nations statistical yearbooks or national statistics. The emission factors assume an average or typical technology and abatement implementation and integrate all the sub-processes in glass production between inputting the raw material and the final shipment off the facilities.

The default emission factors are from an assessment of emission factors for flat and container glass, as they represent 80 percent of the European glass industry, with an average distribution of two-thirds container glass and on-third flat glass. The emission factors for emissions from glass production, as provided in the 2016 EMEP/EEA Air Pollutant Emission Inventory Guidebook, are: 300 g/Mg glass for TSP; 270 g/Mg glass for PM₁₀; 240 g/Mg glass for PM_{2.5}; 0.062 % of PM_{2.5} for BC; 1.7 g/Mg glass for Pb; 0.13 g/Mg glass for Cd; 0.003 g/Mg glass for Hg; 0.19 g/Mg glass for As; 0.23 g/Mg glass for Cr; 0.007 g/Mg glass for Cu; 0.49 g/Mg glass for Ni; 0.8 g/Mg glass for Se; and 0.37 g/Mg glass for Zn.

Though emissions from fluorine and chlorine originate from the production of glass, they are not in the reporting requirements and not included in the 2016 EMEP/EEA Air Pollutant Emission Inventory Guidebook. The black carbon emission factors are assumed to be equal to those for elemental carbon for the purposes of this guidance. The emission of lead often depends on the amount of recycled external glass and the quality of the cullet.

4.3.1.3.4. Spatial allocation

Glass production plants should be considered as point sources if emissions can be calculated from available plant-specific data. Otherwise, national emissions should be disaggregated based on plant capacity, employment or population statistics to calculate non-point source emissions.

4.3.1.3.5. Summary of steps in the process

1. Identify activity data on glass production.
2. For CO₂ emissions, determine the cullet ratio if national level data exist. If not, use the default cullet ratio.
3. Calculate total emissions by combining activity data, emission factors (adjusted if necessary) and any other data required.
4. Spatially and temporally disaggregate as required.

4.3.1.3.6. Comments on reliability

Since the CO₂ emission estimation technique uses the cullet ratio, uncertainty can arise if specific national level cullet ratio data are unavailable and the default value is used. Uncertainty can also arise from the raw material mixture default estimation values used to develop the emission factors for CO₂.

The glass production data are typically measured fairly accurately (+/-5 percent) for Tier 1 however, inventory compilers should be cautious where activity data are not originally available in mass, but rather as a unit (e.g. bottle) or area (e.g. m²). Converting activity data to mass can result in additional uncertainty.

4.3.1.3.7. Sources of further information

Europe

- EEA (2016), EMEP/EEA Air Pollutant Emission Inventory Guidebook (European Environment Agency, Copenhagen, Denmark), 2016 Edition. <http://www.eea.europa.eu/publications/emep-eea-guidebook-2016>.

International

- IPCC (2006), 2006 Intergovernmental Panel on Climate Change Guidelines for National Greenhouse Gas Inventories Prepared by the National Greenhouse Gas Inventories Programme, Eggleston H.S., Buendia L., Miwa K., Ngara T. and Tanabe K. (eds). Published: IGES, Japan. <http://www.ipcc-nggip.iges.or.jp/public/2006gl/>.

US

- US EPA (1995-2018), Compilation of Air Pollutant Emission Factors, Volume I, Stationary Point and Area Sources, Chapter 11: Mineral Products Industry, Section 11.15, Glass Manufacturing. AP-42 (United States Environmental Protection Agency, North Carolina, US), 5th Edition. <https://www3.epa.gov/ttn/chief/ap42/ch11/final/c11s15.pdf>.

4.3.1.4. *Quarrying and mining of minerals other than coal*

4.3.1.4.1. Nature of the source and relevant pollutants

Non-coal mineral quarrying and mining includes minerals such as bauxite, copper ore, iron ore, manganese ore, or zinc ore. The standard technique assumed for quarrying and mining of these minerals is blasting transportation and crushing of materials. The quarrying and mining of non-coal minerals results in emissions of particulates.

Although emissions are significant at a local level, emissions from non-coal quarrying and mining comparatively small, thought to be less than one percent of the national emissions of any pollutant, and only relevant for the relatively coarse fractions of particulate matter.

The 2016 EMEP/EEA Air Pollutant Emission Inventory Guidebook does provide default emission factors for non-coal quarrying and mining, though the chapter provides a very simple process description and a Tier 1 worst-case approach to estimating emissions. See the EPA's AP 42, Fifth Edition Compilation of Air Pollutant Emission Factors for more detailed information.

4.3.1.4.2. Factors affecting releases

The controls in place that will affect release of emissions include wetting and covering of processes, depending on the materials.

4.3.1.4.3. Description of release estimation techniques

The PM₁₀, PM_{2.5}, and TSP emissions from non-coal quarrying and mining are estimated using the following Tier 1 equation:

$$E_{\text{pollutant}} = AR_{\text{production}} \times EF_{\text{pollutant}}$$

where:

$E_{\text{pollutant}}$ = the emission of the specified pollutant

$AR_{\text{production}}$ = the activity rate for the quarrying/mining

$EF_{\text{pollutant}}$ = the emission factor for this pollutant

The default emission factors are average emission factors taken from the Coordinated European Particulate Matter Emission Inventory Program (CEPMEIP) and assume an average or typical technology and abatement implementation the country while integrating all sub-processes. The emission factors for PM₁₀, PM_{2.5}, and TSP, as provided in the 2016

EMEP/EEA Air Pollutant Emission Inventory Guidebook, are: 50 g/Mg mineral for PM₁₀, 5.0 g/Mg mineral for PM_{2.5}, and 102 g/Mg mineral for TSP.

Activity data and information production statistics is available from the United Nations statistical yearbooks or national statistics.

4.3.1.4.4. Spatial allocation

Production plants for quarrying and mining of minerals other than coal should be considered as point sources if emissions can be calculated from available plant-specific data. Otherwise, national emissions should be disaggregated based on plant capacity, employment or population statistics to calculate non-point source emissions.

4.3.1.4.5. Summary of steps in the process

1. Identify activity data on non-coal quarrying and mining.
2. Calculate total emissions by combining activity data, emission factors (adjusted if necessary) and any other data required.
3. Spatially and temporally disaggregate as required.

4.3.1.4.6. Comments on reliability

There are no specific issues with uncertainty for this source category.

4.3.1.4.7. Sources of further information

Canada

- Environment Canada (2013), Manual for the Compilation of Canada's 2013 Air Pollutant (Environment Canada, Ottawa, Canada). http://publications.gc.ca/collections/collection_2013/ec/En14-87-2013-eng.pdf.

Europe

- EEA (2016), EMEP/EEA Air Pollutant Emission Inventory Guidebook (European Environment Agency, Copenhagen, Denmark), 2016 Edition. <http://www.eea.europa.eu/publications/emep-eea-guidebook-2016>.

International

- IPCC (2006), 2006 Intergovernmental Panel on Climate Change Guidelines for National Greenhouse Gas Inventories Prepared by the National Greenhouse Gas Inventories Programme, Eggleston H.S., Buendia L., Miwa K., Ngara T. and Tanabe K. (eds). Published: IGES, Japan. <http://www.ipcc-nggip.iges.or.jp/public/2006gl/>.

US

- US EPA (1995-2018), Compilation of Air Pollutant Emission Factors, Volume I, Stationary Point and Area Sources, Chapter 11: Mineral Products Industry, AP-42 (United States Environmental Protection Agency, North Carolina, US), 5th Edition. <https://www3.epa.gov/ttn/chief/ap42/ch11/index.html>.

4.3.1.5. Construction and demolition

4.3.1.5.1. Nature of the source and relevant pollutants

The construction of infrastructure and buildings is an important source of fugitive particulate matter emissions. Since construction projects occur in densely populated and urban areas, there are a larger number of people exposed to particulate matter emissions from construction. Elevated levels of ambient PM₁₀ concentrations are often observed at and around construction sites.

Other pollutants emitted from construction activities due to combustion include NO_x, soot and CO₂, and fugitive NMVOC emissions. However, these emissions are covered in other emissions inventory sections, such as emissions from mobile machinery or solvent/product use.

Though construction industry uses the NACE code-based Eurostat economic statistics to provide an overview of the economic activities associated with construction for economic and professional purposes, activities based on the type of building constructed or by considering the emission mechanism of the type of machinery used are needed for an emission inventory. There are multiple activities that occur during typical construction work that are relevant sources of fugitive particulate matter including land clearing and demolition; earth moving and cut and fill operations; equipment movements; mobile debris crushing equipment; vehicular transport (loading, unloading and hauling of materials, track out of dirt on paved roads and subsequent dust resuspension); further site preparation activities; specific building activities such as concrete, mortar and plaster mixing, drilling, milling, cutting, grinding, sanding, welding and sandblasting activities; various finishing activities; and windblown dust from temporary unpaved roads and bare construction sites.

A large portion of fugitive particulate matter emissions are of mineral composition, largely soil dust. Resuspension of soil dust from hauling traffic is a large contributor to construction emissions, but is often estimated in elsewhere increasing the risk of double counting emissions. Since the resuspension of soil dust on construction sites is usually several times higher than normal traffic-induced resuspension, vehicular resuspension of soil dust from construction should be estimated separately from the resuspension of soil dust from normal traffic activity.

4.3.1.5.2. Factors affecting releases

Fugitive dust emissions are highly depending on the material or moisture content of soil. High moisture levels in soil encourage particles to clog together and prevent soil particles from becoming airborne. A simple and effective way to control soil dust emissions is surface watering. During demolition, a water curtain can be used to limit the amount of fugitive dust emissions. The 2016 EMEP/EEA Air Pollutant Emission Inventory Guidebook only discusses watering as an emission control measure, though many more emission reduction measures are available for specific construction related activities. For a more comprehensive overview of these emission-reducing measures, the guidebook recommends the Cheminfo Services Inc. Best Practices for the Reduction of Air Emissions from Construction and Demolition Activities.

4.3.1.5.3. Description of release estimation techniques

The majority of information regarding fugitive particulate matter emission from construction comes from the United States. The US EPA developed a top-down Tier 1

methodology based on downwind dust measurements from construction in the 1990s which has since been adapted for use in all regions of the US. The US EPA methodology is the recommended Tier 1 methodology; however, it should be noted that the methodology was never intended for use outside of the United States²³.

The Tier 1 methodology from the US EPA only considers new construction and does not include renovation or demolishing without any significant new construction. There are no additional emission factors for demolition activities only. The four types of new construction included in the US EPA Tier 1 methodology include:

- Residential housing, single- or two family;
- Residential housing, apartments;
- Non-residential housing; and
- Road construction

The US EPA Tier 1 methodology for estimating emissions from PM₁₀, PM_{2.5}, and TSP uses the following equation:

$$EMPM_{10} = EFPM_{10} \times A_{\text{affected}} \times d \times (1 - CE) \times \left(\frac{24}{PE}\right) \times \left(\frac{s}{9\%}\right)$$

where:

EMPM₁₀ = PM₁₀ emission (kg PM₁₀)

EFPM₁₀ = the emission factor for this pollutant emission (kg PM₁₀/[m² · year])

A_{affected} = area affected by construction activity (m²)

d = duration of construction (year)

CE = efficiency of emission control measures (-)

PE = Thornthwaite precipitation-evaporation index (-)

s = soil silt content (%)

The emission factor used in the US EPA Tier 1 methodology is dependent on the type of construction. The emission factors for each construction type are:

- Construction of houses
 - TSP – 0.29 kg/(m² · year)
 - PM₁₀ – 0.086 kg/(m² · year)
 - PM_{2.5} – 0.0086 kg/(m² · year)

23

<https://nepis.epa.gov/Exe/ZyNET.exe/9100KK1W.txt?ZyActionD=ZyDocument&Client=EPA&Index=1995%20Thru%201999&Docs=&Query=&Time=&EndTime=&SearchMethod=1&TocRestrict=n&Toc=&TocEntry=&QField=&QFieldYear=&QFieldMonth=&QFieldDay=&UseQField=&IntQFieldOp=0&ExtQFieldOp=0&XmlQuery=&File=D%3A%5CZYFILES%5CINDEX%20DATA%5C95THRU99%5CTXT%5C00000027%5C9100KK1W.txt&User=ANONYMOUS&Password=anonymous&SortMethod=h%7C-&MaximumDocuments=1&FuzzyDegree=0&ImageQuality=r75g8/r75g8/x150y150g16/i425&Display=hpfr&DefSeekPage=x&SearchBack=ZyActionL&Back=ZyActionS&BackDesc=Results%20page&MaximumPages=1&ZyEntry=1>

- Construction of apartment buildings
 - TSP – 1.0 kg/(m² · year)
 - PM₁₀ – 0.30 kg/(m² · year)
 - PM_{2.5} – 0.030 kg/(m² · year)
- Non-residential construction
 - TSP – 3.3 kg/(m² · year)
 - PM₁₀ – 1.0 kg/(m² · year)
 - PM_{2.5} – 0.1 kg/(m² · year)
- Road construction
 - TSP – 7.7 kg/(m² · year)]
 - PM₁₀ – 2.3 kg/(m² · year)
 - PM_{2.5} – 0.23 kg/(m² · year)

It is recommended that for construction the average PM_{2.5} content is assumed to be 10 percent of PM₁₀, as is reflected in the emission factors above.

The methodology requires multiplying an emission factor by the total affected area for that type of construction and the average duration of construction, but the total affected area is usually not directly available from statistical sources. It is recommended to implement means of estimating the affected area based on other statistical data.

Several of the calculation parameters used in the Tier 1 equation above have to be set in accordance to country-specific standards. The parameters include the duration of the construction (d); the control efficiency of any applied emission reduction measures (CE); the Thornthwaite precipitation-evaporation index (PE); and the soil silt content (s).

The duration of the construction activity means the total duration of all activities from land clearing and/or demolition to finishing the final structure. An average value may be used when no country specific data is available. The average values based on the type of construction are:

- Construction of houses (detached single family, detached two family and single family terraced) – 0.5 (6 months)
- Construction of apartments (all types) – 0.75 (9 months)
- Non-residential construction (all construction except residential construction and road construction) – 0.83 (10 months)
- Road construction – 1 (12 months)

The control efficiency of any applied emission reduction measures includes watering of temporary unpaved roads. This control measure is widely used in construction in Europe and is a simple and effective emission control measure. Watering occurs routinely in heavy construction activities during dry periods. Watering can result in an overall emissions reduction of 50 percent, which translates to control efficiency used in the Tier 1 methodology emission estimation equation. The following values are used for control efficiencies by type of construction:

- Construction of houses (detached single family, detached two family and single family terraced) – 0
- Construction of apartments (all types) – 0
- Non-residential construction (all construction except residential construction and road construction) – 0.5
- Road construction – 0.5

The Thornthwaite precipitation-evaporation (PE) index is used as an indicator of the soil moisture content. The US EPA Tier 1 methodology provides an option for a rough correction to the climatic conditions that influence soil moisture content. The PE index is calculated based on the monthly precipitation and the mean temperature. Soil moisture content has the strongest influence on soil dust sensitivity. A country-specific PE value can be calculated or taken from an average value. The formula for PE index is:

$$\text{PE index} = 3.16 \sum_{i=0}^{12} \left(\frac{P_i}{1.8T_i + 22} \right)^{\frac{10}{9}}$$

where:

P_i = the monthly precipitation in mm

T_i = the mean temperature in °C

The average values for PE index based on climate to use in place of the above formula are:

- Wet – More than 128
- Humid – 64 - 127
- Sub-humid – 32 - 63
- Semi-arid – 16 - 31
- Arid – Less than 16

The soil silt content is the weight fraction of silt, which is soil with particles sized between 0.002 and 0.075 mm and is fraction of soil that is the most dust sensitive. Construction emissions from silt must be corrected for the average silt content of the top soil of the affected construction area. Average silt content values for varying soil types can include:

- Silt loam – 52
- Sandy loam – 33
- Sand – 12
- Loamy sand – 12
- Clay – 29
- Clay loam – 29
- Loam – 40

Silt content refers to the silt content of the first 1.2 m of undisturbed natural soil. However, occasionally the top layers of soil are too unstable to build directly on and are removed to a certain depth and replaced by sand to prepare a stable base for the subsurface for construction. Due to this factor, the silt content values as taken from soil maps could lead to a significant overestimation of emissions. Sections of the affected area can keep their

natural soil layer on top and remain uncovered throughout the construction process, but only make up a small portion of the total affected area. The majority of the affected area on a construction site will be covered in sand most of the time, with the average silt content value therefore falling somewhere between that of sand and the natural soil. Due to this, the 2016 EMEP/EEA Air Pollutant Emission Inventory Guidebook noted that the average silt content of 20 percent is assumed for Germany, whereas the weighted average silt content as derived from soil maps was 38 percent.

4.3.1.5.4. Spatial allocation

As the US EPA AP-42 methodology requires very detailed local data, e.g. material silt content, road surface silt content, material moisture content, medium wind speed, mean vehicle weight, mean vehicle speed, vehicle kilometre travelled (VKT), such data is likely to be possible only for individual large point sources.

4.3.1.5.5. Summary of steps in the process

1. Identify activity data on construction.
2. Select the most appropriate emission factors/models and activity data to be used and obtain relevant data.
3. Select the type of construction occurring and calculate the affected area, duration of construction, efficiency of control measures, PE index, and soil silt content based on the type of construction.
4. Calculate total emissions for the type of construction by combining activity and emissions data.
5. Spatially and temporally disaggregate as required.

4.3.1.5.6. Comments on reliability

The Tier 1 methodology used here was initially developed for the US, with different building practices than those in Europe which could impact the estimated emissions.

The uncertainty associated with estimated emissions from the construction industry is higher than most other sources of primary particulate matter. Uncertainty lies in the emission factor and activity data. Each piece of activity data has their own uncertainty level, and when combined they result in an additional uncertainty of at least a factor of two, up and down.

Though the methodology allows for corrections in soil moisture and/or silt content, as the correction gets larger the results become more uncertain. The soil moisture content PE index average values were developed for the US and have limited applicability for other regions, but are widely used throughout the world. The PE index could potentially underestimate the soil moisture content of the top layer of soil in European countries as Europe tends to experience longer and more frequent periods of lighter rainfall compared to the US. The correction for different soil moisture can have an extensive influence on the emission results and the applicability the US EPA emission factors could be stretched in these cases.

Total affected area can result in uncertainty because of uncertainties in the estimated components, the building footprint, and the multiplier to calculate affected area. The uncertainty can range from 50 percent to the upper limit of 300 percent as there is

considerable uncertainty to which the estimated average footprint is representative of the actual situation.

Overall, the uncertainty lower and upper limits for the construction industry methodology are estimated at a wide range of 5 – 10 percent and 300 – 500 percent. Since the range is so wide and fugitive construction emissions are largely geological dust, an upper limit on the contribution of emissions from construction can be put in place from the overall soil dust contribution to ambient PM₁₀. This may provide a way to validate and reduce the upper uncertainty range for the construction industry emissions.

4.3.1.5.7. Sources of further information

Canada

- CSI, 2005, Best Practices for the Reduction of Air Emissions From Construction and Demolition Activities, Prepared for Environment Canada - Transboundary Issues Branch, Prepared by: Cheminfo Services Inc (CSI) March, Canada 2005, <http://www.bv.transports.gouv.qc.ca/mono/1173259.pdf>.

Europe

- EEA (2016), EMEP/EEA Air Pollutant Emission Inventory Guidebook (European Environment Agency, Copenhagen, Denmark), 2016 Edition. <http://www.eea.europa.eu/publications/emep-eea-guidebook-2016>.

US

- US EPA (1999), *Estimating Particulate Matter Emissions from Construction Operations, Final Report, prepared for US EPA by Midwest Research Institute*, <https://nepis.epa.gov/Exe/ZyNET.exe/9100KK1W.txt?ZyActionD=ZyDocument&Client=EPA&Index=1995%20Thru%201999&Docs=&Query=&Time=&EndTime=&SearchMethod=1&TocRestrict=n&Toc=&TocEntry=&QField=&QFieldYear=&QFieldMonth=&QFieldDay=&UseQField=&IntQFieldOp=0&ExtQFieldOp=0&XmlQuery=&File=D%3A%5CZYFILES%5CINDEX%20DATA%5C95THRU99%5CTXT%5C0000027%5C9100KK1W.txt&User=ANONYMOUS&Password=anonymous&SortMethod=h%7C-&MaximumDocuments=1&FuzzyDegree=0&ImageQuality=r75g8/r75g8/x150y150g16/i425&Display=hpfr&DefSeekPage=x&SearchBack=ZyActionL&Back=ZyActionS&BackDesc=Results%20page&MaximumPages=1&ZyEntry=1>

4.3.1.6. Storage, handling, and transport of mineral products

4.3.1.6.1. Nature of the source and relevant pollutants

Emissions from storage, handling, and transport of mineral products can occur before, during, and after the activities included in the mineral products section of this document. The most relevant emissions that can occur during the storage, handling, and transport of mineral products are emissions of particulates.

4.3.1.6.2. Factors affecting releases

There are no specific factors affecting releases related directly to storage, handling, and transport of mineral products. Factors affecting releases for individual mineral product emission estimations will be outlined in their respective section.

4.3.1.6.3. Description of release estimation techniques

The Tier 1 emissions from storage, handling, and transport of mineral products are already covered in the technical sections for each individual activity (i.e. cement production, lime production etc.). It is good practice to not report the emissions from storage, handling, and transport separately to avoid double counting.

4.3.1.6.4. Comments on reliability

As the best practice is to assume that the emissions for this source are included in the other mineral products categories, it is recommended to ensure that this is actually the case. There are no specific uncertainties related directly to storage, handling, and transport of mineral products. Uncertainty can lie in the individual mineral product emission estimations, which will be outlined in their respective sections.

4.3.1.6.5. Sources of further information

Europe

- EEA (2016), EMEP/EEA Air Pollutant Emission Inventory Guidebook (European Environment Agency, Copenhagen, Denmark), 2016 Edition. <http://www.eea.europa.eu/publications/emep-eea-guidebook-2016>.

4.3.2. Chemical industry

The chemical industry includes six selected source categories: ammonia production, nitric acid production, adipic acid production, carbide production, soda ash production, and storage, handling, transport of chemical products. Although the products can be very different, all processes in the chemical industry consist basically of a series of comparable unit operations, which can be divided into three major basic categories of equipment: combination (mixing), separation (distillation and other separations), and reaction (chemical reaction). Chemical engineering unit operations and unit processing (fluid flow, heat transfer, mass transfer, thermodynamic, and mechanical processes) form the main principles of all chemical industries and are the foundation of designs of chemical plants, factories, and equipment used.

The chemical industry utilises a large number of different processes in which chemicals are not only used as feedstocks but also as fuels for energy purposes. This means that the distinction and categorisation of emissions from combustion versus non-combustion is not always clear. When such distinctions are difficult to make, emissions can be reported either under the present source category or the industrial combustion source category. In cases where attempts are made to split the emissions from chemical manufacturing between combustion emissions and non-emission combustions, care must be taken to include all emissions. It is good practice to check whether the emissions reported as ‘included elsewhere’ (IE) in are indeed included in the emission reported under the industrial combustion source category.

Depending on the nature of the process, operations can include general basic equipment (heat exchangers, distilling towers) or highly specialised equipment such as high pressure multiphase reactors with internal mixing. More information on unit operations and processes used in chemical industry can be found in encyclopaedias on the chemical industry.

The main air pollutants from chemical processing are: sulphur oxides (SO₂, SO₃) and other sulphur compounds (H₂S, CS₂, COS), nitrogen oxides (NO_x, N₂O) and other nitrogen compounds (NH₃, HCN), halogens and their compounds (Cl₂, Br₂, HF, HCl, HBr), and volatile organic compounds (VOC). Among these pollutants, VOC is often the largest non-point emissions.

Emissions from chemical processing can roughly be divided into ducted and non-ducted (diffuse, fugitive) emissions. Ducted emissions can include the followings:

- process emissions released through a vent pipe by the process equipment and inherent to the running of the plant;
- flue gases from energy-providing units, such as process furnaces, steam boilers, combined heat and power units, gas turbines, or gas engines;
- waste gases from emission control equipment, such as filters, incinerators or absorbers, catalyst regeneration, solvent regeneration, vents from storage and handling, or purge vents or pre-heating equipment; or
- exhaust from general ventilation or vents from captured diffuse/fugitive sources.

Diffuse (un-ducted), also known as fugitive, emissions can arise from point, linear, surface or volume sources under normal operating circumstances, and include the followings:

- process emissions from the process equipment and inherent to the running of the plant, released from a large surface or through openings;
- non-ducted emissions (e.g. working losses and breathing losses) from storage equipment and during handling operations (e.g. filling of drums, trucks or containers);
- non-routine emissions, resulting from operations including emissions during start-up or shutdown and during maintenance;
- emissions from flares;
- secondary emissions, resulting from the handling or disposal of waste (e.g. volatile material from sewers, wastewater handling facilities or cooling water); or
- equipment leaks from pump and compressor seals, valves, flanges, connectors and other piping items or other equipment items, such as drain or vent plugs or seals.

4.3.2.1. Ammonia production

4.3.2.1.1. Nature of the source and relevant pollutants

Ammonia production is based on the ammonia synthesis loop, the Haber-Bosch process, reaction of nitrogen, derived from process air, with hydrogen to form anhydrous liquid ammonia. The hydrogen is derived from feedstock as natural gas, from a conventional steam reforming route, or occasionally from another fuel feedstock, such as residual oil or coke, from partial oxidation, that is being gasified and purified.

Producing hydrogen includes the following processes: removal of sulphur compounds from the feedstock (sulphur deactivates the catalysts used in subsequent steps); catalytic steam reforming of the sulphur-free feedstock to form hydrogen plus carbon monoxide (syngas); and a shift reaction with water to convert the carbon monoxide into carbon dioxide and more hydrogen. This carbon dioxide is removed by absorption in aqueous ethanolamine

solutions or by adsorption in pressure swing absorbers (PSA). Small residual amounts of carbon monoxide or carbon dioxide are removed from the hydrogen through catalytic methanation.

The production of ammonia represents a significant non-energy industrial source of CO₂ emissions. The primary release of CO₂ at plants using the natural gas catalytic steam reforming process occurs during regeneration of the CO₂ scrubbing solution with lesser emissions resulting from condensate stripping.

4.3.2.1.2. Factors affecting releases

Ducted emissions are the only chemical industry emissions that can be controlled. Control/abatement examples include waste gas combustion units (e.g. flares, incinerators) may produce secondary pollutants that did not exist in the original waste stream (e.g. dioxins, particulates), as well as combustion gases; stripping of wastewater (with air or steam) to transfer dissolved organics into the gaseous phase; NMVOCs from wastewater collection systems (e.g. drains, balancing tanks); NMVOCs from wastewater treatment facilities (e.g. vaporisation of NMVOCs in biological treatment units); and NMVOCs and particulates from storage and treatment of solid wastes. Certain controls may produce secondary pollutants that did not exist in the original waste stream (e.g. dioxins, particulates and combustion gases from waste incineration).

Prevention and/or minimisation through recovery and good practice are used for diffused and fugitive emissions controls. Fugitive emissions can be reduced through a Leak Detection and Repair programme (LDAR), which consists of measuring the VOC concentration in the atmosphere around the potential leaking point, then selecting equipment leaking over a defined threshold value and finally operating a repair on those leaking items. More information on abatement in the chemical industry can be found in the BREFs on the various chemical industries, as well as a dedicated BREF document on abatement.

4.3.2.1.3. Description of release estimation techniques

The NO_x, CO, and NH₃ emissions from ammonia production are estimated using the following Tier 1 equation:

$$E_{\text{pollutant}} = AR_{\text{production}} \times EF_{\text{pollutant}}$$

where:

$E_{\text{pollutant}}$ = the emission of a pollutant (kg)

$AR_{\text{production}}$ = the annual production of ammonia

$EF_{\text{pollutant}}$ = the emission factor of the relevant pollutant

The Tier 1 equation is applied at the national level, using annual national total chemical production. Information on the production of chemical compounds, suitable for estimating emissions is widely available from United Nations statistical yearbooks or national statistics.

The Tier 1 emission factors assume an averaged or typical technology and abatement implementation in the country and integrate all sub-processes in the chemical industry between inputting raw material and the final shipment off the facilities. The emission factors, as provided in the 2016 EMEP/EEA Air Pollutant Emission Inventory Guidebook, are: 1kg/t NH₃ for NO_x, 0.1 kg/t NH₃ for CO, and 0.01 kg/t NH₃ for NH₃.

When specific abatement options are to be taken into account, a Tier 1 method is not applicable and a Tier 2 or Tier 3 approach must be used.

4.3.2.1.4. Spatial allocation

Chemical production plants should be considered as point sources if emissions can be calculated from available plant-specific data. Otherwise, national emissions should be disaggregated based on plant capacity, employment or population statistics to calculate non-point source emissions.

4.3.2.1.5. Summary of steps in the process

1. Identify activity data on ammonia production.
2. Calculate total emissions by combining activity data, emission factors (adjusted if necessary) and any other data required.
3. Spatially and temporally disaggregate as required.

4.3.2.1.6. Comments on reliability

It is rather difficult to assess current uncertainties of emission estimates for pollutants emitted during chemical processing. The uncertainties of emission estimates can be assessed in a similar way as the uncertainties of the estimates for the fossil fuel combustion (section 4.1.1 of this document).

Emission factors in this chapter derive from the European Integrated Pollution Prevention and Control Bureau (EIPPCB)'s Best Available Technique Reference documents (BREFs). In most instances, emission factors in the BREF documents are given as ranges. The Tier 1 emission factor tables in the 2016 EMEP/EEA Air Pollutant Emission Inventory Guidebook are interpreted as a 95 % confidence interval, and when no estimate for the value is available, the geometric mean of the range has been used for the emission factor value.

Where activity data are obtained from plants, uncertainty estimates can be obtained from producers. These activity data are likely to be highly accurate (i.e. with uncertainty as low as ± 2 percent). This will include uncertainty estimates for fuel use, uncertainty estimates for ammonia production and CO₂ recovered. Data that are obtained from national statistical agencies usually do not include uncertainty estimates. It is good practice to consult with national statistical agencies to obtain information on any sampling errors. Where national statistical agencies collect data from the population of ammonia production facilities, uncertainties in national statistics are not expected to differ from uncertainties established from plant-level consultations. Where uncertainty values are not available from other sources, a default value of ± 5 percent can be used.

4.3.2.1.7. Sources of further information

Europe

- EEA (2016), EMEP/EEA Air Pollutant Emission Inventory Guidebook (European Environment Agency, Copenhagen, Denmark), 2016 Edition. <http://www.eea.europa.eu/publications/emep-eea-guidebook-2016>.

International

- IPCC (2006), 2006 Intergovernmental Panel on Climate Change Guidelines for National Greenhouse Gas Inventories Prepared by the National Greenhouse Gas Inventories Programme, Eggleston H.S., Buendia L., Miwa K., Ngara T. and Tanabe K. (eds). Published: IGES, Japan. <http://www.ipcc-nggip.iges.or.jp/public/2006gl/>.

US

- US EPA (1995-2018), Compilation of Air Pollutant Emission Factors, Volume I, Stationary Point and Area Sources, Chapter 8: Inorganic Chemical Industry, Section 8.1, Synthetic Ammonia. AP-42 (United States Environmental Protection Agency, North Carolina, US), 5th Edition. <https://www3.epa.gov/ttn/chief/ap42/ch08/final/c08s01.pdf>.

4.3.2.2. Nitric acid production

4.3.2.2.1. Nature of the source and relevant pollutants

Nitric acid production is a large-scale process that involves the catalytic oxidation of ammonia by air (oxygen) yielding nitrogen oxide then oxidised into nitrogen dioxide (NO₂) and absorbed in water. Nitrogen dioxide is first produced as described above and then absorbed in highly concentrated acid, distilled, condensed and finally converted into highly concentrated nitric acid at high pressure by adding a mixture of water and pure oxygen.

The relevant process units are the absorption tower and the tail gas cleaning units, e.g. selective catalytic or non-catalytic reduction (SCR, SNCR) for NO_x emissions. Small amounts of NO_x are also lost for acid concentrating plants. The NO_x emissions contain a mixture of NO and NO₂, dinitric oxide (N₂O₃) and dinitric tetroxide (N₂O₄). Emissions of N₂O (nitrous oxide) have to be reported separately.

Commercial production of nitric acid is a major source of atmospheric nitrous oxide (N₂O) unless steps are taken to mitigate industrial emissions of N₂O. Other significant sources of atmospheric nitrous oxide include agricultural activities, production of chemicals such as adipic acid, wastewater treatment and natural sources.

4.3.2.2.2. Factors affecting releases

Ducted emissions are the only chemical industry emissions that can be controlled. Control/abatement examples include waste gas combustion units (e.g. flares, incinerators) may produce secondary pollutants that did not exist in the original waste stream (e.g. dioxins, particulates), as well as combustion gases; stripping of wastewater (with air or steam) to transfer dissolved organics into the gaseous phase; NMVOCs from wastewater collection systems (e.g. drains, balancing tanks); NMVOCs from wastewater treatment facilities (e.g. vaporisation of NMVOCs in biological treatment units); and NMVOCs and particulates from storage and treatment of solid wastes. Certain controls may produce secondary pollutants that did not exist in the original waste stream (e.g. dioxins, particulates and combustion gases from waste incineration).

Prevention and/or minimisation through recovery and good practice are used for diffused and fugitive emissions controls. Fugitive emissions can be reduced through a Leak Detection and Repair programme (LDAR), which consists of measuring the VOC concentration in the atmosphere around the potential leaking point, then selecting equipment leaking over a defined threshold value and finally operating a repair on those leaking items. More information on abatement in the chemical industry can be found in the

BREFs on the various chemical industries, as well as a dedicated BREF document on abatement.

4.3.2.2.3. Description of release estimation techniques

The NO_x emissions from nitric acid production are estimated using the following Tier 1 equation:

$$E_{\text{pollutant}} = AR_{\text{production}} \times EF_{\text{pollutant}}$$

where:

$E_{\text{pollutant}}$ = the emission of a pollutant (kg)

$AR_{\text{production}}$ = the annual production of nitric acid

$EF_{\text{pollutant}}$ = the emission factor of the relevant pollutant

The Tier 1 equation is applied at the national level, using annual national total chemical production. Information on the production of chemical compounds, suitable for estimating emissions is widely available from United Nations statistical yearbooks or national statistics.

The Tier 1 emission factors assume an averaged or typical technology and abatement implementation in the country and integrate all sub-processes in the chemical industry between inputting raw material and the final shipment off the facilities. The emission factors, as provided in the 2016 EMEP/EEA Air Pollutant Emission Inventory Guidebook, are: 10,000 g/Mg nitric acid produced, 100 percent acid. NO_x emissions vary considerably depending on the type of control equipment and the process conditions.

When specific abatement options are to be taken into account, a Tier 1 method is not applicable and a Tier 2 or Tier 3 approach must be used.

4.3.2.2.4. Spatial allocation

Chemical production plants should be considered as point sources if emissions can be calculated from available plant-specific data. Otherwise, national emissions should be disaggregated based on plant capacity, employment or population statistics to calculate non-point source emissions.

4.3.2.2.5. Summary of steps in the process

1. Identify activity data on nitric acid production.
2. Calculate total emissions by combining activity data, emission factors (adjusted if necessary) and any other data required.
3. Spatially and temporally disaggregate as required.

4.3.2.2.6. Comments on reliability

It is rather difficult to assess current uncertainties of emission estimates for pollutants emitted during chemical processing. The uncertainties of emission estimates can be assessed in a similar way as the uncertainties of the estimates for the fossil fuel combustion (section 4.1.1 of this document).

Emission factors in this chapter derive from the EIPPCB's BREFs. In most instances, emission factors in the BREF documents are given as ranges. The Tier 1 emission factor

tables in the 2016 EMEP/EEA Air Pollutant Emission Inventory Guidebook are interpreted as a 95 % confidence interval, and when no estimate for the value is available, the geometric mean of the range has been used for the emission factor value.

Where activity data are obtained from plants, uncertainty estimates can be obtained from producers. Data that are obtained from national statistical agencies usually do not include uncertainty estimates. It is good practice to consult with national statistical agencies to obtain information on any sampling errors. Where national statistical agencies collect data from the population of nitric acid production facilities, uncertainties in national statistics are not expected to differ from uncertainties established from plant-level consultations. Where uncertainty values are not available from other sources, a default value of ± 2 percent can be used. To reduce uncertainty it is good practice to ensure that all activity data are for 100 percent HNO₃.

4.3.2.2.7. Sources of further information

Europe

- EEA (2016), EMEP/EEA Air Pollutant Emission Inventory Guidebook (European Environment Agency, Copenhagen, Denmark), 2016 Edition. <http://www.eea.europa.eu/publications/emep-eea-guidebook-2016>.

International

- IPCC (2006), 2006 Intergovernmental Panel on Climate Change Guidelines for National Greenhouse Gas Inventories Prepared by the National Greenhouse Gas Inventories Programme, Eggleston H.S., Buendia L., Miwa K., Ngara T. and Tanabe K. (eds). Published: IGES, Japan. <http://www.ipcc-nggip.iges.or.jp/public/2006gl/>.

US

- US EPA (1995-2018), Compilation of Air Pollutant Emission Factors, Volume I, Stationary Point and Area Sources, Chapter 8: Inorganic Chemical Industry, Section 8.8, Nitric Acid. AP-42 (United States Environmental Protection Agency, North Carolina, US), 5th Edition. <https://www3.epa.gov/ttn/chief/ap42/ch08/final/c08s08.pdf>.

4.3.2.3. Adipic acid production

4.3.2.3.1. Nature of the source and relevant pollutants

Adipic acid, produced from cyclohexane, is used in the production of nylon (primarily 6.6-nylon) and in the manufacturing of polyurethanes and polyester resins. Cyclohexane is used to produce KA, a mixture of cyclohexanol and cyclohexanone. KA is then oxidised with nitric acid to produce adipic acid. Adipic acid production is relevant for emissions of greenhouse gases (N₂O) but not considered significant for other air emissions included in the protocols.

4.3.2.3.2. Factors affecting releases

Ducted emissions are the only chemical industry emissions that can be controlled. Control/abatement examples include waste gas combustion units (e.g. flares, incinerators) may produce secondary pollutants that did not exist in the original waste stream (e.g. dioxins, particulates), as well as combustion gases; stripping of wastewater (with air or

steam) to transfer dissolved organics into the gaseous phase; NMVOCs from wastewater collection systems (e.g. drains, balancing tanks); NMVOCs from wastewater treatment facilities (e.g. vaporisation of NMVOCs in biological treatment units); and NMVOCs and particulates from storage and treatment of solid wastes. Certain controls may produce secondary pollutants that did not exist in the original waste stream (e.g. dioxins, particulates and combustion gases from waste incineration).

Prevention and/or minimisation through recovery and good practice are used for diffused and fugitive emissions controls. Fugitive emissions can be reduced through a Leak Detection and Repair programme (LDAR), which consists of measuring the VOC concentration in the atmosphere around the potential leaking point, then selecting equipment leaking over a defined threshold value and finally operating a repair on those leaking items. More information on abatement in the chemical industry can be found in the BREFs on the various chemical industries, as well as a dedicated BREF document on abatement.

4.3.2.3.3. Description of release estimation techniques

The NO_x and CO emissions from adipic acid production are estimated using the following Tier 1 equation:

$$E_{\text{pollutant}} = AR_{\text{production}} \times EF_{\text{pollutant}}$$

where:

$E_{\text{pollutant}}$ = the emission of a pollutant (kg)

$AR_{\text{production}}$ = the annual production of adipic acid

$EF_{\text{pollutant}}$ = the emission factor of the relevant pollutant

The Tier 1 equation is applied at the national level, using annual national total chemical production. Information on the production of chemical compounds, suitable for estimating emissions is widely available from United Nations statistical yearbooks or national statistics.

The Tier 1 emission factors assume an averaged or typical technology and abatement implementation in the country and integrate all sub-processes in the chemical industry between inputting raw material and the final shipment off the facilities. Adipic acid production is relevant for emissions of greenhouse gases (particularly N₂O) and although emission factors are provided, they are not considered significant for other air emissions included in the protocols. The emission factors, as provided in the 2016 EMEP/EEA Air Pollutant Emission Inventory Guidebook, are 8 kg/Mg for NO_x and 0.4 kg/Mg for CO.

When specific abatement options are to be taken into account, a Tier 1 method is not applicable and a Tier 2 or Tier 3 approach must be used.

4.3.2.3.4. Spatial allocation

Chemical production plants should be considered as point sources if emissions can be calculated from available plant-specific data. Otherwise, national emissions should be disaggregated based on plant capacity, employment or population statistics to calculate non-point source emissions.

4.3.2.3.5. Summary of steps in the process

1. Identify activity data on adipic acid production.
2. Calculate total emissions by combining activity data, emission factors (adjusted if necessary) and any other data required.
3. Spatially and temporally disaggregate as required.

4.3.2.3.6. Comments on reliability

It is rather difficult to assess current uncertainties of emission estimates for pollutants emitted during chemical processing. The uncertainties of emission estimates can be assessed in a similar way as the uncertainties of the estimates for the fossil fuel combustion (section 4.1.1 of this document).

Emission factors in this chapter derive from the the EIPPCB's BREFs. In most instances, emission factors in the BREF documents are given as ranges. The Tier 1 emission factor tables in the 2016 EMEP/EEA Air Pollutant Emission Inventory Guidebook are interpreted as a 95 % confidence interval, and when no estimate for the value is available, the geometric mean of the range has been used for the emission factor value.

Given the small number of adipic acid plants, the uncertainty in national production data (Tier 1) is the same as for plant level data, namely, ± 2 percent.

4.3.2.3.7. Sources of further information

Europe

- EEA (2016), EMEP/EEA Air Pollutant Emission Inventory Guidebook (European Environment Agency, Copenhagen, Denmark), 2016 Edition. <http://www.eea.europa.eu/publications/emep-eea-guidebook-2016>.

International

- IPCC (2006), 2006 Intergovernmental Panel on Climate Change Guidelines for National Greenhouse Gas Inventories Prepared by the National Greenhouse Gas Inventories Programme, Eggleston H.S., Buendia L., Miwa K., Ngara T. and Tanabe K. (eds). Published: IGES, Japan. <http://www.ipcc-nggip.iges.or.jp/public/2006gl/>.

US

- US EPA (1995-2018), Compilation of Air Pollutant Emission Factors, Volume I, Stationary Point and Area Sources, Chapter 6: Organic Chemical Process Industry, Section 6.2, Adipic Acid. AP-42 (United States Environmental Protection Agency, North Carolina, US), 5th Edition. <https://www3.epa.gov/ttn/chief/ap42/ch06/final/c06s02.pdf>

4.3.2.4. Carbide production

4.3.2.4.1. Nature of the source and relevant pollutants

Calcium carbide (CaC_2) is used in the production of acetylene, in the manufacture of cyanamide (a minor historical use), and as a reductant in electric arc steel furnaces. Calcium carbide is manufactured by heating a lime and carbon mixture up to 2100 °C in an electric arc furnace. The lime is reduced by carbon to calcium carbide and carbon monoxide. The

lime used for the reaction is usually made by calcining limestone in a kiln at the plant site. The sources of carbon for the reaction are petroleum coke, metallurgical coke, and anthracite coal.

The main emissions from the production of CaC_2 are dust. NO_x emissions arise mainly from the combustion of the CO rich furnace gas, but are to be reported under the combustion source category. Emissions of dust can be encountered at various stages over the whole production process. The main source of dust emissions is dust-laden furnace gas. Use of carbon-containing raw materials in the production processes result in emissions of CO_2 and CO. The presence of hydrogen-containing volatile compounds and sulphur (S) in the petroleum coke may cause formation and emission to the atmosphere of CH_4 and SO_2 .

4.3.2.4.2. Factors affecting releases

Ducted emissions are the only chemical industry emissions that can be controlled. Control/abatement examples include waste gas combustion units (e.g. flares, incinerators) may produce secondary pollutants that did not exist in the original waste stream (e.g. dioxins, particulates), as well as combustion gases; stripping of wastewater (with air or steam) to transfer dissolved organics into the gaseous phase; NMVOCs from wastewater collection systems (e.g. drains, balancing tanks); NMVOCs from wastewater treatment facilities (e.g. vaporisation of NMVOCs in biological treatment units); and NMVOCs and particulates from storage and treatment of solid wastes. Certain controls may produce secondary pollutants that did not exist in the original waste stream (e.g. dioxins, particulates and combustion gases from waste incineration).

Prevention and/or minimisation through recovery and good practice are used for diffused and fugitive emissions controls. Fugitive emissions can be reduced through a Leak Detection and Repair programme (LDAR), which consists of measuring the VOC concentration in the atmosphere around the potential leaking point, then selecting equipment leaking over a defined threshold value and finally operating a repair on those leaking items. More information on abatement in the chemical industry can be found in the BREFs on the various chemical industries, as well as a dedicated BREF document on abatement.

4.3.2.4.3. Description of release estimation techniques

The TSP emissions from carbide production are estimated using the following Tier 1 equation:

$$E_{\text{pollutant}} = AR_{\text{production}} \times EF_{\text{pollutant}}$$

where:

$E_{\text{pollutant}}$ = the emission of a pollutant (kg)

$AR_{\text{production}}$ = the annual production of carbide

$EF_{\text{pollutant}}$ = the emission factor of the relevant pollutant

The Tier 1 equation is applied at the national level, using annual national total chemical production. Information on the production of chemical compounds, suitable for estimating emissions is widely available from United Nations statistical yearbooks or national statistics.

The Tier 1 emission factors assume an averaged or typical technology and abatement implementation in the country and integrate all sub-processes in the chemical industry

between inputting raw material and the final shipment off the facilities. The emission factor, as provided in the 2016 EMEP/EEA Air Pollutant Emission Inventory Guidebook, is 100 g/Mg carbide produced.

When specific abatement options are to be taken into account, a Tier 1 method is not applicable and a Tier 2 or Tier 3 approach must be used.

4.3.2.4.4. Spatial allocation

Chemical production plants should be considered as point sources if emissions can be calculated from available plant-specific data. Otherwise, national emissions should be disaggregated based on plant capacity, employment or population statistics to calculate non-point source emissions.

4.3.2.4.5. Summary of steps in the process

1. Identify activity data on carbide production.
2. Calculate total emissions by combining activity data, emission factors (adjusted if necessary) and any other data required.
3. Spatially and temporally disaggregate as required

4.3.2.4.6. Comments on reliability

It is rather difficult to assess current uncertainties of emission estimates for pollutants emitted during chemical processing. The uncertainties of emission estimates can be assessed in a similar way as the uncertainties of the estimates for the fossil fuel combustion (section 4.1.1 of this document).

Emission factors in this chapter derive from the EIPPCB's BREFs. In most instances, emission factors in the BREF documents are given as ranges. The Tier 1 emission factor tables in the 2016 EMEP/EEA Air Pollutant Emission Inventory Guidebook are interpreted as a 95 % confidence interval, and when no estimate for the value is available, the geometric mean of the range has been used for the emission factor value.

Where activity data are obtained directly from plants, uncertainty estimates can be obtained from producers. This will include uncertainty estimates for petroleum coke and limestone used and for carbide production data. Data that are obtained from national statistical agencies or from industrial and trade organisations usually do not include uncertainty estimates. It is good practice to consult with national statistical agencies to obtain information on any sampling errors. Where national statistic agencies collect carbide production data from production facilities, uncertainties in national statistics are not expected to differ from uncertainties estimated from plant-level consultations. Where uncertainty values are not available from other sources, a default value of ± 5 percent can be used.

4.3.2.4.7. Sources of further information

Europe

- EEA (2016), EMEP/EEA Air Pollutant Emission Inventory Guidebook (European Environment Agency, Copenhagen, Denmark), 2016 Edition. <http://www.eea.europa.eu/publications/emep-eea-guidebook-2016>.

International

- IPCC (2006), 2006 Intergovernmental Panel on Climate Change Guidelines for National Greenhouse Gas Inventories Prepared by the National Greenhouse Gas Inventories Programme, Eggleston H.S., Buendia L., Miwa K., Ngara T. and Tanabe K. (eds). Published: IGES, Japan. <http://www.ipcc-nggip.iges.or.jp/public/2006gl/>.

4.3.2.5. Soda ash production

4.3.2.5.1. Nature of the source and relevant pollutants

Soda ash is a white crystalline solid that is used as a raw material in a variety of applications, including glass production, soaps and detergents, flue gas desulphurisation, chemicals, pulp and paper and other common consumer products.

Emissions from several pollutants can be attributed to soda ash production and consumption (including sodium carbonate, Na_2CO_3). The main pollutant is CO_2 , with an average of 200–300 kg CO_2 being vented into the atmosphere per tonne of soda ash produced. CO_2 emissions vary substantially with the manufacturing process, as there are four different processes used commercially to produce soda ash. Three of the processes are natural processes (monohydrate, sodium sesquicarbonate (Trona), and direct carbonation), while the fourth (Solvay process) is classified as a synthetic process. Calcium carbonate, limestone, is used as a source of CO_2 in the Solvay process. About 25 percent of the world production of soda ash is from natural processes while 75 percent is from synthetic processes.

During the natural soda ash production process, Trona, the principal ore from which natural soda ash is made, is calcined in a rotary kiln and chemically transformed into a crude soda ash. Both CO_2 and water are generated as by-products during this process. During the synthetic Solvay process, sodium chloride brine, limestone, metallurgical coke and ammonia are used in a series of reactions leading to the production of soda ash. The ammonia is recycled and only a small amount is lost. During the Solvay process, the CO_2 that is generated is captured, compressed, and directed to Solvay precipitating towers for consumption in a mixture of brine (aqueous NaCl) and ammonia. The CO_2 is primarily recovered and recycled for use in the carbonation stage. In theory, the CO_2 generation equals the uptake and is neutral. However, in practice, some CO_2 is emitted during production because more CO_2 is produced than is stoichiometrically required and the excess CO_2 arises from calcining the limestone with metallurgical grade coke.

Carbon monoxide is virtually inert through the process and therefore all CO must be vented to the atmosphere either at the kilns or through the carbonation tower after gas scrubbers. The amount of CO released depends on the conversion of CO into CO_2 (Boudouart reaction) during the limestone calcinations step. Emissions from dust from soda ash production are limited, but arise from handling and limestone conversion in kilns. Based on measurements made in some plants, more than 75 percent of dust emissions are relatively large particles with the contribution of PM_{10} remaining relatively low.

The emissions from black carbon are considered to be insignificant for soda ash production and not included in the inventory.

NO_x and SO_x are emitted during the oxidation of nitrogen in the kiln, but are reported under the combustion category and are not included in this section.

4.3.2.5.2. Factors affecting releases

Bag filters or wet scrubbers are often used during soda ash production, which significantly help reduce the levels of dust emitted to the atmosphere.

4.3.2.5.3. Description of release estimation techniques

The CO₂ emissions from soda ash production for natural processes are estimated using the following Tier 1 equation:

$$E_{\text{CO}_2} = \text{AD} \times \text{EF}$$

where:

E_{CO_2} = emissions of CO₂, tonnes

AD = quantity of Trona used or soda ash produced, tonnes of Trona used or tonnes natural soda ash produced

EF = emission factor per unit of Trona input or natural soda ash output, tonnes CO₂/tonne of Trona or tonnes CO₂/tonne natural soda ash produced

National level activity data of Trona consumption or natural soda ash production should be used if available. If the national level activity data are not available, it is possible to estimate it by using production capacity data. It is good practice to multiply the total national production capacity by a capacity utilisation factor of 80 percent, +/- 10 percent. If no data are available for the purity of the Trona input, it is good practice to assume it is 90 percent and adjust the emission factor accordingly.

The emission factors from soda ash production for natural processes, as provided in the 2006 Intergovernmental Panel on Climate Change Guidelines for National Greenhouse Gas Inventories, are 0.097 tonnes CO₂/tonne of Trona for Trona input and 0.138 tonnes CO₂/tonnes natural soda ash produced for soda ash output. The emission factor is derived from the stoichiometric ratio between soda ash produced and purified sodium sesquicarbonate obtained from Trona.

For the synthetic soda ash production, the estimation of CO₂ emissions should be based on an overall balance of CO₂ around the whole chemical process. A simplified version of the balance of CO₂ around the whole chemical process from a stand-alone soda ash plant may be used for inventory purposes, assuming that the CO₂ emissions result from the stoichiometric oxidation of the coke carbon. The CO₂ and ammonia emissions from the Solvay soda ash production process should be included in the industrial sector rather than the energy sector of an inventory and the coke used in the production process should be deducted from the energy sector as a non-energy use of coke.

The CO, NH₃, and TSP emissions from soda ash production are estimated using the following Tier 1 equation:

$$E_{\text{pollutant}} = \text{AR}_{\text{production}} \times \text{EF}_{\text{pollutant}}$$

where:

$E_{\text{pollutant}}$ = the emission of the specified pollutant

$\text{AR}_{\text{production}}$ = the activity rate for the soda ash production/use

$\text{EF}_{\text{pollutant}}$ = the emission factor of the relevant pollutant

The emission factors for emissions from soda ash production, as provided in the 2016 EMEP/EEA Air Pollutant Emission Inventory Guidebook, are 9 kg/Mg soda ash produced for CO, 0.9 kg/Mg soda ash produced for NH₃, and 0.1 kg/Mg soda ash produced for TSP. The Tier 1 emission factors for CO, NH₃, and TSP assume an averaged or typical technology and abatement implementation in the country and integrate all sub-processes.

4.3.2.5.4. Spatial allocation

Chemical production plants should be considered as point sources if emissions can be calculated from available plant-specific data. Otherwise, national emissions should be disaggregated based on plant capacity, employment or population statistics to calculate non-point source emissions.

4.3.2.5.5. Summary of steps in the process

1. Identify activity data on soda ash production.
2. For CO₂ emissions, determine if the soda ash production process is natural or synthetic.
3. For CO₂ emissions, if the national level activity data are not available, estimate using production capacity data and a capacity utilisation factor. If no data are available for the purity of the Trona input, assume it is 90 percent and adjust the emission factor accordingly.
4. Calculate total emissions by combining activity data, emission factors (adjusted if necessary) and any other data required.
5. Spatially and temporally disaggregate as required.

4.3.2.5.6. Comments on reliability

For the emission factors for CO₂ for natural processes of soda ash production, assuming the purity of the input or output is 100 percent, uncertainty of the default emission factor is negligible. The emission factors do not take into account fractional purities of Trona input or soda ash output, and are expected to result in consistent over-estimation of emissions.

4.3.2.5.7. Sources of further information

Europe

- EEA (2016), EMEP/EEA Air Pollutant Emission Inventory Guidebook (European Environment Agency, Copenhagen, Denmark), 2016 Edition. <http://www.eea.europa.eu/publications/emep-eea-guidebook-2016>.
- EC (2018), JRC Reference Report on Monitoring of Emissions to Air and Water from IED Installations, (European Commission, European Union, Luxembourg) <https://ec.europa.eu/jrc/en/publication/eur-scientific-and-technical-research-reports/jrc-reference-report-monitoring-emissions-air-and-water-ied-installations-industrial>.

International

- IPCC (2006), 2006 Intergovernmental Panel on Climate Change Guidelines for National Greenhouse Gas Inventories Prepared by the National Greenhouse Gas Inventories Programme, Eggleston H.S., Buendia L., Miwa K., Ngara T. and

Tanabe K. (eds). Published: IGES, Japan. <http://www.ipcc-nggip.iges.or.jp/public/2006gl/>.

US

- US EPA (1995-2018), Compilation of Air Pollutant Emission Factors, Volume I, Stationary Point and Area Sources, Chapter 8: Inorganic Chemical Industry, Section 8.12, Sodium Carbonate. AP-42 (United States Environmental Protection Agency, North Carolina, US), 5th Edition. <https://www3.epa.gov/ttn/chief/ap42/ch08/final/c08s12.pdf>

4.3.2.6. *Other chemical industry*

4.3.2.6.1. Nature of the source and relevant pollutants

The other chemical industry source category includes a large collection of different chemical production processes. A list of all the chemicals included and their SNAP codes can be found in the 2016 EMEP/EEA Air Pollutant Emission Inventory Guidebook.

Although processes differ substantially, the processes are again basically sets of unit operations as described earlier in this section. In terms of emissions, a distinction can be made between inorganic and organic processes. Emissions from inorganic processes will mostly consist of particulate matter while emissions from organic processes will mostly consist of NMVOCs.

Process descriptions for the other chemicals included in this source category can be found in the 2016 EMEP/EEA Air Pollutant Emission Inventory Guidebook. However, sulphuric acid production, which is one of the most important large-scale chemical processes, is discussed here.

The relevant process units for SO₂ emissions are the cleaning of raw gas containing SO₂ (gas pre-treatment), the catalytic oxidation to SO₃ (converter), and the final absorbing tower and scrubbers.

The commercial production of sulphuric acid includes the following steps: production of gases containing SO₂ and cleaning of the gases obtained if necessary; oxidation of SO₂ to SO₃; and absorption of the SO₃ obtained in water. Sulphuric oxides, which include SO₂ and SO₃ (reported together and expressed as SO₂), are the main relevant pollutants of sulphuric acid production. SO₂ emissions are released from the production of gases containing SO₂ (raw gas preparation), the oxidation of SO₂ to SO₃ (converter) and the absorption of SO₃ obtained (H₂SO₄ production). Nearly all sulphur dioxide emissions from sulphuric acid plants are found in the exit stack gases. In addition to these, small quantities of sulphur oxides are emitted from storage tank vents as well as from tank truck vents during loading operations, from sulphuric acid concentrators and through leaks in process equipment. Few data are available on the quantity of emissions from these non-stack sources. The emissions contain sulphur dioxide and sulphur trioxide depending on the efficiency of converting sulphur dioxide to sulphur trioxide.

Emissions of NO_x, NMVOC, CO, and NH₃ are negligible. Emissions of metals (e.g. from roasting sulphur in the smelter gas) are not relevant due to the fact that most of them are particle bound and separated by the wet gas cleaning (e.g. electrostatic precipitation). Metals remaining in the flue gas are mostly absorbed by the sulphuric acid formed in the converter.

4.3.2.6.2. Factors affecting releases

Ducted emissions are the only chemical industry emissions that can be controlled. Control/abatement examples include waste gas combustion units (e.g. flares, incinerators) that may produce secondary pollutants that did not exist in the original waste stream (e.g. dioxins, particulates), as well as combustion gases; stripping of wastewater (with air or steam) to transfer dissolved organics into the gaseous phase; NMVOCs from wastewater collection systems (e.g. drains, balancing tanks); NMVOCs from wastewater treatment facilities (e.g. vaporisation of NMVOCs in biological treatment units); and NMVOCs and particulates from storage and treatment of solid wastes.

Prevention and/or minimisation through recovery and good practice are used for diffused and fugitive emissions controls. Fugitive emissions can be reduced through a Leak Detection And Repair programme (LDAR), which consists of measuring the VOC concentration in the atmosphere around the potential leaking point, identifying the equipment leaking over a defined threshold value and finally performing a repair on those leaking items. More information on abatement in the chemical industry can be found in the BREFs on the various chemical industries, as well as a dedicated BREF document on abatement.

For sulphuric acid, scrubbers may be installed for the cleaning of raw gas and behind the tail gas cleaning. Control measures include the oxidising gas scrubbing process and the tail gas scrubbing with NH_3 .

4.3.2.6.3. Description of release estimation techniques

Emissions from inorganic processes from the chemical industry will mostly consist of particulate matter while emissions from organic processes will mostly consist of NMVOCs. The PM and NMVOC emissions from other chemical industry production are estimated using the following Tier 1 equation:

$$E_{\text{pollutant}} = AR_{\text{production}} \times EF_{\text{pollutant}}$$

where:

$E_{\text{pollutant}}$ = the emission of a pollutant (kg)

$AR_{\text{production}}$ = the annual production of other chemicals

$EF_{\text{pollutant}}$ = the emission factor of the relevant pollutant

The Tier 1 equation is applied at the national level, using annual national total chemical production. Information on the production of chemical compounds, suitable for estimating emissions is widely available from United Nations statistical yearbooks or national statistics.

The Tier 1 emission factors are derived using reported emission data in the European Pollutant Release and Transfer Register (E-PRTR) for the chemical industry and combining these with activity data from Eurostat for the EU-25. The emission factors, as provided in the 2016 EMEP/EEA Air Pollutant Emission Inventory Guidebook, are 8 kg/ton for NMVOC and 50 kg/ton for TSP.

When specific abatement options are to be taken into account, a Tier 1 method is not applicable and a Tier 2 or Tier 3 approach must be used.

4.3.2.6.4. Spatial allocation

Chemical production plants should be considered as point sources if emissions can be calculated from available plant-specific data. Otherwise, national emissions should be disaggregated based on plant capacity, employment or population statistics to calculate non-point source emissions.

4.3.2.6.5. Summary of steps in the process

1. Identify activity data on other chemical production.
2. Calculate total emissions by combining activity data, emission factors (adjusted if necessary) and any other data required.
3. Spatially and temporally disaggregate as required.

4.3.2.6.6. Comments on reliability

It is rather difficult to assess current uncertainties of emission estimates for pollutants emitted during chemical processing. The uncertainties of emission estimates can be assessed in a similar way as the uncertainties of the estimates for the fossil fuel combustion (section 4.1.1 of this document).

Emission factors in this chapter derive from the EIPPCB's BREFs. In most instances, emission factors in the BREF documents are given as ranges. The Tier 1 emission factor tables in the 2016 EMEP/EEA Air Pollutant Emission Inventory Guidebook are interpreted as a 95 % confidence interval, and when no estimate for the value is available, the geometric mean of the range has been used for the emission factor value.

There are unavoidable uncertainties associated with this approach: E-PRTR emissions have not always been properly audited and validated and significant errors in some E-PRTR data points have been noted previously; E-PRTR emissions data do not take into account emissions from facilities whose emissions are under the respective pollutant thresholds; and as E-PRTR does not provide information on activity data, those data were taken from Eurostat statistics but no exact correspondence can be established with the activity data of the corresponding E-PRTR emissions reporting facilities.

4.3.2.6.7. Sources of further information

Europe

- EEA (2016), EMEP/EEA Air Pollutant Emission Inventory Guidebook (European Environment Agency, Copenhagen, Denmark), 2016 Edition. <http://www.eea.europa.eu/publications/emep-eea-guidebook-2016>.

International

- IPCC (2006), 2006 Intergovernmental Panel on Climate Change Guidelines for National Greenhouse Gas Inventories Prepared by the National Greenhouse Gas Inventories Programme, Eggleston H.S., Buendia L., Miwa K., Ngara T. and Tanabe K. (eds). Published: IGES, Japan. <http://www.ipcc-nggip.iges.or.jp/public/2006gl/>.

US

- US EPA (1995-2018), Compilation of Air Pollutant Emission Factors, Volume I, Stationary Point and Area Sources, Chapter 8: Inorganic Chemical Industry, AP-

42 (United States Environmental Protection Agency, North Carolina, US), 5th Edition. <https://www3.epa.gov/ttn/chief/ap42/ch08/index.html>

4.3.2.7. Storage, handling, transport of chemical products

4.3.2.7.1. Nature of the source and relevant pollutants

This source category includes processes in storage and handling of inorganic chemical products (SNAP 040415) and organic chemical products (SNAP 040522). Emissions may arise from tank losses from displacement during filling and breathing during ambient temperature changes (mainly NMVOCs with rate of loss depending on vapour pressure); loading/unloading of containers and vessels (tankers for road, rail and boat); blanket gases used in storage tanks; particulate losses from conveyors; and evaporative losses from spills.

Detailed information on emission sources may be found in the EIPPCB's BREFs on emissions from storage of bulk or dangerous materials.

4.3.2.7.2. Factors affecting releases

See Section 4.3.2.6.2.

4.3.2.7.3. Description of release estimation techniques

Tier 1 emission factors and methods for estimating emissions of storage, handling and transport of chemical products are not provided since coverage of these emissions is included in the other chemical industry source categories. The default Tier 1 emission factors for the chemical industry also include storage and handling in production

4.3.2.7.4. Spatial allocation

Chemical production plants should be considered as point sources if emissions can be calculated from available plant-specific data. Otherwise, national emissions should be disaggregated based on plant capacity, employment or population statistics to calculate non-point source emissions.

4.3.2.7.5. Summary of steps in the process

1. Identify activity data on storage, handling, and transport of chemicals.
2. Calculate total emissions by combining activity data, emission factors (adjusted if necessary) and any other data required.
3. Spatially and temporally disaggregate as required.

4.3.2.7.6. Comments on reliability

It is rather difficult to assess current uncertainties of emission estimates for pollutants emitted during chemical processing. The uncertainties of emission estimates can be assessed in a similar way as the uncertainties of the estimates for the fossil fuel combustion (section 4.1.1 of this document).

4.3.2.7.7. Sources of further information

Europe

- EEA (2016), EMEP/EEA Air Pollutant Emission Inventory Guidebook (European Environment Agency, Copenhagen, Denmark), 2016 Edition. <http://www.eea.europa.eu/publications/emep-eea-guidebook-2016>.
- EC (2006), Integrated Pollution Prevention and Control Reference Document on Best Available Techniques on Emissions from Storage, (European Commission, European Union, Luxembourg), http://eippcb.jrc.ec.europa.eu/reference/BREF/esb_bref_0706.pdf

International

- IPCC (2006), 2006 Intergovernmental Panel on Climate Change Guidelines for National Greenhouse Gas Inventories Prepared by the National Greenhouse Gas Inventories Programme, Eggleston H.S., Buendia L., Miwa K., Ngara T. and Tanabe K. (eds). Published: IGES, Japan. <http://www.ipcc-nggip.iges.or.jp/public/2006gl/>.

US

- US EPA (1995-2018), Compilation of Air Pollutant Emission Factors, Volume I, Stationary Point and Area Sources, Chapter 8: Inorganic Chemical Industry, AP-42 (United States Environmental Protection Agency, North Carolina, US), 5th Edition. <https://www3.epa.gov/ttn/chief/ap42/ch08/index.html>
- US EPA (1995-2018), *Compilation of Air Pollutant Emission Factors, Volume I, Stationary Point and Area Sources, Chapter 6: Organic Chemical Process Industry, AP-42* (United States Environmental Protection Agency, North Carolina, US), 5th Edition. <https://www3.epa.gov/ttn/chief/ap42/ch06/index.html>

4.3.3. Metal production

4.3.3.1. Iron and steel production

4.3.3.1.1. Nature of the source and relevant pollutants

The iron and steel industry is a highly material and energy-intensive industry in which more than half of the mass input becomes outputs in the form of off-gases and solid wastes or by-products. The contribution of the iron and steel production sector to the total emissions in the air in the EU is considerable for a number of pollutants, especially some metals and polychlorinated dibenzo-p-dioxins and dibenzofurans (PCDD/F).

The iron and steel industry consists of primary facilities producing both iron and steel, secondary steel making facilities, iron production facilities, and offsite production of metallurgical coke. The main processes for iron and steel production include metallurgical coke, sinter, pellet, iron ore, iron, steel making, steel casting, and very often combustion of blast furnace and coke oven gases for other purposes. The main processes occur at integrated facilities and typically include blast furnaces and basic oxygen steel making furnaces. In some cases, open hearth furnaces are used. It is common for parts of the production process to take place under another operator offsite, such as an offsite coke production facility. In some countries coke production facilities can exist that are not linked to iron and steel production, i.e. offsite. This inventory methodology includes estimating emissions from all coke production to ensure consistency and completeness. Therefore, it is good practice for countries to estimate emissions from onsite and offsite coke production

separately, as the by-products of onsite coke production are often used during the production of iron and steel.

Metallurgical coke, the solid product obtained from carbonisation of coal, predominantly coking coal, at a high temperature, is primarily used in the blast furnace to make iron. Metallurgical coke can also be used in other metallurgical processes, such as the manufacture of cast iron, ferroalloys, lead and zinc, and in kilns to make lime and magnesium. Coke oven gas, which may be burned for energy recovery within the coke plant or transferred onsite in an integrated iron and steel plant and used for in sinter production or iron production processes, is a by-product of the manufacture of metallurgical coke for the production of iron and steel. CO₂ emissions from metallurgical coke production are included in the energy sector and are not process related.

Travelling grate sintering is the most important technique for iron ore sintering. The discontinuous pan sintering and rotary kiln processes are used at very few plants and not included in the 2016 EMEP/EEA Air Pollutant Emission Inventory Guidebook inventory methodology. Iron ore and other iron-containing materials, including fine iron ore, additives such as lime or olivine, and iron-bearing recycled materials from downstream iron and steel making processes, may be agglomerated in sinter plants at integrated iron and steel plants prior to introduction into the blast furnace. Coke breeze, small-grade oven coke with particle sizes of less than five millimetres, is the most commonly used process material in sinter plants and may be produced from onsite coke ovens in integrated plants or purchased from an offsite producer. Pellets formed from iron-containing raw materials at pelletisation plants, primarily located at iron mines or shipping ports, may use natural gas as a fuel or coke oven gas for plants located onsite at an integrated facility. Sinter plant operations produce NO_x, SO_x, NMVOCs, metal, polycyclic organic material (e.g. PAH and PCDD/F) emissions. The NO_x and SO_x emissions occur during the combustion process and are not included in the inventory process here. The raw materials used at sintering plants contain metals, and dust emissions are associated with black carbon and metal emissions. During the sintering process, some of the metals may be volatilized and converted into volatile compounds and can therefore be found in the flue gas. Polycyclic organic material may be formed from chlorine and precursor compounds like oily additives and can be released from the sinter machine wind box, from the sinter machine discharge point, and from sinter product processing operations (i.e. crushing, screening, and cooling). At a sinter plant, emissions may occur as direct stack emissions and to a minor degree as fugitive indirect emissions during all process steps. Indirect emissions can include emissions that arise during handling and transportation of raw materials and cooled sinter or through leakages in the roof at the end of the sinter belt due to the strong thermal convection in the sinter hall.

During the production of iron, carbon is supplied to the blast furnace mainly in the form of coke produced from metallurgical grade coking coal, though charcoal made from wood or other forms of carbon. Carbon is used as a reducing agent to convert iron oxides to iron as well as an energy source to provide heat when carbon and oxygen react exothermically. During the combustion of coke in blast furnaces, blast furnace gas is created. Blast furnace gas is typically recovered and used as a fuel within the plant and in other steel industry processes or as a fuel source for power stations; recovered and transferred to an onsite coke plant and burned for energy within coke ovens; or transferred offsite to be used as an energy source within the furnace and when blast furnace gas is combusted to heat blast air. Iron ore can also be produced through direct reduction process, in which the iron ore is reduced to metallic iron in the solid state referred to as direct reduced iron (DRI) with a carbon content of less than two percent. Iron production, using carbon to convert iron ore to iron,

is a major source of emissions of CO, CO₂, and NMVOCs. While blast furnace charging may produce dust particles from the charging of smelters, the particle size is bigger than 10 microns and is rather inert due to the extensive pre-treatment activities like pelletising and sintering. Boring of the tap and filling of the rough can produce dust emissions, with a particle size less than 10 microns, from contact between the hot metal and slag and ambient oxygen. The heating of the transport trough after coating creates volatile decomposition products (also emitted by the heating of the plugging material), which are polycyclic aromatic hydrocarbons and benzene containing aromatics. However, the amount of coal used is so small that these emissions can be neglected.

The production of steel occurs at integrated facilities from iron ore or at secondary facilities which produce steel mainly from recycled steel scrap. Most CO₂ emitted by the iron and steel industry is associated with the production of iron, more specifically the use of carbon to convert iron ore to iron. Integrated facilities can include blast furnaces, basic oxygen steel making furnaces (BOF), and occasionally open hearth furnaces (OHF). Raw steel is produced using a basic oxygen furnace from pig iron produced by the blast furnace and then processed into finished steel products or directly into iron products. Secondary steel making most often occurs in electric arc furnaces (EAF). BOFs accounted for 63 percent, EAFs accounted for 33 percent, and OHFs accounted for 4 percent of world steel production in 2003. In a BOF, steel is produced by charging the vessel with molten iron and steel scrap (70-90 percent and 10-30 percent, respectively). High purity oxygen then combines with the carbon in the iron to create an exothermic reaction that melts the charge while lowering the carbon content from three to four percent to less than one percent to produce the desired grade of steel. In an EAF, steel is produced by charging 100 percent recycled steel scrap that is melted using electrical energy imparted to the charge through carbon electrodes and then refined and alloyed to produce the desired grade of steel. Since the process of producing steel in an EAF is mainly one of melting scrap and not reducing oxides, carbon's role is not as dominant as it is in the blast furnace/BOF process. OHFs produce NO_x, CO, and SO_x emissions from combustion as particulate matter and metal process emissions. Dust generation depends on combustion, mechanical impact of furnace atmosphere and charge, and the chemical processes. During the process of intensive refining, rising CO bubbles can throw particles to the surface of the melt which are then entrained by furnace gases which increase the dust load. Introducing ore materials, dolomite and limestone into the furnace, which affects slag generation, and oxygen application for intensification of combustion and refining processes both result in higher volumes of furnace gas dust generation. BOFs produce CO, CO₂, and dust emissions (which contain a small amount of black carbon and metals). PAH containing aromatic hydrocarbons are produced when the converter provided with a fire resistant coating is preheated, but the amount of PAH is usually below the detection limit of the measuring technique. EAFs produce CO, CO₂, and dust emissions (which contain metals), with 60 percent of dust particles measuring smaller than 10 microns. EAFs also emit small amounts of black carbon, hexachlorobenzene, dioxins, and furans. PAH emissions depend on the type of coating material used and may not be emitted in every country. For example, the Netherlands uses tar-free materials for the coating and therefore PAH are not emitted. In a majority of scrap-charged EAF, CO₂ emissions are mainly associated with consumption of the carbon electrodes. All carbon used in EAFs and other steelmaking processes should be considered process-related emissions.

After the steel making process, casting products such as ingots, slabs, billets, or blooms, are processed in rolling mills and product finishing lines to prepare them for market. Hot-rolling of slabs and billets produce hydrocarbon emissions from lubricating oils. Preheating

materials and annealing after rolling as well as gradual heating and cooling result in NO_x and CO emissions. If volatile halogenated organic (VHO) gas is used, SO₂ will be emitted. During the cold rolling process, pickling beforehand results in hydrochloric acid emissions and cold rolling results in emissions of hydrocarbons and decomposition products of lubricant oil. Rolling mill emissions are small compared to the integrated steel plant and are not considered as a separate source in Tier 1 emission factors.

Part of the iron and steel production process includes combustion, mainly during sintering. The emissions from combustion are included in the inventory on combustion, not in this section.

4.3.3.1.2. Factors affecting releases

Several abatement measures to reduce dust, and the compounds bound to particulates, are put in place during the production of iron and steel.

At sinter plants, sinter strand wind box emissions are commonly controlled by cyclone cleaners followed by a dry or wet electrostatic precipitator (ESP); high-pressure drop wet scrubber or baghouse. Crusher and hot screen emissions are usually controlled by hooding and a baghouse or scrubber. Usually horizontal dry electrostatic precipitators are used. However, less efficient mechanical dust removal devices (e.g. cyclone batteries) might be installed in old sinter plants if only protection of the blower wheel rather than environmental protection is intended. While some countries only have low standard abatement technology put in place, others are equipped with more advanced technologies, including wet venturi washers. As polycyclic organic material (POM) is a relevant source of dioxins and furans, some sinter plants have been equipped with special abatement technologies (e.g. the 'airfine system' in Austria, injection of activated charcoal, open hearth coke in conjunction with a fabric filter) or optimised dust removal facilities, such as 'MEEP', which is ESP with a rotating electrode.

When using a blast furnace for pig iron production, a vapour lock is installed on the top of the smelter to reduce the escape of the basic materials during charging. The lock is charged after pressure equalization and the sealed charging system can be with or without a bell. The evacuation of gas at the top of the furnace and connection to the blast furnace gas treatment system can also be used to control emissions. The trough, the skimmer and the transport runners are usually covered. Dust and decomposition products are removed, and pass through fabric filters before emission into air. From the decomposition products of tar and coal, only the condensable part of the PAH emissions is captured by the fabric filters. The dust and decomposition products not captured pass through the roof and are not abated. The total amount escaping through the roof is about 40 percent of the total emission.

Wet scrubbers, electrostatic precipitators, or fabric filters are used for furnace gas dust removal in the case of purifying furnace gases from open-hearth furnaces, as the effectiveness of dust removal units should not be lower than 99 percent. Wet scrubbers usually consist of two elements: dust coagulator and basic dust removal unit. The dust removal systems most often used in the case of open hearth furnaces are electrostatic precipitators since their efficiency is very high and usually exceeds 99 percent. Only in a few cases, lower efficiencies (i.e. 94–98 percent) are observed, but obsolete equipment reduces cleaning efficiency to about 85 percent.

For flue gas cleaning at double-bath furnaces, both wet and dry cleaning systems are applied. Dry systems are more widely used where gases are cooled and cleaned first in the waste heat boiler and in the scrubber and then in an electrostatic precipitator. Fabric filters,

which allow an efficiency of 99 percent regardless of the dust contents in furnace gas, have recently been applied to the purification of furnace gas from open hearth furnaces. Fabric filters require an especially precise design and proper selection of technical parameters. For a basic oxygen furnace, the primary dust abatement consists of a vapour cooler for separation of coarse dust and a washer for fine dust abatement and the secondary dust abatement is usually a fabric filter. In an electric arc furnace, reduction of the emissions can be achieved by technological process changes as well as by abatement equipment. Varying the operating conditions or the design of the furnace may lead to a reduction in the amount of dust produced. The use of an after burner reduces the amount of CO emitted. The use of equipment to capture the emitted particles, e.g. fabric filter or electrostatic precipitators (ESP), reduces the amount of dust emitted. Fugitive emissions can be reduced by placing the furnace in a doghouse (a “hall”) and using abatement equipment to clean the effluent from the doghouse.

In rolling mills, hydrochloric acid from pickling is removed by a washing tower and hydrocarbon vapours from rolling are captured by lamella filters. Production gas containing PAHs can be burned in afterburners.

4.3.3.1.3. Description of release estimation techniques

The measurements from emissions from particulate matter may use techniques which give filterable, condensable, or total PM emissions and depends to a large extent on the measurement conditions.

For activities involving high temperature and semi-volatile emission components, the PM emissions may be partitioned between a solid/aerosol phase and material which is gaseous at the sampling point but which can condense in the atmosphere. Dependent on the temperature of flue gases and in sampling equipment, the portion of filterable and condensable material will vary. Filterable PM measurement methods typically filter temperatures of 70-160°C and condensable fractions can be determined by recovering condensed material from chilled impinger systems downstream of a filter. A common approach for total PM includes dilution where sampled flue or exhaust gases are mixed with ambient air (either using a dilution tunnel or dilution sampling systems) which collect the filterable and condensable components on a filter at lower temperatures (but depending on the method this can be 15-52°C). The Tier 1 PM emission factors have been reviewed to identify if the data represent filterable, total (filterable and condensable) PM, or whether the basis of the emission factor cannot be determined.

The NMVOC, TSP, PM₁₀, PM_{2.5}, BC, metals, PCB, PCDD/F, PAHs, and HCB emissions from iron and steel production at an integrated steel plant are estimated using the following Tier 1 equation:

$$E_{\text{pollutant}} = AR_{\text{production}} \times EF_{\text{pollutant}}$$

where:

$E_{\text{pollutant}}$ = the emission of the specified pollutant

$AR_{\text{production}}$ = the activity rate for the iron and steel production

$EF_{\text{pollutant}}$ = the emission factor for this pollutant

The Tier 1 emission factors assume an averaged or typical technology and abatement implementation in the country and integrate all different sub-processes occurring in an integrated steel production facility, including steel production, pig iron production, and

sinter production. In cases where these sub-processes are not together in one facility, the Tier 1 method cannot be used and it is good practice to use a Tier 2 method. In cases where specific abatement options are to be taken into account a Tier 1 method is not applicable and a Tier 2 or Tier 3 approach must be used. The emission factors, as provided in the 2016 EMEP/EEA Air Pollutant Emission Inventory Guidebook, are for all relevant pollutants in an integrated steel plant, cover all the activities occurring within the facility, and are expressed per mass of liquid steel that is shipped off the facility. To obtain the emission factors for an integrated steel facility, it is assumed that for every kilogram pig iron produced, 1.16 kilogram sinter is used and for every kilogram of steel produced, 0.94 kilogram pig iron is used. The emission factors for PM represent filterable PM emissions only. The emission factors are: NMVOC – 150 g/Mg steel; TSP – 300 g/Mg steel; PM₁₀ – 180 g/Mg steel; PM_{2.5} – 140 g/Mg steel; BC – 0.36 % of PM_{2.5}; Pb – 4.6 g/Mg steel; Cd – 0.02 g/Mg steel; Hg – 0.1 g/Mg steel; As – 0.4 g/Mg steel; Cu – 0.07 g/Mg steel; Ni – 0.14 g/Mg steel; Se – 0.02 g/Mg steel; PCB – 2.5 mg/Mg steel; Total 4 PAHs – 0.48 g/Mg steel; HCB – 0.03 mg/Mg steel.

For CO₂ emissions from the production of pig iron not processed into steel, direct reduced iron, sinter production, or pellet production, the same Tier 1 equation is used. However, each process is calculated separately, with varying CO₂ emission factors. It is preferable to estimate emissions from pig iron production that is not converted into steel separately because the emission factors for integrated iron and steel production (BOF and OHF processes) take into account emissions from both steps. It is also good practice to estimate separately the emissions from sinter production and national pellet production. Separate emission estimations for sinter production and pellet production should be used if the inventory compiler does not have detailed information about the process materials used. If the process materials are known, emissions should be calculated using the Tier 2 method.

The CO₂ emissions from iron and steel production from Basic Oxygen Furnaces (BOF), Electric Arc Furnaces (EAF), and Open Hearth Furnaces (OHF) are estimated using the following Tier 1 equation:

$$E_{\text{CO}_2 \text{ non energy}} = \text{BOF} \times EF_{\text{BOF}} + \text{EAF} \times EF_{\text{EAF}} + \text{OHF} \times EF_{\text{OHF}}$$

where:

$E_{\text{CO}_2, \text{ non-energy}}$ = emissions of CO₂ to be reported in IPPU Sector, tonnes

BOF = quantity of BOF crude steel produced, tonnes

EAF = quantity of EAF crude steel produced, tonnes

OHF = quantity of OHF crude steel produced, tonnes

The CO₂ emission factors for processes, as provided in the 2006 IPCC Guidelines for National Greenhouse Gas Inventories, are: sinter production – 0.20 tonne CO₂/tonne sinter produced; coke oven – 0.56 tonne CO₂/tonne coke produced; iron production – 1.35 tonne CO₂/tonne pig iron produced; DRI – 0.70 tonne CO₂/tonne DRI produced; pellet production – 0.03 tonne CO₂/tonne pellet produced. The CO₂ emission factors for steelmaking, as provided in the 2006 IPCC Guidelines for National Greenhouse Gas Inventories, are: BOF – 1.46 tonne CO₂/tonne of steel produced; EAF – 0.08 tonne CO₂/tonne of steel produced (does not include emissions from iron production); OHG – 1.72 tonne CO₂/tonne of steel produced; global average factor (65% BOF, 30% EAF, 5% OHF) – 1.06 tonne CO₂/tonne of steel produced.

The equations all use national level annual total production data, which is widely available from the United Nations statistical yearbooks or national statistics. The amount of steel produced in the country by process type, the total amount of pig iron produced that is not processed into steel, and the total amount of coke, direct reduced iron, pellets, and sinter produced. In this case, the total amount of coke produced is assumed to be produced in integrated coke production facilities. Data may be available from governmental agencies responsible for publishing statistics, business or industry trade associations, or individual iron and steel companies. If a country only has aggregate data available, a weighted factor should be used. Total crude steel production is defined as the total output of usable ingots, continuously-cast semi-finished products, and liquid steel for castings.

4.3.3.1.4. Spatial allocation

Iron and steel production plants should be considered as point sources if emissions can be calculated from available plant-specific data. Otherwise, national emissions should be disaggregated based on plant capacity, employment or population statistics to calculate non-point source emissions.

4.3.3.1.5. Summary of steps in the process

1. Identify activity data on iron and steel production for the various processes. If only aggregate national data are available, a weighted factor should be applied.
2. Calculate total emissions by combining activity data, emission factors (adjusted if necessary) and any other data required.
3. Spatially and temporally disaggregate as required.

4.3.3.1.6. Comments on reliability

For CO₂ emission estimations, the Tier 1 method is based on national production data and default emission factors. It may lead to errors due to its reliance on assumptions rather than actual data for the quantity of inputs into the sinter production and iron and steel production sector that contribute to CO₂ emissions. Therefore, the Tier 1 is appropriate only if iron and steel production is not a key category.

4.3.3.1.7. Sources of further information

Europe

- EEA (2016), EMEP/EEA Air Pollutant Emission Inventory Guidebook (European Environment Agency, Copenhagen, Denmark), 2016 Edition. <http://www.eea.europa.eu/publications/emep-eea-guidebook-2016>.

International

- IPCC (2006), 2006 Intergovernmental Panel on Climate Change Guidelines for National Greenhouse Gas Inventories Prepared by the National Greenhouse Gas Inventories Programme, Eggleston H.S., Buendia L., Miwa K., Ngara T. and Tanabe K. (eds). Published: IGES, Japan. <http://www.ipcc-nggip.iges.or.jp/public/2006gl/>.

US

- US EPA (1995-2018), Compilation of Air Pollutant Emission Factors, Volume I, Stationary Point and Area Sources, Chapter 12: Metallurgical Industry, Section

12.5, Iron and Steel Production. AP-42 (United States Environmental Protection Agency, North Carolina, US), 5th Edition. <https://www3.epa.gov/ttn/chief/ap42/ch12/final/c12s05.pdf>.

4.3.3.2. *Ferrous alloys production*

4.3.3.2.1. Nature of the source and relevant pollutants

Ferrous alloys are master alloys containing iron and one or more non-ferrous metals as alloying elements. The principal ferrous alloys are those of chromium, manganese, and silicon. Chromium provides corrosion resistance to stainless steels. Manganese is essential to counteract the harmful effects of sulphur in the production of virtually all steels and cast iron. Silicon is used primarily for deoxidation in steel and as an alloying agent in cast iron. Boron, cobalt, columbium, copper, molybdenum, nickel, phosphorus, titanium, tungsten, vanadium, zirconium, and the rare earths impart specific characteristics and are usually added as ferrous alloys. Ferrous alloys are usually classified in two groups: bulk ferrous alloys (produced in large quantities in electric arc furnaces) and special ferrous alloys (produced in smaller quantities, but with growing importance). Bulk ferrous alloys are used in steel making and steel or iron foundries exclusively, while the use of special ferrous alloys is far more varied. In total, 86.7 percent of the ferrous alloys produced are used in the steel industry. Ferrous alloy production involves the use of electric arc furnaces and reaction crucibles into which natural products (quartz, lime, various ores, wood etc.) with relatively fluctuating physical compositions are loaded.

Ferrous alloy production can take place as a primary or secondary process, depending on the raw material used (primary or secondary raw material). The primary process can be either carbo-thermic or metallo-thermic reduction of oxidic ores or concentrates. In the carbo-thermic reduction, carbon in the form of metallurgical coke, coal, or charcoal is used as the reducing agent. When a blast furnace is used, coke is also needed as an energy source. Therefore, the process scheme contains a fuel input and combustion emissions output. Metallo-thermic reduction is mainly carried out with either silicon or aluminium as the reducing agent.

The main emissions from producing ferrous alloys are the emission of dust and fumes from the smelting processes. Dust emissions can occur from storage, handling, and pre-treatment of raw materials where fugitive dust emissions play an important role.

Part of the metals carried into the process as trace elements in the raw material will escape as metal vapour. This process depends heavily on the type of ferrous alloy produced and the temperature of the smelting process.

The emissions from the production of ferrous alloys are not considered significant, since the contribution to the total national emissions is thought to be insignificant, i.e. less than 1 percent of the national emissions of any pollutant.

Primary emissions in covered arc furnaces consist almost entirely of CO as opposed to CO₂, due to the strong reducing environment. This CO is either utilised for energy production in boilers, or it is flared. The energy produced is assumed to be used internally at the site and the carbon content of the CO subsequently converted to CO₂ in-plant. The CO gas produced in open or semi-closed furnaces is burnt to CO₂ above the charge level. Any CO emitted to the atmosphere is assumed to be converted to CO₂ within days afterwards.

Other emissions from SO₂, NO_x, CO, CO₂, PAHs, VOCs, and volatile metals can occur depending on the raw material and the process used. Emissions from ferrous alloy production,

as discussed here, only consider particulate matter and CO₂. The emissions from the other pollutants are mainly from the combustion of fuel. Therefore, these emissions are included in the stationary combustion emissions.

4.3.3.2.2. Factors affecting releases

In an open electric arc furnace, virtually all carbon monoxide and much of the organic matter burns with induced air at the furnace top. The remaining fume, captured by hooding about 1 meter above the furnace, is directed to a gas cleaning device. Fabric filters are used to control emissions from 85 percent of the open furnaces in the US. Scrubbers are used on 13 percent of the furnaces, and electrostatic precipitators on 2 percent. Two emission capture systems, not usually connected to the same gas cleaning device, are necessary for covered furnaces. A primary capture system withdraws gases from beneath the furnace cover. A secondary system captures fumes released around the electrode seals and during tapping. Scrubbers are used almost exclusively to control exhaust gases from sealed furnaces. The scrubbers capture a substantial percentage of the organic emissions, which are much greater for covered furnaces than open furnaces. The gas from sealed and mix-sealed furnaces is usually flared at the exhaust of the scrubber. The carbon monoxide-rich gas is sometimes used as a fuel in kilns and sintering machines. The efficiency of flares for the control of carbon monoxide and the reduction of VOCs has been estimated to be greater than 98 percent. A gas heating reduction of organic and carbon monoxide emissions is 98 percent efficient.

4.3.3.2.3. Description of release estimation techniques

The measurements of emissions of particulate matter from ferroalloys production above may use techniques which give filterable, condensable, or total PM and depends to a large extent on the measurement conditions.

For activities involving high temperature and semi-volatile emission components, the PM emission may be partitioned between a solid/aerosol phase and material which is gaseous at the sampling point but which can condense in the atmosphere. Dependent on the temperature of flue gases and in sampling equipment, the portion of filterable and condensable material will vary. Filterable PM measurement methods typically filter temperatures of 70-160°C and condensable fractions can be determined by recovering condensed material from chilled impinger systems downstream of a filter. A common approach for total PM includes dilution where sampled flue or exhaust gases are mixed with ambient air (either using a dilution tunnel or dilution sampling systems) which collect the filterable and condensable components on a filter at lower temperatures (but depending on the method this can be 15-52°C). The Tier 1 PM emission factors have been reviewed to identify if the data represent filterable, total (filterable and condensable) PM, or whether the basis of the emission factor cannot be determined.

The TSP, PM₁₀, PM_{2.5}, and BC emissions from ferroalloys production are estimated using the following Tier 1 equation:

$$E_{\text{pollutant}} = AR_{\text{production}} \times EF_{\text{pollutant}}$$

where:

$E_{\text{pollutant}}$ = the emission of the specified pollutant

$AR_{\text{production}}$ = the activity rate for ferroalloys production

$EF_{\text{pollutant}}$ = the emission factor for this pollutant

The emission equation assumes an average or typical technology and abatement implementation in the country and integrates all the different sub-processes. Activity data on the production of ferroalloy is available from the United Nations statistical yearbooks or national statistics.

The emission factors represent primary emissions from activities and not formation of secondary aerosol from chemical reaction in the atmosphere after release. The PM emission factors represent filterable PM emissions only, excluding any condensable fraction. The emission factors, as provided in the 2016 EMEP/EEA Air Pollutant Emission Inventory Guidebook, are: 1,000 g/Mg alloy produced for TSP, 850 g/Mg alloy produced from PM₁₀, 600 g/Mg alloy produced for PM_{2.5}, and 10 percent of PM_{2.5} for BC.

The CO₂ emissions from ferroalloys production are estimated using the following Tier 1 equation: $E_{CO_2} = \sum_i (MP_i \times EF_i)$

where:

E_{CO_2} = CO₂ emissions, tonnes

MP_i = production of ferroalloy type i , tonnes

EF_i = generic emission factor for ferroalloy type i , tonnes CO₂/tonne specific ferroalloy product

Due to the widely disparate factors depending on the type of ferroalloy production, it is necessary to determine how much tonnage is produced by which method and then to sum the product of the factors. The emission factors for CO₂, as provided in the 2006 IPCC Guidelines for National Greenhouse Gas Inventories, by type of ferroalloy are: 2.5 tonnes CO₂/tonne product for Ferrosilicon 45% Si; 3.6 tonnes CO₂/tonne product for Ferrosilicon 65 % Si; 4 tonnes CO₂/tonne product for Ferrosilicon 75% Si; 4.8 tonnes CO₂/tonne product for Ferrosilicon 90% Si; 1.3 tonnes CO₂/tonne product for Ferromanganeses (7% C); 1.5 tonnes CO₂/tonne product for Ferromanganeses (1% C); 1.4 tonnes CO₂/tonne product for Silicomanganese; 5 tonnes CO₂/tonne product for Silicon metal; and 1.3 (1.6 with sinter plant) tonnes CO₂/tonne product for Ferrochromium. For Ferromanganeses alloys the emission factors are based on production where the manganese containing raw materials are a mixture of oxide ores, carbonate ores, and imported Mn-sinter. If the sinter is produced abroad, it will not give any contribution to the national greenhouse gas inventory as emissions from sinter production must be reported where the production is located. The emission factor for Ferrosilicon 90% Si and Silicon metal is based on a Fix carbon (C) consumption of 110 percent of the stoichiometric amount needed for reduction of SiO₂. For the other Ferrosilicon -alloys the factor is based on 114 percent of the stoichiometric amount of Fix C.

The activity data for the CO₂ emissions calculation requires the amount of ferroalloy produced in the country by product type. These data are available from governmental agencies responsible for manufacturing statistics, business or industry trade associations, or individual ferroalloy companies.

4.3.3.2.4. Spatial allocation

Ferroalloy production plants should be considered as point sources if emissions can be calculated from available plant-specific data. Otherwise, national emissions should be disaggregated based on plant capacity, employment or population statistics to calculate non-point source emissions.

4.3.3.2.5. Summary of steps in the process

1. Identify activity data on ferroalloy production for the various product types.
2. Calculate total emissions by combining activity data, emission factors (adjusted if necessary) and any other data required.
3. Spatially and temporally disaggregate as required.

4.3.3.2.6. Comments on reliability

Uncertainties for ferroalloy production result predominantly from uncertainties associated with activity data, and to a lesser extent from uncertainty related to the emission factor. National statistics data on the production of ferroalloy likely have an uncertainty less than five percent. The default emission factors used in Tier 1 may have an uncertainty of 25 to 50 percent. The Tier 1 CO₂ method is very simple and may lead to errors due to its reliance on assumptions rather than actual data. Therefore, it is appropriate only when ferroalloy production is not a key category.

Emissions from ferroalloys produced with coking coal or graphite inputs would be counted in national trends, but may generate differing amounts of CO₂ per unit of ferroalloy produced compared to the use of petroleum coke.

4.3.3.2.7. Sources of further information

Europe

- EEA (2016), EMEP/EEA Air Pollutant Emission Inventory Guidebook (European Environment Agency, Copenhagen, Denmark), 2016 Edition. <http://www.eea.europa.eu/publications/emep-eea-guidebook-2016>.

International

- IPCC (2006), 2006 Intergovernmental Panel on Climate Change Guidelines for National Greenhouse Gas Inventories Prepared by the National Greenhouse Gas Inventories Programme, Eggleston H.S., Buendia L., Miwa K., Ngara T. and Tanabe K. (eds). Published: IGES, Japan. <http://www.ipcc-nggip.iges.or.jp/public/2006gl/>.

US

- US EPA (1995-2018), Compilation of Air Pollutant Emission Factors, Volume I, Stationary Point and Area Sources, Chapter 12: Metallurgical Industry, *Section 12.4, Ferroalloy Production*. AP-42 (United States Environmental Protection Agency, North Carolina, US), 5th Edition. <https://www3.epa.gov/ttn/chief/ap42/ch12/final/c12s04.pdf>.

4.3.3.3. Aluminium production

4.3.3.3.1. Nature of the source and relevant pollutants

Primary aluminium refers to aluminium produced directly from mined ore. The ore is refined and electrolytically reduced to elemental aluminium. Primary aluminium production includes the production of alumina from bauxite through the “Bayer process;” the production of aluminium by the electrolytic reduction of alumina (Al₂O₃) dissolved in a molten bath of mainly sodium aluminium fluoride (cryolite) at a temperature of

approximately 960 °C; the refinement of metal to remove impurities such as sodium, calcium oxide particles, and hydrogen through the injection of a gas into the molten metal usually in an in-line reactor; and casting slabs, T-bars, or billets in vertical direct chill casting machines that use water-cooled metal moulds, static or continuously moving metal moulds, continuous casting of thin sheets, and continuous casting of wire rod.

Secondary aluminium production covers the whole process starting from the melting of scrap. During secondary aluminium production, combustion activities also cause emissions but these emissions are covered in the stationary combustion section of the document. A secondary aluminium smelter is defined as any plant or factory in which aluminium-bearing scrap or aluminium-bearing materials, other than aluminium-bearing concentrates (ores) derived from a mining operation, are processed into aluminium alloys for industrial castings and ingots. Secondary aluminium production uses an induction, rotary, tilting, or horizontal furnace during the production process.

Detailed information of the primary and secondary production process of aluminium and the various techniques used during production can be found in Chapter 2.C.3 of the 2016 EMEP/EEA Air Pollutant Emission Inventory Guidebook.

The most important pollutants emitted from the primary aluminium electrolysis process are SO₂, CO, PAHs, and the greenhouse gas CO₂. Polyfluorinated hydrocarbons and fluorides are also produced during the electrolysis process. Dust is emitted mainly during the electrolysis stage in the primary production of aluminium. Significant fuel related emissions of SO₂ may occur during alumina production due to the use of high sulphur fuels; however, these combustion emissions should be included in the stationary combustion section and are not included in this section

The main emission during the electrolysis process in primary aluminium production is CO₂, which is an integral part of the process. The main fluoride pollutants are gaseous HF, aluminium fluoride and cryolite and are formed by the reaction of aluminium fluoride and cryolite with hydrogen during the electrolysis process. Perfluorocarbons (PFCs) are formed as a result of anode effects. Tetra-fluoro methane (CF₄) and hexa-fluoro ethane (C₂F₆) are emitted in the ratio 10:1 and cannot be removed from the gas stream with existing technology once they are formed. PAHs are emitted during the anode production. Emissions of PAHs during the electrolysis process are negligible for pre-bake plants but for Söderberg plants in which the anode is self-baked in situ, emissions do occur. Dust is emitted during electrolysis as alumina and cryolite. Casting may also be a source of dust emissions. PAHs emissions are partly in solid form at ambient temperature.

During melting, there are potential emissions to air of dust and smoke, metal compounds, chlorides, hydrogen chloride (HCl) and products of poor combustion such as dioxins and other organic compounds from the melting of primary and secondary aluminium, as well as from treatment furnaces. The formation of dioxins in the combustion zone and in the cooling part of the off-gas treatment system (de-novo synthesis) may be possible. The emissions can escape the process either as stack emissions or as fugitive emissions depending on the age of the plant and the technology used. Stack emissions are normally monitored continuously or periodically and reported by on-site staff or off-site consultants to the competent authorities.

Most CO₂ emissions result from the electrolysis reaction of the carbon anode with alumina. The consumption of prebaked carbon anodes and Söderberg paste is the principal source of process related carbon dioxide emissions from primary aluminium production. Other sources of process related carbon dioxide emissions associated with Prebake anode baking

account for less than 10 percent of the total non-energy related carbon dioxide emissions. The reactions leading to carbon dioxide emissions are well understood and the emissions are very directly connected to the tonnes of aluminium produced through the fundamental electrochemical equations for alumina reduction at a carbon anode and oxidation from thermal processes.

4.3.3.3.2. Factors affecting releases

Emission controls for primary aluminium production include dry scrubbing using alumina as an absorbent for HF removal, followed by fabric filters. The alumina absorbent is later used in the pots and the fugitive emissions from the pot room, particularly at older plants, can be significant. A few older smelters have ventilation air scrubbing systems with seawater for the ventilation air, capturing the fugitive emissions (today only one smelter (Søderberg) has ventilation air scrubbing). Modern plants rely on better hooding of the pots to reduce fugitive emissions. Some smelters also have water-scrubbing systems after the dry scrubbing for SO₂ removal.

Emission controls for secondary aluminium production include effective dust collecting arrangements for dust from both primary exhaust gases and fugitive dust emissions. Fabric filters can be used reducing the dust emissions to below 10 mg/m³. Fume extraction is an important element in secondary aluminium production as dust and smoke can be formed from contaminants on the feed as well as from the combustion and melting stages. The presence of several possible emission points on a furnace is also significant, and the collection of the emissions from such points needs to be addressed. In addition, various systems may be employed to reduce fugitive emissions during the charging phase of the process. For example, docking cars that seal against the charging door can be used to prevent emissions during charging. The other important factor is the combustion of organic coatings in the pre-treatment or melting furnace and the extraction and abatement systems can all be designed to cope with the treatment of these emissions. Fugitive emissions can be significant unless the fume collection systems are well designed. Afterburners are used generally to convert unburned VOC to CO₂ and H₂O.

4.3.3.3.3. Description of release estimation techniques

The measurements of emissions of particulate matter from aluminium production may use techniques which give filterable, condensable, or total PM and depends to a large extent on the measurement conditions.

For activities involving high temperature and semi-volatile emission components, the PM emission may be partitioned between a solid/aerosol phase and material which is gaseous at the sampling point but which can condense in the atmosphere. Dependent on the temperature of flue gases and in sampling equipment, the portion of filterable and condensable material will vary. Filterable PM measurement methods typically filter temperatures of 70-160°C and condensable fractions can be determined by recovering condensed material from chilled impinger systems downstream of a filter. A common approach for total PM includes dilution where sampled flue or exhaust gases are mixed with ambient air (either using a dilution tunnel or dilution sampling systems) which collect the filterable and condensable components on a filter at lower temperatures (but depending on the method this can be 15-52°C).

The NO_x, CO, SO_x, TSP, PM₁₀, PM_{2.5}, BC, Benzo(a)pyrene, Benzo(b)fluoranthene, and Indeno(1,2,3-cd)pyrene emissions from aluminium production are estimated using the following Tier 1 equation:

$$E_{\text{pollutant}} = AR_{\text{production}} \times EF_{\text{pollutant}}$$

where:

$E_{\text{pollutant}}$ = the emission of the specified pollutant

$AR_{\text{production}}$ = the activity rate for aluminium production

$EF_{\text{pollutant}}$ = the emission factor for this pollutant

The emission equation assumes an average or typical technology and abatement implementation in the country and integrates all the different sub-processes. Activity data on the production of aluminium is available from the United Nations statistical yearbooks or national statistics.

The PM emission factors represent filterable PM emissions only, excluding any condensable fraction and the PAH emissions occur mainly at Söderberg cell facilities (for other types of facilities, PAH emissions are substantially lower). The emission factors, as provided in the 2016 EMEP/EEA Air Pollutant Emission Inventory Guidebook, are: 1 kg/Mg aluminium for NO_x; 120 kg/Mg aluminium for CO; 4.5 kg/Mg aluminium for SO_x; 0.9 kg/Mg aluminium for TSP; 0.7 kg/Mg aluminium for PM₁₀; 0.6 kg/Mg aluminium for PM 2.5; 2.3 % of PM_{2.5} for BC; 9 g/Mg aluminium for Benzo(a)pyrene; 9 g/Mg aluminium for Benzo(b)fluoranthene; 9 g/Mg aluminium for Benzo(k)fluoranthene; and 1.1 g/Mg aluminium for Indeno(1,2,3- cd)pyrene.

For secondary aluminium production, it is advised to use the Tier 2 methodology, which is available in the EEA guidebook.

The CO₂ emissions from aluminium production are estimated using the following Tier 1 equation:

$$E_{\text{CO}_2} = EF_P \times MP_P + EF_S \times MP_S$$

where:

E_{CO_2} = CO₂ emissions from anode and/or paste consumption, tonnes

CO₂ EF_P = Prebake technology specific emission factor (tonnes CO₂/tonne aluminium produced)

MP_P = metal production from Prebake process (tonnes Al)

EF_S = Söderberg technology specific emission factor (tonnes CO₂/tonne aluminium produced)

MP_S = metal production from Söderberg process (tonnes Al)

For the CO₂ emissions calculation, production data require technology differentiation as Söderberg or Prebake. There is no need for further differentiation as to the specific type of Söderberg or Prebake technology. Production statistics should be available from every facility to enable use of Tier 1 methods for CO₂.

The default emission factors for CO₂, as provided in the 2006 IPCC Guidelines for National Greenhouse Gas Inventories, are: 1.6 tonnes CO₂/tonne Al for Prebake and 1.7 tonnes CO₂/tonne Al for Söderberg.

4.3.3.3.4. Spatial allocation

Aluminium production plants should be considered as point sources if emissions can be calculated from available plant-specific data. Otherwise, national emissions should be disaggregated based on plant capacity, employment or population statistics to calculate non-point source emissions.

4.3.3.3.5. Summary of steps in the process

Identify activity data on aluminium production. When estimating CO₂ emissions, identify production from Prebake and the Söderberg process.

Calculate total emissions by combining activity data, emission factors (adjusted if necessary) and any other data required.

Spatially and temporally disaggregate as required.

4.3.3.3.6. Comments on reliability

There is very little uncertainty in the data for the annual production of aluminium, less than 1 percent. The uncertainty in the emission factors for calculating carbon dioxide emissions from carbon anode or paste consumption should be less than less than ± 10 percent for the Tier 1 method. The main source of uncertainty is in the net carbon consumed for Prebake technologies and paste consumption for Söderberg cells. These factors are both carefully monitored and are important factors in the economic performance of a facility. Improvements in accuracy of carbon dioxide emissions inventories can be achieved by moving from Tier 1 to Tier 2 methods because there is a range of performance of reduction facilities in the consumption of carbon anode materials. Information about Tier 2 methods can be found in the 2006 IPCC Guidelines for National Greenhouse Gas Inventories.

4.3.3.3.7. Sources of further information

Europe

- EEA (2016), EMEP/EEA Air Pollutant Emission Inventory Guidebook (European Environment Agency, Copenhagen, Denmark), 2016 Edition. <http://www.eea.europa.eu/publications/emep-eea-guidebook-2016>.

International

- IPCC (2006), 2006 Intergovernmental Panel on Climate Change Guidelines for National Greenhouse Gas Inventories Prepared by the National Greenhouse Gas Inventories Programme, Eggleston H.S., Buendia L., Miwa K., Ngara T. and Tanabe K. (eds). Published: IGES, Japan. <http://www.ipcc-nggip.iges.or.jp/public/2006gl/>.

US

- US EPA (1995-2018), Compilation of Air Pollutant Emission Factors, Volume I, Stationary Point and Area Sources, Chapter 12: Metallurgical Industry, Section 12.1, Primary Aluminum Production. AP-42 (United States Environmental Protection Agency, North Carolina, US), 5th Edition. <https://www3.epa.gov/ttn/chief/ap42/ch12/final/c12s01.pdf>.

4.3.3.4. Lead production

4.3.3.4.1. Nature of the source and relevant pollutants

Primary lead production includes two pyrometallurgical processes available for the production of lead from lead sulphide or mixed lead and zinc sulphide concentrates: sintering/smelting in a blast furnace or Imperial Smelting Furnace (ISF) and direct smelting. The last primary sinter and shaft furnace operating in the EU-28 switched over to the direct smelting process in October 2013. All smelting processes may also be used for concentrates mixed with secondary raw materials. In the sintering process, fine particles of metal ores are agglomerated into nodules, briquettes, sinter, or pellets, as discussed further in the Iron and Steel Production section. Dust emissions result from handling and stockpiling of raw materials or intermediate products. In all direct smelting processes, concentrates alone or together with secondary material are mixed with other smelting additives and fluxes to produce a fairly constant feed. In all furnaces, the lead sulphide concentrates and secondary materials mix is charged directly to a furnace, then melted and oxidised. SO_x is formed and is collected, cleaned and converted to sulphuric acid. Carbon (coke or gas) and fluxing agents are added to the molten charge. The refining process is mainly directed at the removal of copper, silver, bismuth, antimony, arsenic, tin, and other impurities. There are two methods of refining crude lead: electrolytic refining and pyrometallurgical refining, though electrolytic refining is not used by plants in the EU-28. Pyrometallurgical refinery consists of a series of kettles, which are indirectly heated by oil or gas. Dust emissions mainly occur at the treatment of the different by-product streams. After refining, the lead may be alloyed and cast to market qualities.

A secondary lead smelter is defined as any plant or factory, in which lead-bearing scrap or lead-bearing materials, other than lead-bearing concentrates (ores) derived from a mining operation, are processed by metallurgical or chemical methods into refined lead, lead alloys or lead oxide. The high proportion of scrap acid batteries that is reprocessed provides feed for the alloy lead market. Secondary lead production can be produced using pyrometallurgical or hydrometallurgical processes. In contrast to secondary zinc and copper production, which use a great variety of secondary materials, the recycling of secondary lead materials is concentrated on the processing of scrap batteries, which accounts for about 80 % of secondary lead recycling globally. In general, the production of secondary lead from battery scrap is either based on breaking up and dismantling old batteries, and separating the paste, metals and organic substances or by the direct treatment of complete and non-dismantled batteries with or without sulphuric acid inside in various smelting furnaces.

The main emissions to air from primary lead and tin production are SO₂, NO_x and other nitrogen compounds, metals and their compounds, dust, and occasionally NMVOC and PCDD/F. Emissions are to a large extent bound to dust. SO_x emissions are the diffuse emissions from the oxidation stages, direct emissions from the sulphuric acid plant and the emissions of residual sulphur in the furnace charge. NO_x emissions occur from the smelting stages of production.

Dust carry-over from the smelting processes is a potential source of direct and diffuse emissions of dust and metals. Emissions of aerosols also take place in the cell room and battery breakers and may contain metals. The main sources of diffuse emissions are material storage and handling, dust sticking to vehicles or streets, and open working areas or areas where no abatement is performed. Organic carbon compounds and CO can be

emitted from the drying stage depending on the raw materials and the fuel used for drying as well as during the smelting process reduction step.

Emissions from secondary lead production include various direct and fugitive metal emissions from battery scrap preparation, the smelting process, refining and alloying, and stockpiling, transferring, charging, and discharging processes. SO_x and NO_x are emitted during secondary lead production from smelting furnaces. The amount of SO_x formed is mainly determined by the amount of sulphur contained in the raw materials and in the fuel used. Although a major part of the sulphur remains in the slag formed during the smelting process, some can be converted to SO_x. The formation of polychlorinated dioxins and furans depends on a number of factors such as scrap composition, process type and temperature.

The smelting process occurs in either a traditional blast furnace or an Imperial Smelting Furnace, and it is the reduction of the lead oxide during this process that produces CO₂ emissions. A number of reducing agents, which include coal, metallurgical coke, and natural gas, are used in the direct smelting process in different quantities for each furnace, which results in different levels of CO₂ emissions for each type of furnace. As with the furnaces used for primary lead bullion production, furnaces used in secondary lead production generate different levels of CO₂ emissions from their use of differing types and quantities of reductants.

More information on primary and secondary lead production techniques can be found in Chapter 2.C.5 of the 2016 EMEP/EEA Air Pollutant Emission Inventory Guidebook.

4.3.3.4.2. Factors affecting releases

In primary lead production, abatement methods for the sintering process are the use of bag filters, wet scrubbers or electrofilters. Dust abatement for direct smelting can be provided by bag filters or electrofilters. Improved abatement is encapsulation or evacuation of the process. An afterburner is the most common technique used to abate CO emissions from the smelting process.

Emissions containing SO_x are often used as input for sulphuric acid plants. Here, emissions from combustion and from other process steps are reconciled. Some wet sulphuric acid plants are designed to capture and convert incoming SO_x in the smelting stage with an efficiency of at least 99.8 %, resulting in an SO_x emission level from the tail gas scrubber of no more than 400 mg/Nm³. Primary measures for the control of SO_x aim to reduce the sulphur content in the fuel and in the raw materials used. Within blast furnace operation, the use of coke with low sulphur content reduces emissions.

Most secondary lead smelters are equipped with dust removing installations, such as cyclones in combination with baghouses for the control of direct emissions. The control efficiency of these installations is often very high and can reach 99.9 percent. In secondary lead production for most processes, it is possible to carry out final dust removal with fabric filters. For covering direct emissions from the refining and alloying kettles, primary suction hoods are arranged above the refining and melting kettles.

Electrostatic precipitators or wet scrubbers may be in use for special raw gas conditions. Wet scrubbers are sometimes in place for the control of SO_x. Fugitive particulate emissions can be collected by local systems like hoods and other suction facilities or by partial or complete enclosures. Oxy-fuel burners have been used in short rotary furnaces resulting in a significant reduction of the fuel input. SO_x emissions from secondary smelters can be reduced by the addition of iron and/or soda. Iron added to the furnace reacts with sulphur

contained in the feed material to form a matte (for example, iron sulphide), thus capturing the sulphur and preventing SO_x emissions. The capture rate by producing matte is approximately 90 percent under optimal conditions.

SO_x emissions originate from both the combustion of fuels and the melting of lead sulphide concentrates and are therefore discussed in both this section and the stationary combustion section. Emissions from NO_x and CO originate from combustion and are not included here.

4.3.3.4.3. Description of release estimation techniques

The measurements of emissions of particulate matter from lead production above may use techniques which give filterable, condensable, or total PM and depends to a large extent on the measurement conditions.

For activities involving high temperature and semi-volatile emission components, the PM emission may be partitioned between a solid/aerosol phase and material which is gaseous at the sampling point but which can condense in the atmosphere. Dependent on the temperature of flue gases and in sampling equipment, the portion of filterable and condensable material will vary. Filterable PM measurement methods typically filter temperatures of 70-160°C and condensable fractions can be determined by recovering condensed material from chilled impinger systems downstream of a filter. A common approach for total PM includes dilution where sampled flue or exhaust gases are mixed with ambient air (either using a dilution tunnel or dilution sampling systems) which collect the filterable and condensable components on a filter at lower temperatures (but depending on the method this can be 15-52°C). The Tier 1 PM emission factors have been reviewed to identify if the data represent filterable, total (filterable and condensable) PM, or whether the basis of the emission factor cannot be determined. The PM emission factors represent primary emissions from the activities and not formation of secondary aerosol from chemical reaction in the atmosphere after release.

The TSP, PM₁₀, PM_{2.5}, SO_x, Pb, Cd, Hg, As, Zn, PCB, and PCDD/F emissions from lead production are estimated using the following Tier 1 equation:

$$E_{\text{pollutant}} = AR_{\text{production}} \times EF_{\text{pollutant}}$$

where:

$E_{\text{pollutant}}$ = the emission of the specified pollutant

$AR_{\text{production}}$ = the activity rate for lead production

$EF_{\text{pollutant}}$ = the emission factor for this pollutant

The emission equation assumes an average or typical technology and abatement implementation in the country and integrates all the different sub-processes. Activity data on the production of lead is available from the United Nations statistical yearbooks or national statistics.

The PM emission factors represent filterable PM emissions only, excluding any condensable fraction. The emission factors, as provided in the 2016 EMEP/EEA Air Pollutant Emission Inventory Guidebook, are: 6 g/Mg lead for TSP; 5 g/Mg lead for PM₁₀; 2.5 g/Mg lead for PM_{2.5}; 2050 g/Mg lead for SO_x; 1.8 g/Mg lead for Pb; 0.1 g/Mg lead for Cd; 0.1 g/Mg lead for Hg; 0.1 g/Mg lead for As; 0.6 g/Mg lead for Zn; 2 g/Mg lead for PCB; and 4.5 µg I-TEQ/Mg lead for PCDD/F.

The CO₂ emissions from lead production are estimated using the following Tier 1 equation:

$$E_{CO_2} = DS \times EF_{DS} + ISF \times EF_{ISF} + S \times EF_S$$

where:

E_{CO_2} = CO₂ emissions from lead production, tonnes

DS = quantity of lead produced by Direct Smelting, tonnes

EF_{DS} = emission factor for Direct Smelting, tonne CO₂/tonne lead product

ISF = quantity of lead produced from the Imperial Smelting Furnace, tonnes

EF_{ISF} = emission factor for Imperial Smelting Furnace, tonne CO₂/tonne lead product

S = quantity of lead produced from secondary materials, tonnes

EF_S = emission factor for secondary materials, tonne CO₂/tonne lead product

The Tier 1 method requires only the amount of lead produced in the country and if available, the amount produced by furnace type. These data may be available from governmental agencies responsible for manufacturing statistics, business or industry trade associations, or individual lead companies.

The default emission factors for CO₂, as provided in the 2006 IPCC Guidelines for National Greenhouse Gas Inventories, are: 0.59 tonnes CO₂/tonne product from Imperial Smelt Furnace (ISF) production; 0.25 tonnes CO₂/tonne product from Direct Smelting (DS) production; 0.2 tonnes CO₂/tonne product from treatment of secondary raw materials; and 0.52 for a default emission factor assuming 80 percent ISF and 20 percent DS. When the only data available are national lead production statistics, it is good practice to use default emission factor of 0.52 tonne of CO₂/ tonne of lead.

4.3.3.4.4. Spatial allocation

Lead production plants should be considered as point sources if emissions can be calculated from available plant-specific data. Otherwise, national emissions should be disaggregated based on plant capacity, employment or population statistics to calculate non-point source emissions.

4.3.3.4.5. Summary of steps in the process

1. Identify activity data on lead production. When estimating CO₂ emissions, identify lead produced from Direct Smelting, Imperial Smelting Furnace, and secondary materials.
2. Calculate total emissions by combining activity data, emission factors (adjusted if necessary) and any other data required.
3. Spatially and temporally disaggregate as required.

4.3.3.4.6. Comments on reliability

The emission factor estimates are based on a large number of measurements made at a large number of facilities that represent a large part of the sector and have a typical error range of 20-60 percent.

The CO₂ Tier 1 method calculates emissions from general emission factors applied to a country's total lead production and is the least accurate. National production statistics should be available and likely have an uncertainty of ± 10 percent. This method is

appropriate only when lead production is not a key category. The uncertainty in the default CO₂ factor is high, up to +/- 50 percent, and varies depending on the mix of production methods and the percentage of secondary processing.

4.3.3.4.7. Sources of further information

Europe

- EEA (2016), EMEP/EEA Air Pollutant Emission Inventory Guidebook (European Environment Agency, Copenhagen, Denmark), 2016 Edition. <http://www.eea.europa.eu/publications/emep-eea-guidebook-2016>.

International

- IPCC (2006), 2006 Intergovernmental Panel on Climate Change Guidelines for National Greenhouse Gas Inventories Prepared by the National Greenhouse Gas Inventories Programme, Eggleston H.S., Buendia L., Miwa K., Ngara T. and Tanabe K. (eds). Published: IGES, Japan. <http://www.ipcc-nggip.iges.or.jp/public/2006gl/>.

US

- US EPA (1995-2018), Compilation of Air Pollutant Emission Factors, Volume I, Stationary Point and Area Sources, Chapter 12: Metallurgical Industry, Section 12.6, Primary Lead Smelting. AP-42 (United States Environmental Protection Agency, North Carolina, US), 5th Edition. <https://www3.epa.gov/ttn/chief/ap42/ch12/final/c12s06.pdf>.

4.3.3.5. Zinc production

4.3.3.5.1. Nature of the source and relevant pollutants

Zinc is produced from various primary and secondary raw materials. The primary processes use sulphidic and oxidic concentrates, while in secondary processes recycled oxidised and metallic products mostly from other metallurgical operations are employed. In practice, a clear distinction of primary and secondary zinc production is often difficult because many smelters use both primary and secondary raw materials.

The majority of the EU production facilities apply a hydrometallurgical production route, which is also called RLE (roast-leach-electro win). The activities relevant for primary zinc production are transport and storage of zinc ores; concentration of zinc ores; oxidation of zinc concentrates with air (roasting process); production of zinc by the electrochemical or the thermal process; and after-treatment of zinc. The most important pollutants emitted from these processes are sulphur dioxide, metals (particularly zinc) and dust.

Primary zinc is produced from ores which contain 85% zinc sulphide (by weight) and 8–10% iron sulphide, with the total zinc concentration about 50%. The ores also contain metal sulphides such as lead, cobalt, copper, silver, cadmium, and arsenic sulphide. A secondary zinc smelter is defined as any plant or factory in which zinc-bearing scrap or zinc-bearing materials, other than zinc-bearing concentrates (ores) derived from a mining operation, are processed.

Zinc recovery involves three general operations performed on scrap, namely pre-treatment, melting, and refining. Scrap metal is delivered to the secondary zinc processor as ingots, rejected castings, flashing and other mixed metal scrap containing zinc. Pure zinc scrap is

melted in kettle, crucible, reverberatory and electric induction furnaces. Refining processes remove further impurities from clean zinc alloy scrap and from zinc vaporised during the melt phase in retort furnaces. Final products from refining processes include zinc ingots, zinc dust, zinc oxide, and zinc alloys.

Very poor oxidic residues and oxidic dusts, e.g. from the steel industry, are treated in rotary furnaces (Waelz furnaces), producing metal oxides in a more concentrated form. These concentrated oxides (Waelz oxides) are processed together with oxidic ores in primary thermal zinc smelters, in particular Imperial smelting furnaces, which are in use for combined lead and zinc production. In this case, a clear discrimination between primary and secondary zinc production as well as between zinc and lead production is difficult. Metallic products prior to smelting are comminuted and sieved to separate metal grains from the oxides. Afterwards the metallic products are melted in melting furnaces, mainly of the induction type or muffle furnaces. Finally, the molten zinc is cast and in part refined to high purity zinc in distillation columns.

The main emissions to air from primary zinc production are SO₂, other sulphur compounds and acid mists; NO_x and other nitrogen compounds; metals and their compounds; dust; and VOCs and PCDD/F. Other pollutants are considered to be of negligible importance for the industry, partly because they are not present in the production process and partly because they are immediately neutralised (e.g. chlorine or HCl) or occur in very low concentrations (e.g. CO). Emissions are to a large extent bound to dust (except cadmium, arsenic and mercury, which can be present in the vapour phase to varying degrees). Dust carry-over from roasting or other pyrometallurgical processes are potential sources of direct and diffuse emissions of dust and metals. The melting, alloying, casting and zinc dust processes are potential emission sources of dust and metals. Emissions of particulate matter and metals (zinc and cadmium) also take place during the receipt and storage of the zinc ores.

Emissions of SO₂ mainly arise from the roasting, electrolysis and the sulphuric acid plant. More than 90% of the potential SO₂ emissions from zinc ores is released in roasters. Additional SO₂ is emitted from the sinter plant; the quantity depends on the sulphur content of the calcine feedstock. The roasting and smelting stages are potential sources of NO_x. The formation of PCDD/F in the combustion zone and in the cooling part of the off-gas treatment system (de novo synthesis) may be possible in some processes particularly if plastic components are included in the secondary materials that are fed into a process.

Among the various process steps in secondary zinc production the melting furnace operation represents the most important source of atmospheric emissions. In general, continuous and periodical emissions can be distinguished. Continuous emissions are connected with the process as such, whereas periodical emissions occur e.g. during charging, heating, skimming or cleaning operations. Continuous emissions from the melting furnace consist of combustion waste gases and gaseous effluents from the bath. Important periodical emissions often occur with charging and melting of the raw material. Emissions of organic compounds are mainly connected with charging operations. Furnace clearing, fluxing, ash drawing and also cleaning operations are of minor relevance. Tapping is carried out at low temperature and therefore no metal vapours are released. In zinc distillation a high quality input material is used and therefore, emissions of compounds containing carbon or chlorine are low. Emissions mainly consist of particles containing zinc and zinc oxide and combustion waste gases.

The primary zinc production pyrometallurgical process, involving the use of an Imperial Smelting Furnace which allows for the simultaneous treatment of lead and zinc concentrates, results in the simultaneous production of lead and zinc and the release of non-

energy CO₂ emissions. The sintering, smelting, and refining steps are identical to the steps used in the primary zinc production process, so certain smelting processes are considered emissive, while the sintering and refining steps are considered non emissive from the perspective of non-energy CO₂ emissions. When the concentration step involves the use of a carbon-containing reductant and high temperatures to volatilize or fume zinc from the source materials, the process could result in non-energy CO₂ emissions.

More information on the primary zinc production techniques including electrochemical zinc production process and the thermal smelting zinc production process as well as secondary zinc production techniques can be found in Chapter 2.C.6 of the 2016 EMEP/EEA Air Pollutant Emission Inventory Guidebook.

This section only covers process related zinc production emissions. The combustion related emissions are covered in the stationary combustion section.

4.3.3.5.2. Factors affecting releases

In primary zinc production, sulphur dioxide emissions from the roasting processes are often recovered at on-site sulphuric acid plants. No sulphur controls are used on the exhaust stream of sinter plants. Extensive desulphurisation before electrothermic retorting results in practically no SO₂ emissions from these devices. Dust control may be performed using bag filters, hot ESPs or wet scrubbers.

In secondary zinc production, most of the secondary zinc smelters are equipped with dust removing installations, such as baghouses. In general, emission control systems vary depending on the type of scrap being processed and the products being obtained. A distinction can be made between purely oxidised, mixed oxidised/metallic and purely metallic products. The control efficiency of dust removing installations is often very high, reaching 99.9 percent. Both primary gases and fugitive dust emissions are reduced in baghouses to concentrations below 10 mg/m³.

4.3.3.5.3. Description of release estimation techniques

The measurements of emissions of particulate matter from lead production above may use techniques which give filterable, condensable, or total PM and depends to a large extent on the measurement conditions.

For activities involving high temperature and semi-volatile emission components, the PM emission may be partitioned between a solid/aerosol phase and material which is gaseous at the sampling point but which can condense in the atmosphere. Dependent on the temperature of flue gases and in sampling equipment, the portion of filterable and condensable material will vary. Filterable PM measurement methods typically filter temperatures of 70-160°C and condensable fractions can be determined by recovering condensed material from chilled impinger systems downstream of a filter. A common approach for total PM includes dilution where sampled flue or exhaust gases are mixed with ambient air (either using a dilution tunnel or dilution sampling systems) which collect the filterable and condensable components on a filter at lower temperatures (but depending on the method this can be 15-52°C). The Tier 1 PM emission factors have been reviewed to identify if the data represent filterable, total (filterable and condensable) PM, or whether the basis of the emission factor cannot be determined. The PM emission factors represent primary emissions from the activities and not formation of secondary aerosol from chemical reaction in the atmosphere after release.

The SO_x, TSP, PM₁₀, PM_{2.5}, Pb, Cd, Hg, As, Zn, PCB, PCDD/F, and CO₂ (when the process type is unknown) emissions from zinc production are estimated using the following Tier 1 equation:

$$E_{\text{pollutant}} = AR_{\text{production}} \times EF_{\text{pollutant}}$$

where:

$E_{\text{pollutant}}$ = the emission of the specified pollutant

$AR_{\text{production}}$ = the activity rate for zinc production

$EF_{\text{pollutant}}$ = the emission factor for this pollutant

The emission equation assumes an average or typical technology and abatement implementation in the country and integrates all the different sub-processes. Activity data on the production of zinc is available from the United Nations statistical yearbooks or national statistics.

The PM emission factors represent filterable PM emissions only, excluding any condensable fraction. A conventional plant is assumed, using electrostatic precipitators (ESP), settlers and scrubbers for abatement and having moderate control of fugitive sources. The metal emission factors assume limited control. The emission factors, as provided in the 2016 EMEP/EEA Air Pollutant Emission Inventory Guidebook, are: 1350 g/Mg zinc for SO_x; 15 g/Mg zinc for TSP; 13 g/Mg zinc for PM₁₀; 12 g/Mg zinc for PM_{2.5}; 0.2 g/Mg zinc for Pb; 0.04 g/Mg zinc for Cd; 0.04 g/Mg zinc for Hg; 0.03 g/Mg zinc for As; 5 g/Mg zinc for Zn; 2 g/Mg zinc for PCB; and 5 µg I-TEQ/Mg lead for PCDD/F. The default emission factor for CO₂, as provided in the 2006 IPCC Guidelines for National Greenhouse Gas Inventories, are: 1.72 tonne of CO₂/tonne zinc for default zinc production without the known process type.

The CO₂ (when the process type is known) emissions from zinc production are estimated using the following Tier 1 equation:

$$E_{\text{CO}_2} = ET \cdot EF_{\text{ET}} + PM \cdot EF_{\text{PM}} + WK \cdot EF_{\text{WK}}$$

where:

E_{CO_2} = CO₂ emissions from zinc production, tonnes

ET= quantity of zinc produced by electro-thermic distillation, tonnes

EF_{ET} = emission factor for electro-thermic distillation, tonnes CO₂/tonne zinc produced

PM = quantity of zinc produced by pyrometallurgical process (Imperial Smelting Furnace Process), tonnes

EF_{PM} = emission factor for pyrometallurgical process, tonnes CO₂/tonne zinc produced

WK = quantity of zinc produced by Waelz Kiln process, tonnes

EF_{WK} = emission factor for Waelz Kiln process, tonnes CO₂/tonne zinc produced

The Tier 1 CO₂ method requires only the amount of zinc produced in the country, and if available, the process type. These data may be available from governmental agencies responsible for manufacturing statistics, business or industry trade associations, or individual zinc companies.

The default emission factors for CO₂, as provided in the 2006 IPCC Guidelines for National Greenhouse Gas Inventories, are: 3.66 tonnes of CO₂/tonne zinc for the Waelz Kiln process; 0.43 tonne of CO₂/tonne zinc for the Pyrometallurgical (Imperial Smelting Furnace) process; and unknown for the electro-thermic process as there are no data available to determine an emission factor.

4.3.3.5.4. Spatial allocation

Zinc production plants should be considered as point sources if emissions can be calculated from available plant-specific data. Otherwise, national emissions should be disaggregated based on plant capacity, employment or population statistics to calculate non-point source emissions.

4.3.3.5.5. Summary of steps in the process

1. Identify activity data on zinc production. When estimating CO₂ emissions, identify lead produced from electro-thermic distillation, pyrometallurgical (ISF) process, and the Waelz Kiln process.
2. Calculate total emissions by combining activity data, emission factors (adjusted if necessary) and any other data required.
3. Spatially and temporally disaggregate as required.

4.3.3.5.6. Comments on reliability

The emission factor estimates are based on a large number of measurements made at a large number of facilities that represent a large part of the sector and have a typical error range of 20-60 percent.

The Tier 1 CO₂ method is very simple and it may lead to errors due to its reliance on assumptions rather than actual data. The Tier 1 method calculates emissions from general emission factors applied to a country's total zinc production and is the least rigorous method. This method should only be used when zinc production is not a key category. The default CO₂ emission factors used in Tier 1 may have an uncertainty of ± 50 percent, while the process specific CO₂ emission factors may have an uncertainty of ± 20 percent. National production statistics should be available and likely have an uncertainty of ± 10 percent.

4.3.3.5.7. Sources of further information

Europe

- EEA (2016), EMEP/EEA Air Pollutant Emission Inventory Guidebook (European Environment Agency, Copenhagen, Denmark), 2016 Edition. <http://www.eea.europa.eu/publications/emep-eea-guidebook-2016>.

International

- IPCC (2006), 2006 Intergovernmental Panel on Climate Change Guidelines for National Greenhouse Gas Inventories Prepared by the National Greenhouse Gas Inventories Programme, Eggleston H.S., Buendia L., Miwa K., Ngara T. and Tanabe K. (eds). Published: IGES, Japan. <http://www.ipcc-nggip.iges.or.jp/public/2006gl/>.

US

- US EPA (1995-2018), Compilation of Air Pollutant Emission Factors, Volume I, Stationary Point and Area Sources, Chapter 12: Metallurgical Industry, Section 12.7, Zinc Smelting. AP-42 (United States Environmental Protection Agency, North Carolina, US), 5th Edition. <https://www3.epa.gov/ttn/chief/ap42/ch12/final/c12s07.pdf>.

4.3.3.6. Copper production

4.3.3.6.1. Nature of the source and relevant pollutants

Production of copper includes the production of primary and secondary copper. There is an overall trend in copper production towards integrated/multi metallic smelters, where primary smelters are using increasingly secondary material feeds and secondary smelters are using also sulphur containing feeds.

Generally speaking, there are three steps in the pyrometallurgical primary copper production process: roasting of ores to remove sulphur; smelting of roaster product to remove a part of the gangue for production of the copper matte; and converting the copper matte to blister copper. In the traditional pyrometallurgical copper smelting process, the blister copper is fire refined in an anode furnace, cast into 'anodes' and sent to an electrolytic refinery for further impurity elimination. In the smelting process, calcines are melted with siliceous flux in a flash smelting furnace to produce copper matte, a molten mixture of cuprous sulphide, ferrous sulphide, and some trace elements.

In the converting process during primary copper production, two techniques can be distinguished: batch converting blowing an air/oxygen mixture through the matte recovered from the smelting operation; and continuous converting, of which three types exist. The Mitsubishi and Noranda converters receive molten feed for conversion, while in the Kennecott/Outokumpu process the matte from the smelting furnace is first granulated in water, crushed and dried.

Atmospheric emissions of sulphur dioxide and metals on fine particles occur during all the primary copper production processes. Various trace elements from impurities are present in the copper ores, which are emitted during the production process. The process is a major source of atmospheric arsenic and copper (50 percent of the global emissions of these elements), indium (almost 90 percent), antimony, cadmium and selenium (approximately 30 percent), and nickel and tin (approximately 10 percent).

In secondary copper smelting, pyrometallurgical processes are used to rework scrap and other secondary materials. As with primary copper production, final refining, where practised, is electrolytic. A secondary copper smelter is defined as any plant or factory in which copper-bearing scrap or copper-bearing materials, other than copper-bearing concentrates (ores) derived from a mining operation, is processed by metallurgical or chemical process into refined copper and copper powder (a premium product). The recycling of copper is the most comprehensive among the non-ferrous metals. Depending on their chemical composition, the raw materials of a secondary copper smelter are processed in different types of furnaces.

Pollutants released during copper production are particulate matter, SO_x, NO_x, volatile organic compounds (non-methane VOC and CH₄), CO, CO₂, N₂O, trace elements, and selected persistent organic pollutants (POPs). The POPs are mostly dioxins and furans, which are emitted from shaft furnaces, converters, and flame furnaces.

Copper smelters are a source SO_x . Emissions are generated from the roasters, smelting furnaces and converters. Fugitive emissions are generated during material handling operations. Remaining smelter operations use material containing very little sulphur, resulting in insignificant SO_2 emissions. This section only covers process related copper production emissions. The combustion related emissions are covered in the stationary combustion section.

More information on the primary and secondary copper production techniques can be found in Chapter 2.C.7 of the 2016 EMEP/EEA Air Pollutant Emission Inventory Guidebook.

4.3.3.6.2. Factors affecting releases

Emission controls on primary copper smelters are employed for controlling sulphur dioxide and particulate matter emissions resulting from roasters, smelting furnaces, and converters. Control of sulphur dioxide emissions is achieved by absorption to sulphuric acid in the sulphuric acid plants, which are commonly a part of copper smelting plants. Electrostatic precipitators (ESPs) are the common particulate matter control devices employed at copper smelting facilities.

Controls in secondary copper production should include effective emission collecting arrangements such as hooding, enclosure and boosted suction systems for both primary exhaust gases and fugitive emissions. Reducing dust and metal emissions can be done using a bag filter and/or a scrubber in combination with an ESP. The use of an afterburner, quench, injection of lime and/or active coal before the bag filter may further reduce emission levels, including emissions of dioxin and other organic compounds.

4.3.3.6.3. Description of release estimation techniques

The measurements of emissions of particulate matter from lead production above may use techniques which give filterable, condensable, or total PM and depends to a large extent on the measurement conditions.

For activities involving high temperature and semi-volatile emission components, the PM emission may be partitioned between a solid/aerosol phase and material which is gaseous at the sampling point but which can condense in the atmosphere. Dependent on the temperature of flue gases and in sampling equipment, the portion of filterable and condensable material will vary. Filterable PM measurement methods typically filter temperatures of 70-160°C and condensable fractions can be determined by recovering condensed material from chilled impinger systems downstream of a filter. A common approach for total PM includes dilution where sampled flue or exhaust gases are mixed with ambient air (either using a dilution tunnel or dilution sampling systems) which collect the filterable and condensable components on a filter at lower temperatures (but depending on the method this can be 15-52°C). The Tier 1 PM emission factors have been reviewed to identify if the data represent filterable, total (filterable and condensable) PM, or whether the basis of the emission factor cannot be determined. The PM emission factors represent primary emissions from the activities and not formation of secondary aerosol from chemical reaction in the atmosphere after release.

The TSP, PM_{10} , $PM_{2.5}$, BC^2 , SO_x , Pb, Cd, Hg, As, Cr, Cu, Ni, PCB, and PCDD/F emissions from copper production are estimated using the following Tier 1 equation:

$$E_{\text{pollutant}} = AR_{\text{production}} \times EF_{\text{pollutant}}$$

where:

$E_{\text{pollutant}}$ = the emission of the specified pollutant

$AR_{\text{production}}$ = the activity rate for copper production

$EF_{\text{pollutant}}$ = the emission factor for this pollutant

The emission equation assumes an average or typical technology and abatement implementation in the country and integrates all different sub-processes in the production of copper, from the treatment of the ore concentrate until after the fire refining, producing anode copper. Activity data on the production of copper is available from the United Nations statistical yearbooks or national statistics.

The emission factors, as provided in the 2016 EMEP/EEA Air Pollutant Emission Inventory Guidebook, are: 320 g/Mg copper for TSP; 250 g/Mg copper for PM₁₀; 190 g/Mg copper for PM_{2.5}; 0.1 % of PM_{2.5} for BC²; 3000 g/Mg copper for SO_x; 19 g/Mg copper for Pb; 11 g/Mg copper for Cd; 0.023 g/Mg copper for Hg; 4 g/Mg copper for As; 16 g/Mg copper for Cr; 32 g/Mg copper for Cu; 14 g/Mg copper for Ni; 0.9 g/Mg copper for PCBs; and 5 µg I-TEQ/Mg copper for PCDD/F.

4.3.3.6.4. Spatial allocation

Copper production plants should be considered as point sources if emissions can be calculated from available plant-specific data. Otherwise, national emissions should be disaggregated based on plant capacity, employment or population statistics to calculate non-point source emissions.

4.3.3.6.5. Summary of steps in the process

1. Identify activity data on copper production.
2. Calculate total emissions by combining activity data, emission factors (adjusted if necessary) and any other data required.
3. Spatially and temporally disaggregate as required.

4.3.3.6.6. Comments on reliability

There are no specific emission factor or activity data uncertainties associated with other metal production.

4.3.3.6.7. Sources of further information

Europe

- EEA (2016), EMEP/EEA Air Pollutant Emission Inventory Guidebook (European Environment Agency, Copenhagen, Denmark), 2016 Edition. <http://www.eea.europa.eu/publications/emep-eea-guidebook-2016>.

US

- US EPA (1995-2018), Compilation of Air Pollutant Emission Factors, Volume I, Stationary Point and Area Sources, Chapter 12: Metallurgical Industry, Section 12.3, Primary Copper Smelting. AP-42 (United States Environmental Protection Agency, North Carolina, US), 5th Edition. <https://www3.epa.gov/ttn/chief/ap42/ch12/final/c12s03.pdf>.

4.3.3.7. Nickel production

4.3.3.7.1. Nature of the source and relevant pollutants

Nickel is produced from oxidic (laterite and saprolite) or sulphidic ore with about 40 percent coming from oxide deposits and about 60 percent coming from sulphide deposits. There are several variations in the processes used to produce nickel from these ores and these variations are dependent on the grade of the concentrate and also on the other metals that are present in the material.

The production of nickel includes primary production, which sulphidic or oxide ore, and secondary production, which uses scrap as an input. In many cases scrap containing nickel is used to produce stainless steel at ferrous industry plants instead of pure nickel production. The energy consumed for the production of matte from sulphidic ores is reported to be in the range of 25– 65 GJ per tonne of nickel for ores containing 4–15 percent nickel. The energy consumed in the various refining stages is reported to be 17–20 GJ per tonne of nickel.

The potential emissions of concern to air from nickel production are: SO_x and other acid gases; NO_x and other nitrogen compounds; metals and their compounds including As; dust; chlorine; VOCs and odours; and CO and carbonyls (alarm levels set at 80 parts per billion). The major sources of sulphur dioxide emissions are diffuse emissions from the roaster or smelter. Uncaptured emissions from the ladle transfer and blowing stages of the converter and direct emissions from the sulphuric acid plant are also significant. Dust carry-over from the roasting, smelting, and converting processes is a potential source of direct and diffuse emissions of dust and metals.

Emissions from nickel production, as discussed here, only consider process related emissions of SO_x, TSP, and nickel. Emitted sulphur oxides are to a large extent from the ore and therefore are included in the estimation of emissions from the production of nickel. Emissions of nitrogen oxides and carbon monoxide are assumed to be mainly due to combustion activities. Therefore, these emissions are included in the stationary combustion emissions estimation. Fugitive emissions can also occur but are only important if ventilation gases are not collected and treated. Fugitive emissions are not included in the estimation of emissions from nickel production.

4.3.3.7.2. Factors affecting releases

Good extraction and sealing of the furnaces prevents diffuse emissions and the collected gases are passed to a gas-cleaning plant and then to the sulphuric acid plant. In some processes, the gases are collected and treated in scrubbers and fabric filters or in the gas-cleaning processes of a sulphuric acid plant. Dust is removed and returned to the leaching process. Fabric filters and scrubbers are used to remove dust and large particles.

4.3.3.7.3. Description of release estimation techniques

The measurements of emissions of particulate matter from nickel production above may use techniques which give filterable, condensable, or total PM and depends to a large extent on the measurement conditions. Note that PM emission factors represent primary emissions from the activities and not formation of secondary aerosol from chemical reaction in the atmosphere after release.

For activities involving high temperature and semi-volatile emission components, the PM emission may be partitioned between a solid/aerosol phase and material which is gaseous

at the sampling point but which can condense in the atmosphere. Dependent on the temperature of flue gases and in sampling equipment, the portion of filterable and condensable material will vary. Filterable PM measurement methods typically filter temperatures of 70-160°C and condensable fractions can be determined by recovering condensed material from chilled impinger systems downstream of a filter. A common approach for total PM includes dilution where sampled flue or exhaust gases are mixed with ambient air (either using a dilution tunnel or dilution sampling systems) which collect the filterable and condensable components on a filter at lower temperatures (but depending on the method this can be 15-52°C). The Tier 1 PM emission factors have been reviewed to identify if the data represent filterable, total (filterable and condensable) PM, or whether the basis of the emission factor cannot be determined.

The SO_x, TSP, and nickel emissions from nickel production are estimated using the following Tier 1 equation:

$$E_{\text{pollutant}} = AR_{\text{production}} \times EF_{\text{pollutant}}$$

where:

$E_{\text{pollutant}}$ = the emission of the specified pollutant

$AR_{\text{production}}$ = the activity rate for nickel production

$EF_{\text{pollutant}}$ = the emission factor for this pollutant

Activity data on the production of nickel is available from the United Nations statistical yearbooks or national statistics.

The emission factors assume an average or typical technology and abatement implementation in the country and integrate all sub-processes. The PM factors represent filterable PM emissions only, excluding any condensable fraction. The emission factors, as provided in the 2016 EMEP/EEA Air Pollutant Emission Inventory Guidebook, are: 18 kg/Mg nickel produced for SO_x; 0.3 kg/Mg nickel produced for TSP, and 0.025 kg/Mg nickel produced for nickel.

4.3.3.7.4. Spatial allocation

Nickel production plants should be considered as point sources if emissions can be calculated from available plant-specific data. Otherwise, national emissions should be disaggregated based on plant capacity, employment or population statistics to calculate non-point source emissions.

4.3.3.7.5. Summary of steps in the process

1. Identify activity data on nickel production.
2. Calculate total emissions by combining activity data, emission factors (adjusted if necessary) and any other data required.
3. Spatially and temporally disaggregate as required.

4.3.3.7.6. Comments on reliability

There are no specific emission factor or activity data uncertainties associated with nickel production.

4.3.3.7.7. Sources of further information

Europe

- EEA (2016), EMEP/EEA Air Pollutant Emission Inventory Guidebook (European Environment Agency, Copenhagen, Denmark), 2016 Edition. <http://www.eea.europa.eu/publications/emep-eea-guidebook-2016>.

4.3.3.8. *Other metal production*

4.3.3.8.1. Nature of the source and relevant pollutants

Other metal production addresses the production of all metals that are not covered in the specific metal production sections.

Emissions from other metal production are generally not considered significant, since they contribute less than 1 percent to the national emissions of any pollutant. The main process related emissions are from SO_x, dust, and metals. Significant process emissions of NO_x may also occur as a result of acid digestion using nitric acid. NO_x emissions in precious metal manufacturing may range from 7 to more than 150 kt/t of metal produced. Combustion related emissions are not included in this section, but are in the stationary combustion section.

4.3.3.8.2. Factors affecting releases

Common emission control techniques are ESPs, baghouse filters, sulphuric acid plants and wet scrubbing. To limit diffuse emissions, proper sealing or hooding of processes may be applied.

4.3.3.8.3. Description of release estimation techniques

The measurements of emissions of particulate matter from nickel production above may use techniques which give filterable, condensable, or total PM and depends to a large extent on the measurement conditions. Note that PM emission factors represent primary emissions from the activities and not formation of secondary aerosol from chemical reaction in the atmosphere after release.

For activities involving high temperature and semi-volatile emission components, the PM emission may be partitioned between a solid/aerosol phase and material which is gaseous at the sampling point but which can condense in the atmosphere. Dependent on the temperature of flue gases and in sampling equipment, the portion of filterable and condensable material will vary. Filterable PM measurement methods typically filter temperatures of 70-160°C and condensable fractions can be determined by recovering condensed material from chilled impinger systems downstream of a filter. A common approach for total PM includes dilution where sampled flue or exhaust gases are mixed with ambient air (either using a dilution tunnel or dilution sampling systems) which collect the filterable and condensable components on a filter at lower temperatures (but depending on the method this can be 15-52°C). The review identifies if the data represent filterable, total (filterable and condensable) PM, or whether the basis of the emission factor cannot be determined.

The TSP and SO_x emissions from other metal production are estimated using the following Tier 1 equation:

$$E_{\text{pollutant}} = AR_{\text{production}} \times EF_{\text{pollutant}}$$

where:

$E_{\text{pollutant}}$ = the emission of the specified pollutant

$AR_{\text{production}}$ = the activity rate for other metal production

$EF_{\text{pollutant}}$ = the emission factor for this pollutant

Activity data on the production of nickel is available from the United Nations statistical yearbooks or national statistics.

The emission factors assume an average or typical technology and abatement implementation in the country and integrate all sub-processes. The PM factors represent filterable PM emissions only, excluding any condensable fraction. The emission factors, as provided in the 2016 EMEP/EEA Air Pollutant Emission Inventory Guidebook, are: 16 kg/Mg metal produced for TSP and 26 kg/Mg metal produced for SO_x.

4.3.3.8.4. Spatial allocation

Other metal production plants should be considered as point sources if emissions can be calculated from available plant-specific data. Otherwise, national emissions should be disaggregated based on plant capacity, employment or population statistics to calculate non-point source emissions.

4.3.3.8.5. Summary of steps in the process

1. Identify activity data for the metal production.
2. Calculate total emissions by combining activity data, emission factors (adjusted if necessary) and any other data required.
3. Spatially and temporally disaggregate as required.

4.3.3.8.6. Comments on reliability

There are no specific emission factor or activity data uncertainties associated with other metal production.

4.3.3.8.7. Sources of further information

Europe

- EEA (2016), EMEP/EEA Air Pollutant Emission Inventory Guidebook (European Environment Agency, Copenhagen, Denmark), 2016 Edition. <http://www.eea.europa.eu/publications/emep-eea-guidebook-2016>.

US

- US EPA (1995-2018), Compilation of Air Pollutant Emission Factors, Volume I, Stationary Point and Area Sources, Chapter 12: Metallurgical Industry, AP-42 (United States Environmental Protection Agency, North Carolina, US), 5th Edition. <https://www3.epa.gov/ttn/chief/ap42/ch12/index.html>.

4.3.3.9. Storage, handling, and transport of metal products

4.3.3.9.1. Nature of the source and relevant pollutants

Emissions from storage, handling, and transport of metal products can occur before, during, and after the activities described in the metal industry. For more information about the storage, handling, and transport of metal products for a specific production process, consult that section as the storage, handling, and transport of metal products emissions are included in the Tier 1 methodology for each section.

4.3.3.9.2. Factors affecting releases

For more information about the storage, handling, and transport of metal products for a specific production process, consult that section as the storage, handling, and transport of metal products emissions are included in the Tier 1 methodology for each section.

4.3.3.9.3. Description of release estimation techniques

The 2016 EMEP/EEA Air Pollutant Emission Inventory Guidebook provides emission factors for storage, handling, and transport but these emission factors are considered to be Tier 2 emission factors. In the default Tier 1 approach, it is assumed that emissions from storage, handling, and transport of metal products are included in the Tier 1 from the relevant section in the metal industry. For example, emissions from storage, handling, and transport of steel during the iron and steel production process are covered by the Tier 1 emission factors for iron and steel production. If in the relevant process chapters (such as Iron and Steel Production and Ferroalloys Production) a Tier 1 methodology is applied, the storage, handling, and transport is already included in the applied emission factors. In this case, an ‘included elsewhere’ (IE) notation key should be used for reporting under this category to avoid double counting. Where higher tiers are used in the relevant process chapters, a separate estimate for the handling, and storage should be made using the methods described below. As the document only discusses Tier 1 methodologies, consult the EEA guidebook for more information.

4.3.3.9.4. Spatial allocation

For more information about the storage, handling, and transport of metal products for a specific production process, consult that section as the storage, handling, and transport of metal products emissions are included in the Tier 1 methodology for each section.

4.3.3.9.5. Summary of steps in the process

For more information about the storage, handling, and transport of metal products for a specific production process, consult that section as the storage, handling, and transport of metal products emissions are included in the Tier 1 methodology for each section.

4.3.3.9.6. Comments on reliability

For more information about the storage, handling, and transport of metal products for a specific production process, consult that section as the storage, handling, and transport of metal products emissions are included in the Tier 1 methodology for each section.

4.3.3.9.7. Sources of further information

Europe

- EEA (2016), EMEP/EEA Air Pollutant Emission Inventory Guidebook (European Environment Agency, Copenhagen, Denmark), 2016 Edition. <http://www.eea.europa.eu/publications/emep-eea-guidebook-2016>.

US

- US EPA (1995-2018), Compilation of Air Pollutant Emission Factors, Volume I, Stationary Point and Area Sources, Chapter 13: Miscellaneous Sources, Section 13.2.4, Aggregate handling and Storage Piles. AP-42 (United States Environmental Protection Agency, North Carolina, US), 5th Edition. <https://www3.epa.gov/ttn/chief/ap42/ch13/final/c13s0204.pdf>.

4.4. Summary of Techniques for Product Use

4.4.1. Solvent-containing products

Three categories are considered here: industrial solvents, architectural surface coatings and domestic/commercial solvents. Other categories commonly included in inventories are: dry cleaning, printing and graphic arts, industrial surface coatings, motor vehicle refinishing and cutback bitumen. Methodologies are very similar across this group of sources.

4.4.1.1. Industrial solvent-containing products

4.4.1.1.1. Nature of the source and relevant pollutants

Solvents are used extensively by industry for solvent degreasing and surface cleaning (*i.e.* essentially to remove unwanted materials from hard surfaces). This is often done to prepare surfaces for painting, electroplating, galvanising, tin plating or varnishing. This category excludes other solvents used for architectural surface coatings (see Section 4.4.2), motor vehicle refinishing and printing and graphic arts, which are normally estimated separately.

The solvents used by industry may contain one or more of a range of VOCs, such as trichloroethylene, tetrachloroethylene, carbon tetrachloride, chloroform and methyl ethyl ketone. The types of solvents used vary from country to country. In Australia, for example, industrial solvents are predominantly trichloroethylene; this simplifies the inventory process.

Industrial cleaning activities can be categorised as follows:

1. Batch cold cleaning machines. These use liquid solvents at room temperature and are generally represented by a large number of small sources.
2. Batch vapour-cleaning machines. These use solvent vapours from halogenated compounds.
3. In-line cleaning machines. These are larger machines with automated continuous loading and emissions are generally included with point source estimates. Solvents may be used in vapour or liquid modes.
4. Clean-up solvent use. This is often done by wiping.

4.4.1.1.2. Factors affecting releases

Many control processes can reduce emissions from solvents. These may include the use of covers, measures to prevent emissions during malfunctions, distillation of vapours, low pressure spraying, and product reformulation to reduce volatility.

4.4.1.1.3. Description of release estimation techniques

Emissions from industrial solvents are normally estimated as an area source with adjustment made for contributions reported by point sources. Emissions estimation is based on a mass balance approach, assuming that all VOCs in the solvents used across the airshed evaporate to the atmosphere. The following general approaches may be used to collecting activity data:

1. Conduct detailed surveys of solvent users. This requires identifying facilities to be surveyed which adequately represent the total industrial sector and gathering data on the types and amounts of solvent used for the different cleaning activities, level of emissions control applied and any recycling or disposal of solvents off-site. This method is the most accurate but also the most resource intensive. Refer to the EIIP report (Section 3.1.2) for guidance on surveys of users and suppliers.
2. Obtain sales data from suppliers. This may be sufficiently accurate if all substances used can be easily identified and sales data are readily obtained from suppliers (*e.g.* as is the case in Australia). Control technologies will not normally be accounted for (unless they are subject to regulation or other information is available) and it may be necessary to scale down sales data from a larger area using employment or population data. It is also necessary to adjust emissions downward to allow for the point source component.
3. Use published emission factors (in per capita, per employee, or per equipment unit in use terms). This is the least accurate of the three methods. See EIIP on Solvent Cleaning (Table 6.5-2) for per capita and per employee emission factors and AP-42 on solvent degreasing (Table 4.6-2) for per unit emission factors (kg/yr/unit). The latter factors are reproduced in the EMEP/EEA Guidebook (Section 2.D.3.e).

If the HAPs contained in any of the solvents are included separately in the inventory, data on the composition of these solvents should also be obtained from suppliers.

4.4.1.1.4. Spatial allocation

Emissions could be spatially allocated according to industrial zones or according to industry employment data. A less accurate approach would be to use population density.

4.4.1.1.5. Summary of steps in the process

1. Review the types of solvents used by industry in the region, identify distributors and the availability of sales data.
2. Review the likely significance of the source and determine whether a detailed survey approach is necessary or whether a top-down approach (using sales data obtained from distributors) or default emission factors would be sufficient.
3. Collect activity data (either by survey or from distributors) or emission factors.
4. Estimate emissions and adjust by subtracting any point source contributions.

5. Spatially and temporally disaggregate as required.

4.4.1.1.6. Comments on reliability

The nature of the activity data will influence the resulting accuracy of emissions estimates. Using a top-down approach (assuming all solvents are used for cleaning and degreasing) may overestimate or double-count emissions with other source categories, as solvents may be used for other purposes. If no allowance is made for solvents that may be recycled, reclaimed or disposed of off-site, emissions may also be overestimated. If activity data are scaled down from a larger region, the extent to which the study region is representative of the larger region, (in terms of industrial activity), will also be important.

Using default emission factors from other countries may be quite inaccurate.

4.4.1.1.7. Sources of further information

Australia

- Environment Australia (1999), Emissions Estimation Technique Manual for Aggregated Emissions from Use of Industrial Solvents (Sub-threshold) (Environment Australia, Canberra, Australia). <http://www.npi.gov.au/system/files/resources/32c5dd6e-bc9f-c4a4-757f-7231d4cbd838/files/subsolventrev2.pdf>.

Europe

- EEA (2016), EMEP/EEA Air Pollutant Emission Inventory Guidebook (European Environment Agency, Copenhagen, Denmark), 2016 Edition. <http://www.eea.europa.eu/publications/emep-eea-guidebook-2016>.

US

- US EPA (1995-2018), Compilation of Air Pollutant Emission Factors, Volume I, Stationary Point and Area Sources, Chapter 4: Evaporative Loss Sources, AP-42 (United States Environmental Protection Agency, North Carolina, US), 5th Edition. <https://www3.epa.gov/ttn/chief/ap42/ch04/index.html>
- US EPA (1997), *Solvent Cleaning*, Chapter 6 from Volume III of EIIP Document Series, prepared by Eastern Research Group, US (United States Environmental Protection Agency, North Carolina, US). <https://www.epa.gov/sites/production/files/2015-08/documents/iii06fin.pdf>.

4.4.1.2. Architectural and surface coatings

4.4.1.2.1. Nature of the source and relevant pollutants

Architectural coatings involve the application of a thin layer of coating (paints, primers, varnish or lacquer) to buildings, furniture *etc.*, as well as the use of solvents as thinners and for clean-up. Architectural coatings are used for domestic, commercial, government and industrial structures. The VOCs used as solvents in the coatings are emitted during application and as the coating dries. VOCs may include specific HAPs of interest for a particular inventory, such as benzene and toluene.

Surface coatings include other categories not discussed here, such as those used for industrial purposes, traffic markings, graphic arts and automobile refinishing.

4.4.1.2.2. Factors affecting releases

The amount of coating used and its VOC content determine the emissions from architectural coatings. The relative weight fractions of any HAPs will determine their emissions. The amount of paint actually used can be reduced by increasing the solids content, decreasing the thickness of the coat, and increasing transfer efficiency (*i.e.* reducing wastage). Adding thinners to paints increases the solvent content and hence increases emissions.

Architectural coatings are normally known as solvent-based or water-based. Solvent-based coatings contain between 30 % and 70% VOCs by weight and water-based contain about 6%. Powder paints contain no solvents. Regulations exist in some countries or states limiting the VOC content of coatings.

4.4.1.2.3. Description of release estimation techniques

Estimating emissions from architectural surface coatings requires data on the total volume of the various products used and their VOC content and composition (*i.e.* speciation profiles). Architectural coatings and thinners can only be treated as an area source.

The three main approaches to gathering activity and product data are as follows:

1. The survey approach involves contacting paint distributors and/or manufacturers and seeking data on product types, content, and amounts distributed within the study region. This approach may also involve determining the amounts recycled or sent to landfill by surveying recycling facilities. (Refer to the EIIP report on architectural surface coatings). Emissions for each class of product identified would be estimated separately and then summed, and VOC content and composition data would determine the relevant emission factors. This approach is the most detailed and resource intensive.
2. The top-down approach involves scaling down national or state consumption data, usually according to population. This requires consumption data for the particular state or country, population data, as well as VOC content and composition data. Note that VOC content should automatically reflect any controls in place. Consumption data needs to be split into water and solvent-based paints with separate emission factors applied according to the average VOC content for each. Depending on the level of disaggregation of the consumption data, emissions could be estimated for various subgroups based on the VOC content for each, and then the emissions could be summed. The EIIP report provides default emission factors for the VOC content of solvent and water based paints (lb/gal) plus speciation profiles from CARB. The EMEP/EEA Guidebook also provides emission factors for the VOC content (g/kg) and a speciation profile from the UK.
3. A simple, but potentially inaccurate, method involves the use of default per capita emission factors, such as those provided in AP-42.

4.4.1.2.4. Spatial allocation

The most accurate approach possible would be to spatially allocate emissions according to a measure of building coverage. The most common approach is to use population distribution to disaggregate emissions spatially.

4.4.1.2.5. Summary of steps in the process

1. Review the nature and sources of activity data.
2. Decide on the most appropriate methodology, depending on the quality of available data, nature of the inventory and resources available.
3. Carry out a survey or gather consumption and other required data, or select default emission factors to be used.
4. Estimate emissions for all classes of coatings separately (unless default factors are used) and sum these to obtain total emissions.
5. Spatially and temporally disaggregate as required.

4.4.1.2.6. Comments on reliability

It is important to have reliable activity data that accurately reflect the different types of coatings and thinners used and their VOC content. The increasing use of water-based paints in many countries has a significant impact on emissions. Using default values (*e.g.* from another country) for VOC content and speciation profiles may be quite inaccurate, unless the coatings used are known to be very similar.

Scaling down national or state data may reduce accuracy if the study area has different characteristics that could influence the use of surface coatings (*e.g.* types of buildings, climate, proximity to the sea).

Using default per capita emission factors may be quite inaccurate.

4.4.1.2.7. Sources of further information

Australia

- Environment Australia (2003), Emissions Estimation Technique Manual for Aggregated Emissions from Architectural Surface Coatings (Environment Australia, Canberra, Australia). <http://www.npi.gov.au/system/files/resources/253a136a-c9cd-4c54-d9c4-f3e3fe70a42b/files/archcoat.pdf>.

Europe

- EEA (2016), EMEP/EEA Air Pollutant Emission Inventory Guidebook (European Environment Agency, Copenhagen, Denmark), 2016 Edition. <http://www.eea.europa.eu/publications/emep-eea-guidebook-2016>.

US

- US EPA (1995-2018), *Compilation of Air Pollutant Emission Factors, Volume I, Stationary Point and Area Sources, Chapter 4: Evaporation Loss Sources, Section 4.2.1, Nonindustrial Surface Coating. AP-42* (United States Environmental Protection Agency, North Carolina, US), 5th Edition. https://www3.epa.gov/ttn/chief/ap42/ch04/final/c4s02_1.pdf
- US EPA (1995), *Architectural Surface Coating*, Chapter 3 from Volume III of EIIP Document Series, prepared by Radian Corporation, US (United States Environmental Protection Agency, North Carolina, US). <https://www.epa.gov/sites/production/files/2015-08/documents/archsfc.pdf>.

4.4.1.3. Domestic and commercial solvent-containing products

4.4.1.3.1. Nature of the source and relevant pollutants

The VOCs released from consumer and commercial products result from the evaporation of solvents when these products are used. An extensive range of products is solvent-based and can be considered in the following categories:

- personal care products;
- household cleaning products;
- motor vehicle after-market products;
- adhesives and sealants;
- pesticides and herbicides;
- coatings and related products; and
- miscellaneous products.

VOCs are primarily released by immediate evaporation (aerosol spray), evaporation after application (product drying) and direct release in the gaseous phase. Specific organic HAPs may also be of interest for a particular inventory.

Releases from architectural surface coatings are covered in the previous section of this document (as the estimation of releases for coating are normally based on specific activity data). Releases associated with motor vehicle refinishing and broad-acre agricultural use of pesticides and herbicides are also not included here.

4.4.1.3.2. Factors affecting releases

Emissions from a particular product will depend on the amount and composition of the VOCs contained in the product, any controls on product formulation and the way in which the product is used.

4.4.1.3.3. Description of release estimation techniques

The normal method for estimating emissions from this source involves the use of per capita emission factors for the various sub-categories. Those derived in the US, which are based on extensive surveys of product manufacturers and industry associations, are widely used. Table 5.4-2 in the EIIP report on consumer and commercial solvent use contains per capita emissions factors for total VOCs as well as a range of HAPs (expressed in pounds per person per year). Note that these emission factors include only reactive VOCs – total VOCs are obtained by multiplying reactive VOCs by a factor of 1.45. Refer to the Australian NPI manual for US emission factors adjusted to include all VOCs and converted to kilogrammes per person per year. These emission factors are simply combined with population data to give total emissions. If any specific controls on product content are in place, then the emission factors can be adjusted accordingly.

The EMEP/EEA Guidebook provides alternative per capita emission factors for domestic solvents derived in the UK. These cover cosmetics and toiletries, household products, construction/DIY and car care products.

An alternative method would involve conducting a survey of distributors and/or retailers on types and quantities of products sold within the region. Information on VOC content

would also be needed from manufacturers and/or distributors. In some countries (*e.g.* the Netherlands), these types of statistics are collected and provided to government, allowing more accurate estimation of emissions. In most countries, however, the amount of effort required to compile the necessary data would make this approach impractical due to resource needs.

4.4.1.3.4. Spatial allocation

Emissions from domestic and commercial solvents would normally be spatially distributed according to population density.

4.4.1.3.5. Summary of steps in the process

1. Obtain population data (or carry out detailed surveys to produce specific emission factors if desired).
2. Identify relevant emission factors, taking care not to duplicate other sections of the inventory (*e.g.* surface coatings) and adjust for any regulations if necessary.
3. Multiply per capita emission factors for VOCs and other HAPs by population.
4. Spatially and temporally disaggregate emissions as required.

4.4.1.3.6. Comments on reliability

Reliability will depend on the emission factors used and on how much the range, availability and consumption of products reflects those of the US or UK. Emission factors for HAPs would be less reliable in another country, as the speciation profile of products may vary significantly according to product formulation. Product use may of course vary spatially within a study region, but may also differ from a national average.

4.4.1.3.7. Sources of further information

Australia

- Environment Australia (1999), Emissions Estimation Technique Manual for Aggregated Emissions from Domestic/Commercial Solvent and Aerosol Use (Environment Australia, Canberra, Australia). <http://www.npi.gov.au/system/files/resources/50d07831-eda6-e564-91d5-bfde6a529fa0/files/domcomsolventsrev.pdf>.

Europe

- EEA (2016), EMEP/EEA Air Pollutant Emission Inventory Guidebook (European Environment Agency, Copenhagen, Denmark), 2016 Edition. <http://www.eea.europa.eu/publications/emep-eea-guidebook-2016>.

US

- US EPA (1995-2018), Compilation of Air Pollutant Emission Factors, Volume I, Stationary Point and Area Sources, Chapter 4: Evaporative Loss Sources, Section 4.10, Commercial/Consumer Solvent Use. AP-42 (United States Environmental Protection Agency, North Carolina, US), 5th edition. <https://www3.epa.gov/ttn/chief/ap42/ch04/final/c4s10.pdf>
- US EPA (1996), *Consumer and Commercial Solvent Use*, Chapter 5 from Volume III of EIIP Document Series, prepared by Eastern Research Group, US (United

States Environmental Protection Agency, North Carolina, US).
<https://www.epa.gov/sites/production/files/2015-08/documents/iii05.pdf>.

4.4.2. Other products

4.4.2.1. Releases from the use of products

4.4.2.1.1. Nature of the source and relevant pollutants

As products are used everywhere in society, direct releases to air, soil or water may occur anywhere and releases of hazardous substances from the use of products can contribute significantly to national total chemical releases to the environment. Products that contain hazardous chemicals may be labelled with hazard symbols, e.g. impregnation agents, car care products, glues, washing agents, plant protection agents or flammable and explosive products. Environmentally hazardous substances can, however, also be released from products without clear information of their presence. Examples of such products are furniture, electronics, kitchen and washing machinery (white products), textiles, toys, cosmetics and pharmaceuticals.

4.4.2.1.2. Factors affecting releases

Chemical releases from products are known to occur during the normal use of products through various mechanisms and environmental routes. The releases vary depending, for example, on the properties of both the chemical and the product material and how the chemical is bound to the material, on environmental conditions and compartment to which chemicals are released as well as on the use patterns of the product, possible breakdown of the product and wearing.

Even if the release concentration of a chemical is low, the volume of products used may be large. The use volume is affected by the number of products as well as the frequency and duration of the use of the product.

4.4.2.1.3. Description of release estimation techniques

A collection of existing RETs for the use of products is available in the *OECD Resource Compendium on PRTR Release Estimation Techniques, Part IV – Products*.

From the eleven case studies presented in the RC two are related to specific chemicals (lead and nonylphenol and nonylphenoethoxylates) and nine are product group –based:

- Products used in the construction and building sector;
- Electrical and electronic equipment;
- Furniture;
- Nanoproducts;
- Packages and plastic bags;
- Pharmaceuticals, personal care and cleaning products;
- Pesticides;
- Textile and leather products; and
- Toys and low-cost jewellery

In a recent project funded by the Nordic Council of Ministers, Nordic countries developed new or re-evaluated some of the existing RETs²⁴, so that these could be used to include releases from products into national inventories using the following evaluation criteria: the methods need to be suitable for PRTR reporting, the input data to calculations need to be accessible and the releases need to be estimated at a sufficient accuracy level. The provided default RETs are in some cases indeed rough and are recommended to be replaced by more exact national methodologies when these exist. The RETs need to be improved when new data and information becomes available.

Principles for calculation of releases from product use are provided in *OECD Resource Compendium on PRTR Release Estimation Techniques, Part IV – Products, Volume 1, Chapter 7: General introduction to release estimation techniques; Volume 2, Part A, Recommended RETs for PRTR Releases from the use of selected products.*

4.4.2.1.4. Spatial allocation

The spatial allocation of emissions should be based on the spatial distribution of different products, e.g. using population densities and types as much as geographic data will allow.

4.4.2.1.5. Summary of steps in the process

1. Determine whether product use in the study region may be an important source of emissions, assuming these emissions are included in the inventory.
2. Determine the availability of different basis to allocate emissions geographically, e.g. by population densities and other information.
3. According to data available, resources and inventory objectives, decide on the most suitable methodology.
4. Collect the necessary data and estimate emissions, then sum for each pollutant.
5. Spatially and temporally disaggregate as required.

4.4.2.1.6. Comments on reliability

The use of a methodology requires information on national practices and types of products as well as their properties, both for domestic products and imported ones. There is a high level of uncertainty regarding national information as well as current release estimation techniques.

4.4.2.1.7. Sources of further information

- OECD Resource Compendium on PRTR Release Estimation Techniques, Part 4: Summary of Techniques for Estimating Releases of Chemicals from Products, published in 2011 and updated in 2017 [ENV/JM/MONO(2017)2], [ENV/JM/MONO(2017)2/ANN]

²⁴ Copper from boat under seal treatment, copper from fish farming nets (impregnation), DEHP from PVC flooring, ethanol from car care products, heavy metals and NMVOC from plastic bags, PCBs from sealants in building and construction, PAHs from bitumen roofing products, heavy metals from vehicle brake and tyre wear and mercury from various mercury containing products.

- EEA (2016), EMEP/EEA Air Pollutant Emission Inventory Guidebook (European Environment Agency, Copenhagen, Denmark), 2016 Edition. <http://www.eea.europa.eu/publications/emep-eea-guidebook-2016>.

4.5. Summary of Techniques for Agriculture Sources

4.5.1. Agriculture

Two important sources of greenhouse gases emissions, enteric fermentation and manure management (major source of methane and ammonia, respectively) are first described in this section. Then, other sources such as wildfires/agricultural burning (contribute to criteria air pollutants and HAPs), use of fertilizers and pesticides and other sources. Note that this section does not cover other sources such as animal housing due to the limitation in obtaining relevant information.

4.5.1.1. Enteric fermentation

4.5.1.1.1. Nature of the source and relevant pollutants

Enteric fermentation is fermentation that takes place in the digestive systems of animals. In particular, ruminant animals (cattle, buffalo, sheep, goats, and camels) have a large "fore-stomach," or rumen, within which microbial fermentation breaks down food into soluble products that can be utilised by the animal. Approximately 200 species and strains of microorganisms are present in the anaerobic rumen environment, although only a small portion, about 10 to 20 species, are believed to play an important role in ruminant digestion. The microbial fermentation that occurs in the rumen enables ruminant animals to digest coarse plant material that monogastric animals cannot digest.

Methane is produced in the rumen by bacteria as a by-product of the fermentation process. This CH₄ is exhaled or belched by the animal and accounts for the majority of emissions from ruminants. Methane also is produced in the large intestines of ruminants and is expelled.

4.5.1.1.2. Factors affecting releases

There are a variety of factors that affect CH₄ production in ruminant animals, such as: the physical and chemical characteristics of the feed, the feeding level and schedule, the use of feed additives to promote production efficiency, and the activity and health of the animal. It has also been suggested that there may be genetic factors that affect CH₄ production. Of these factors, the feed characteristics and feed rate have the most influence.

4.5.1.1.3. Description of release estimation techniques

The general approach to estimate CH₄ emissions from livestock is to multiply the number of animals by an emissions factor. Thus the basic formula is:

$$\text{CH}_4 \text{ Emissions} = \text{Number of Animals} * \text{CH}_4 \text{ Emissions Factor}$$

The three main steps to estimate methane emissions for livestock are as follows: a) Collect animal population and animal characteristics data; b) Estimate the emissions factor for the animal type; and c) Multiply the emission factor estimate by the population to get the total methane emission estimate for the population. The first two steps can be completed at various levels of detail and complexity.

The emissions factors are an estimate of the amount of methane produced (kg) per animal. Emission factors are based on animal and feed characteristics data. Specifically, the emissions factors are based on the average energy requirement of the animal, the average feed intake to satisfy the energy requirements, and the quality of the feed consumed. There are two methods by which to estimate emissions factors. The Tier 1 method relies on the default emissions factors in the IPCC Guidelines. These emissions factors are highly uncertain because they are not based on country-specific information. The Tier 2 method involves collecting data to calculate the emissions factor. By using the Tier 2 method, uncertainty in the emissions factors is generally lower because these emissions factors are based on country-specific conditions. Tier 1 requires data on the number of animals only, while Tier 2 requires data on the number of animals and on feed and animal characteristics. The feed and animal characteristics collected for Tier 2 are used to calculate the emissions factors.

4.5.1.1.4. Comments on reliability

Given that the emissions factors for Tier 1 are not based on country-specific data, they may not represent accurately the livestock characteristics for each country. The emissions factors are highly uncertain as a result.

The primary source of uncertainty in the Tier 2 emissions factors is the livestock characteristics. The level of confidence in the livestock characteristics data depends on the methods used to collect the data for each country.

4.5.1.1.5. Sources of further information

International

- IPCC (2006), 2006 Intergovernmental Panel on Climate Change Guidelines for National Greenhouse Gas Inventories, Prepared by the National Greenhouse Gas Inventories Programme, Eggleston H.S., Buendia L., Miwa K., Ngara T. and Tanabe K. (eds). Published: IGES, Japan., Volume 4: Agriculture, Forestry, and Other Land Use, Chapter 10, Section 3, page 24, http://www.ipcc-nggip.iges.or.jp/public/2006gl/pdf/4_Volume4/V4_10_Ch10_Livestock.pdf

US

- US EPA (1995-2018), Compilation of Air Pollutant Emission Factors, Volume I, Stationary Point and Area Sources, AP-42 (United States Environmental Protection Agency, North Carolina, US), Chapter 14, Section 4: Enteric Fermentation – Greenhouse Gases, <http://www3.epa.gov/ttnchie1/ap42/ch14/final/c14s04.pdf>

4.5.1.2. Manure management

4.5.1.2.1. Nature of the source and relevant pollutants

Agriculture is the major source of ammonia in many countries. In Europe, animal excreta contributes over 80% of NH₃. It is also a significant source of N₂O, both directly from manure and also following the input of nitrogen from manure to the soil. Methane emissions from manure are less significant than from enteric fermentation in livestock, and NMVOC emissions are relatively minor compared with other sources.

This section deals with animal excreta deposited in buildings and collected as liquid slurry or solid manure. The EMEP/EEA manual deals with emissions from manure in open

paddocks in separate sections (Cultures with Fertilisers and Cultures without Fertilisers). This is because it is difficult to distinguish emissions from urine and manure from those associated with fertilisers and soils only.

4.5.1.2.2. Factors affecting releases

For housed animals, emissions are divided into those directly from animal houses and those associated with subsequent storage and the spreading of wastes. Emissions of NH_3 depend on the types, age and weight of animals, and also on the nitrogen content of feed, housing system, waste storage system, climatic conditions and the amount of time animals spend indoors *versus* outdoors. Emissions of NH_3 after spreading depend on properties of the waste, soil properties, method and rate of application, height of crop, and meteorology.

Emissions of CH_4 depend on the manure management system and contact with oxygen, moisture level and temperature. Emissions of N_2O depend on the composition of the manure and can be also be influenced by manure storage and management, including moisture level and oxygen content. It is difficult to influence emissions from soils following nitrogen input.

4.5.1.2.3. Description of release estimation techniques

In most cases, quantitative data on all of the factors mentioned above will not be available. The simplest method for estimating NH_3 emissions is to use default emission factors, such as those in the EMEP/EEA Guidebook for each animal type, inside housing, outside storage and surface spreading (expressed in kg of NH_3 per animal). Then total emissions are scaled up according to the total number of animals in each class. A more detailed approach would be based on nitrogen flows within a process-based model. For this, country specific information on manure management and animal husbandry would be required. A spreadsheet can be obtained (refer to the Guidebook for details) for calculations, with one table for each animal type, and default values included on volatilisation rates, abatement measure efficiency, nitrogen excretion rates and manure management systems.

The IPCC guidelines provide default N_2O emission factors (expressed in kg of N_2O per kg of N excreted) for different types of animal waste management systems. Data are required on animal types and weights, the fraction of manure produced in waste management systems for each animal type, N excretion for each animal type (default values for the latter are in the EMEP/EEA Guidebook). The Guidebook also has default emission factors for N_2O emissions from soil due to manure input. For these emissions, data on total N excretion by animals are also needed, or default values can be used. No more detailed methods are provided, although country specific data can be used in place of default IPCC values.

Estimating CH_4 releases from manure requires data on animal populations and manure management practices. The IPCC guidelines contain default emission factors (expressed in kg per animal) for each type of animal. A more detailed approach would involve using country specific information on feed intake and waste management systems to derive local emission factors, and would also include more animal sub-categories.

4.5.1.2.4. Spatial allocation

The spatial allocation of any emissions from manure management should be based on the spatial distribution of animal numbers and types as much as geographic data will allow, in particular for NH_3 which may be important in airshed modelling programmes.

4.5.1.2.5. Summary of steps in the process

1. Determine whether housed livestock in the study region may be an important source of emissions, assuming ammonia and/or greenhouse gases are included in the inventory.
2. Determine the availability of activity data including livestock numbers for different classes of animals, geographic distribution, and other information about waste management practices, feed intake etc.
3. According to data available, resources and inventory objectives, decide on the most suitable methodology.
4. Collect the necessary data and estimate emissions for each animal type then sum for each pollutant.
5. Spatially and temporally disaggregate as required.

4.5.1.2.6. Comments on reliability

The use of a simple methodology involving default emission factors for NH₃ for each class of animal will be less accurate than a country specific approach that takes account of different farming situations. There is a high level of uncertainty regarding agricultural emissions of N₂O in general, including emission factors and N excretion. The available emission factors do not account for the effects of soil type, crops or climate on N₂O formation. For NMVOC emissions from manure, the lack of measurement data means there is a significant uncertainty in relation to emissions estimates.

4.5.1.2.7. Sources of further information

Europe

- EEA (2016), EMEP/EEA Air Pollutant Emission Inventory Guidebook (European Environment Agency, Copenhagen, Denmark), 2016 Edition. <http://www.eea.europa.eu/publications/emep-eea-guidebook-2016>.

International

- IPCC (2006), 2006 Intergovernmental Panel on Climate Change Guidelines for National Greenhouse Gas Inventories Prepared by the National Greenhouse Gas Inventories Programme, Eggleston H.S., Buendia L., Miwa K., Ngara T. and Tanabe K. (eds). Published: IGES, Japan. <http://www.ipcc-nggip.iges.or.jp/public/2006gl/>.

US

- US EPA (1999), *Methods for Estimating Greenhouse Gas Emissions from Manure Management*, Chapter 7 from Volume VIII of the EIIP Document Series, prepared by ICF Consulting, US (United States Environmental Protection Agency, North Carolina, US). <https://p2infohouse.org/ref/17/ttn/volume08/viii07.pdf>.

4.5.1.3. Field burning of agricultural waste

4.5.1.3.1. Nature of the source and relevant pollutants

In agricultural areas, stubble, crop residues and other waste are often burnt. A wide range of pollutants are emitted from burning of agricultural areas, including particles, CO, VOCs,

SO₂, NH₃, various HAPs such as dioxins, PAHs and metals. The inefficient form of combustion from fires means that there is relatively little NO_x produced. Fires are also a significant source of greenhouse gases, particularly CO₂, but also CH₄ and N₂O.

The open burning of household and garden wastes and land cleaning debris is not considered here.

4.5.1.3.2. Factors affecting releases

Emissions from the burning of agricultural waste depend on the type of crop burnt, the size of harvest and farming practices. It is not practicable to use abatement methods to control emissions from open burning. The only way of reducing emissions is to reduce the activity. The impacts on adjoining areas may be minimised, however, by avoiding burning on days of adverse meteorology.

Other factors influencing emissions from agricultural burning (but which are not generally factored into release calculation processes) include the stage of burn, fuel loading geography, moisture content and topography.

4.5.1.3.3. Description of release estimation techniques

In the EMEP/EEA Guidebook, Section 3 (relating to the open burning of agricultural wastes) excludes stubble burning but includes other crop residues, timber, leaves, animal carcasses etc. The simplest approach is to use a single emission factor for each pollutant representing emission per mass of waste burned. This requires input data on the amount of waste per hectare of farmland and the total area. The Guidebook includes a default value for the amount of waste per hectare of arable farmland, and some typical emission factors for dioxins, PAHs, VOCs and NH₃/NH₄. Section 3 also includes a brief section on stubble burning which includes an emission factor for NH₃.

A more detailed approach involves estimating the weight of waste per hectare for different types of farming and crops. This requires a more detailed breakdown of crop yields, the residue/crop ratio and the proportion of harvest subject to burning. AP-42 provides emission factors (g/kg) for various types of crops for emissions of particles, CO, CH₄ and VOCs. The Australian NPI manual on prescribed burning and wildfires includes a table of emission factors (g/kg) for agricultural burning for a range of crops. The emission factors provided are derived from both local and US (mostly CARB) sources.

Methods for estimating emissions of greenhouse gases (CH₄, CO₂ and N₂O) from agricultural waste are documented by IPCC. The EIIP report contains an example following several steps. First, the amount of dry matter burnt is calculated. This calculation requires data on crop production rates, residue/crop ratios, the proportion of harvest subject to burning, the dry matter content of residue, burning efficiency and combustion efficiency. Then the total amount of carbon released is estimated and the CH₄ and N₂O emissions are estimated following the calculation of total nitrogen content.

4.5.1.3.4. Spatial allocation

Spatial allocation should be based on the farm area burnt in a given year. If a more detailed method is used, involving the breakdown of emissions into farm/crop types, then spatial allocation should reflect this if the corresponding spatial data are available.

4.5.1.3.5. Summary of steps in the process

1. Determine which forms of agricultural burning are relevant to the study region and the extent of available activity data and local fuel loading values, emission factors and other data.
2. Decide which estimation methods to use and collect the data needed.
3. Calculate emissions for each sub-category, then aggregate as required.
4. Spatially and temporally disaggregate as required.

4.5.1.3.6. Comments on reliability

Activity data on the areas of farmland and crop harvests may be quite good in many countries, but estimates of waste (residue/crop ratios) from crops are often unreliable. Some emission factors (*e.g.* dioxins, PAHs in particular) may have a high degree of uncertainty.

4.5.1.3.7. Sources of further information

Europe

- EEA (2016), EMEP/EEA Air Pollutant Emission Inventory Guidebook (European Environment Agency, Copenhagen, Denmark), 2016 Edition. <http://www.eea.europa.eu/publications/emep-eea-guidebook-2016>.

International

- IPCC (2006), 2006 Intergovernmental Panel on Climate Change Guidelines for National Greenhouse Gas Inventories Prepared by the National Greenhouse Gas Inventories Programme, Eggleston H.S., Buendia L., Miwa K., Ngara T. and Tanabe K. (eds). Published: IGES, Japan. <http://www.ipcc-nggip.iges.or.jp/public/2006gl/>.

US

- US EPA (1995-2018), *Compilation of Air Pollutant Emission Factors, Volume I, Stationary Point and Area Sources*, Chapter 13: Miscellaneous Sources, Section 13.1, Wildfires and Prescribed Burning. AP-42 (United States Environmental Protection Agency, North Carolina, US). <https://www3.epa.gov/ttn/chief/ap42/ch13/final/c13s01.pdf>
- US EPA (1999), *Methods for Estimating Greenhouse Gas Emissions from Burning of Agricultural Crop Wastes*, Chapter 11 from Volume VIII of EIIP Document Series, prepared by ICF Consulting, US (United States Environmental Protection Agency, North Carolina, US). <https://p2infohouse.org/ref/17/ttn/volume08/viii11.pdf>.

4.5.1.4. Use of fertilizers

4.5.1.4.1. Nature of the source and relevant pollutants

Fertilizers are used in the agricultural industry to provide essential nutrients to plants and improve the production of crops. There are 16 essential elements or nutrients supplied from the atmosphere, water, and soil medium that are necessary for plant growth. Three of the 16 elements, carbon, hydrogen, and oxygen are supplied by the atmosphere or water. The

remaining 13 elements, which include nitrogen, phosphorus, potassium, calcium, magnesium, sulphur, copper, zinc, boron, manganese, iron, chlorine, and molybdenum, are supplied through the soil medium. As concentrations of these elements may be limited in soil, fertilizers are added as a supplement.

Fertilizers are found in several forms:

- Gaseous – Anhydrous ammonia is the only gaseous fertilizer used. It is usually stored in liquid form, usually under pressure, and applied by subsurface injection.
- Fluid – Either solutions, free of solid particles, or suspensions, two-phase fertilizers in which solid particles are suspended in the aqueous phase. Fluid fertilizers are sprayed onto the surface of the soil.
- Solid – Solid fertilizers are typically found as straight nitrogen (urea or ammonium nitrate) or mixed fertilizers containing nitrogen and phosphate, potassium, or another nutrient. The solid fertilizers are spread by equipment over the surface of the soil. Although nitrogen fertilizers are applied as a solid, there usually is a sufficient amount of moisture available in the soil or air for the fertilizer to dissolve.

The application of fertilizer generates increased gaseous emissions including NO, N₂O, NH₃, and SO₂. The addition of urea or lime as a fertilizer to soils leads to a loss of CO₂ that was fixed in the industrial production process.

4.5.1.4.2. Factors affecting releases

Ammonia volatilization occurs when ammonium in the fertilizer solution is exposed to the atmosphere. The extent to which NH₃ is emitted to the atmosphere is dependent on the chemical composition, including the concentration of NH₃ of the solution, the temperature of the solution, the surface area of the soil that is exposed to the atmosphere, and the resistance of NH₃ transport in the atmosphere.

The pH level of the soil will impact volatilization of NH₃ from nitrogen fertilizers. Higher pH favours volatilization of NH₃ from nitrogen fertilizers, so acidic soil (lower pH) will have lesser volatilization while alkaline soil (higher pH) will have a larger potential for volatilization. However, the strong interaction between the soil and fertilizer can override the effects of soil pH on volatilization.

Fertilizers that only contain nitrogen as nitrate are not direct sources of NH₃, but can increase NH₃ emissions through the increase in the concentration of nitrogen in the leaves of crops following the addition of nitrogen fertilizers. Emissions from the crop canopy occur 7 to 10 days after nitrogen fertilizer application and are included in the nitrogen fertilizer emissions since they cannot be distinguished from emissions directly from applied nitrogen fertilizer.

Reductions in nitrogen emissions, including those of NH₃ and NO, can occur when it is ensured that the applications of nitrogen fertilizers are no greater than are needed for optimum crop yield. Ammonia emissions from urea can be reduced by rapid incorporation of urea immediately after application; however, in crops of cereals or grass, incorporation is rarely a practical option. It can be more cost effective and reduce NH₃ emissions to apply an alternate nitrogen fertilizer than urea when conditions allow. Ammonia emissions can also be reduced by the use of a fertilizer granule in the soil at seed depth. Applying nitrogen fertilizers when the weather is cool and moist or just prior to rainfall will reduce NH₃ emissions.

Adding carbonate lime to soil (in the form of calcic limestone (CaCO_3) or dolomite ($\text{CaMg}(\text{CO}_3)_2$)) emits CO_2 as the carbonate lime dissolves and releases bicarbonate, which evolves into CO_2 and water.

Urea ($\text{CO}(\text{NH}_2)_2$) is converted into ammonium (NH_4^+), hydroxyl ion (OH^-), and bicarbonate (HCO_3^-), in the presence of water and urease enzymes. Similar to the addition of lime to soil, bicarbonate is formed after the addition of urea and evolves into CO_2 and water.

4.5.1.4.3. Description of release estimation techniques

The NH_3 and NO emissions from nitrogen fertilizers are estimated using the following Tier 1 equation:

$$E_{\text{pollutant}} = \text{AR}_{\text{fertiliser_applied}} \cdot \text{EF}_{\text{pollutant}}$$

where:

$E_{\text{pollutant}}$ = amount of pollutant emitted (kg a^{-1}),

$\text{AR}_{\text{fertiliser_applied}}$ = amount of N applied (kg a^{-1}),

$\text{EF}_{\text{pollutant}}$ = EF of pollutant (kg kg^{-1}).

This equation is applied at the national level, using annual national total fertilizer nitrogen use. The Tier 1 default NH_3 emission factor is derived from a mean of default emission factors for individual nitrogen fertilizers weighted based on their use according to a report by IFA for Europe in 2014. The emission factor for NH_3 from nitrogen fertilizer is $0.05 \text{ kg NH}_3 \text{ kg}^{-1}$ fertilizer applied and the emission factor for NO from nitrogen fertilizer is 0.04 kg kg^{-1} fertilizer applied, reported as NO_2 .

The CO_2 emissions from urea fertilizers are estimated using the following Tier 1 equation:

$$\text{CO}_2\text{-C Emission} = M \times \text{EF}$$

where:

$\text{CO}_2\text{-C Emission}$ = annual C emissions from urea application, tonnes C yr^{-1}

M = annual amount of urea fertilisation, tonnes urea yr^{-1}

EF = emission factor, tonne of C (tonne of urea) $^{-1}$

An overall emission factor of 0.20, the equivalent to the carbon content of urea on an atomic weight basis, for urea is applied. Multiply the $\text{CO}_2\text{-C}$ emissions by 44/12 to convert into CO_2 .

The CO_2 emissions from additions of carbonate limes to soil are estimated using the following Tier 1 equation:

$$\text{CO}_2\text{-C Emission} = (M_{\text{Limestone}} \times \text{EF}_{\text{Limestone}}) + (M_{\text{Dolomite}} \times \text{EF}_{\text{Dolomite}})$$

where:

$\text{CO}_2\text{-C Emission}$ = annual C emissions from lime application, tonnes C yr^{-1}

M = annual amount of calcic limestone (CaCO_3) or dolomite ($\text{CaMg}(\text{CO}_3)_2$), tonnes yr^{-1}

EF = emission factor, tonne of C (tonne of limestone or dolomite) $^{-1}$

An overall emission factor of 0.12 for limestone and 0.13 for dolomite, the equivalents to carbonate carbon contents of the materials, is applied. Multiply the CO₂-C emissions by 44/12 to convert into CO₂.

The gridding of national emissions to regional or local levels is accomplished using proxy variables for spatial distribution of nonpoint emissions from the agricultural sector. For example, national emissions in Europe from fertilizer can be allocated to the regional or local levels using land cover types from the CORINE Land Cover database (EC, 2011^[25]).

Emissions to water in the European River Basin Districts are allocated using results from JRC's GREEN model for Nutrient-N and Nutrient-P. Only nutrient emissions, i.e. fertilizer applications, are used in this project. Nutrient inputs from agriculture are estimated based on the CORINE Land Cover map and fertiliser rate by NUTS2 region and crop type. Activity rates and emission factors are both taken into account in the model calculations. Emissions from agriculture to surface water using this method are then spatially allocated to RBDSU spatial level using GIS techniques. Proxy data used for spatial allocation are land use data, fertilizer application rates from CAPRI, and population statistics (EC, 2013^[26]).

4.5.1.4.4. Comments on reliability

The inventory compiler should review emission factors, direct measurements, and activity data and compare to country-specific data and factors for nitrogen and urea fertilizers.

The main uncertainty in the emissions calculations for fertilizer is in the emission factor and not the area of crops under cultivation which is probably accurate to better than ± 10 percent in most countries. The application of nitrogen fertilizer may be estimated with an accuracy of ± 10 percent.

The overall emissions in the NH₃ measurements from mineral fertilizer are no better than ± 50 percent and the standard deviation in the NH₃ measurements from mineral fertilizer are at the same level as the average measured emission in percent.

For NO emission estimates, the relative 95 percent-confidence interval may be regarded as from -80 percent to +406 percent. Therefore, the overall uncertainty may be considered to be a factor of four.

For CO₂ emissions from urea or liming, there are uncertainties in the amount of urea or lime applied to soils and in the net amount of carbon from urea or liming that is emitted as CO₂. The emission factors for urea and lime have an uncertainty of -50 percent.

The reliability of activity data will depend on the accuracy of production, sales, import/export, and/or usage data. Since the import/export and production data have additional uncertainties due to inferences about application, inventory compilers may use a conservative approach and assume that all urea or lime available for application or purchased is applied to soils. Assuming there is no long-term stockpiling of urea or lime fertilizer, the over- or under-estimates from this approach will be negligible on the longer-term outlook.

There are uncertainties in the net amount of carbon added to soils from urea or lime fertilization that is emitted as CO₂. For the Tier 1 methodology a conservative approach is taken and it is assumed that all carbon in the urea or lime is lost as CO₂. However, it is possible in practice that some of the carbon in urea or lime may be retained in the soil as inorganic carbon and not emitted to the atmosphere as CO₂ during the application year.

Uncertainties in emissions from application of urea or lime fertilizer can also arise from insufficient data on site characteristics, hydrology, and other environmental variables which influence the transport and conversion of inorganic C into CO₂ or insufficient knowledge of the processes and/or the ability of country-specific emission factors or estimation systems to represent the fate of the carbon in urea or lime.

4.5.1.4.5. Sources of further information

Canada

- Environment Canada (2013), Manual for the Compilation of Canada's 2013 Air Pollutant (Environment Canada, Ottawa, Canada). http://publications.gc.ca/collections/collection_2013/ec/En14-87-2013-eng.pdf.

Europe

- EEA (2016), EMEP/EEA Air Pollutant Emission Inventory Guidebook (European Environment Agency, Copenhagen, Denmark), 2016 Edition. <http://www.eea.europa.eu/publications/emep-eea-guidebook-2016>.
- EC (2011), Methodology development for the spatial distribution of the diffuse emissions in Europe, (European Commission, European Union, Luxembourg) https://www.eea.europa.eu/data-and-maps/data/european-pollutant-release-and-transfer-register-e-prtr-regulation-art-8-diffuse-air-data/methodology-report/diffuse_releases_e-prtr_methodology_2011_en.pdf.
- EC (2013), Diffuse water emissions in E-PRTR, (European Commission, European Union, Luxembourg), [http://fis.freshwatertools.eu/files/MARS_resources/Info_lib/Deltares\(2013\)Diffus e%20water%20emissions%20in%20E-PRTR%202013%20project%20report.pdf](http://fis.freshwatertools.eu/files/MARS_resources/Info_lib/Deltares(2013)Diffus e%20water%20emissions%20in%20E-PRTR%202013%20project%20report.pdf).

International

- IPCC (2006), 2006 Intergovernmental Panel on Climate Change Guidelines for National Greenhouse Gas Inventories Prepared by the National Greenhouse Gas Inventories Programme, Eggleston H.S., Buendia L., Miwa K., Ngara T. and Tanabe K. (eds). Published: IGES, Japan. <http://www.ipcc-nggip.iges.or.jp/public/2006gl/>.

US

- US EPA (1995-2018), *Compilation of Air Pollutant Emission Factors, Volume I, Stationary Point and Area Sources*, Chapter 9: Food and Agricultural Industries, Section 9.2.1, Fertilizer Application. AP-42 (United States Environmental Protection Agency, North Carolina, US). <https://www3.epa.gov/ttn/chief/ap42/ch09/draft/d09s0201.pdf>

4.5.1.5. Use of pesticides

4.5.1.5.1. Nature of the source and relevant pollutants

Emissions may arise following the application of pesticides either from volatilization of pesticides deposited to leaf or soil prior to uptake by the crop or soil, or from 'spray drift', the movement of fine droplets of pesticide spray away from the target application zone to areas downwind.

4.5.1.5.2. Factors affecting releases

Pesticide emissions from the agricultural use of pesticides are potentially influenced by:

- the way in which a pesticide is applied;
- whether or not application takes place in closed spaces (greenhouses);
- the vapour pressure of the pesticide involved;
- additives used with pesticides in order to increase their uptake;
- the meteorological conditions during application; and
- the height of the crop.

In order to calculate pesticide emissions precisely, it would be necessary to have quantitative data on all the factors noted above. In practice, these data are not available, and even data on the way in which pesticides are applied are scarce and mostly unreliable. Therefore, the methodology presented here assumes that application takes place under normal field conditions (i.e. no specific measures taken to avoid emissions), with a standard meteorology.

4.5.1.5.3. Description of release estimation techniques

The emission is estimated from the amount of the pesticide applied and an EF as:

$$E_{\text{pest}} = \sum m_{\text{pest}_i} \cdot EF_{\text{pest}_i}$$

where:

E_{pest} = total emission of pesticides (in $t a^{-1}$),

m_{pest} = mass of individual pesticide applied ($t a^{-1}$),

EF_{pest} = EF for individual pesticide ($kg kg^{-1}$).

The EFs are derived from the vapour pressure of the pesticides. Vapour pressure is currently the most convenient way to estimate emissions. Other estimates may take into account Henry coefficients or other parameters, but there are not enough data available to make more reliable EFs.

The use of pesticides can be estimated by three approaches, depending upon which data are available. It is not necessary to follow the same procedure for different pesticides for one specific country when the required data are not available. The three approaches are when consumption is known for individual pesticides, when totals of pesticide consumption are known and when no consumption data are available. Once activity is known or estimates, then the total emission of a specific pesticide is calculated by multiplying the total use and the EF.

4.5.1.5.4. Comments on reliability

The quality of emission estimates of pesticide use will vary considerably from country to country, depending largely on the quality of the information regarding the types and amounts of pesticides used.

Uncertainties in pesticide emissions are in the magnitude of a factor of 2–5. There are reliable EFs for only a few compounds (about 15). The EFs for the other compounds are derived by extrapolation or from few measurements.

Data on the use of pesticides are scarce and unreliable for most countries. When these data are available, they are not always available for research groups. Making these figures public would be an easy way to get a major improvement in emission estimates.

4.5.1.5.5. Sources of further information

Europe

- EEA (2016), EMEP/EEA Air Pollutant Emission Inventory Guidebook (European Environment Agency, Copenhagen, Denmark), 2016 Edition. <http://www.eea.europa.eu/publications/emep-eea-guidebook-2016>.

US

- US EPA (1995-2018), *Compilation of Air Pollutant Emission Factors, Volume I, Stationary Point and Area Sources*, Chapter 9: Food and Agricultural Industries, Section 9.2.2, Pesticide Application. AP-42 (United States Environmental Protection Agency, North Carolina, US). <https://www3.epa.gov/ttn/chief/ap42/ch09/final/c9s02-2.pdf>

4.5.1.6. Agriculture Other (Ammonia-treated straw)

4.5.1.6.1. Nature of the source and relevant pollutants

The most common method of treatment is to enclose straw bales in plastic and then inject anhydrous NH₃ into the bales. The treated straw is then left for a number of weeks, to allow the chemical reaction between the NH₃ and straw to proceed. The plastic is removed several days before the straw is to be fed to the livestock, to allow excess NH₃ to dissipate.

4.5.1.6.2. Factors affecting releases

The emission of NH₃ depends on the NH₃ application rate and the extent to which the NH₃ combines chemically with the straw. The latter depends on the gas tightness of the plastic wrapping, the ambient temperature and the length of the maturation process. An application rate of 30–35g (kg DM)⁻¹ NH₃ is commonly used and a maturation time of four to six weeks is allowed, dependent on ambient temperature.

4.5.1.6.3. Description of release estimation techniques

The emission is estimated from the amount of NH₃ applied and an EF as:

$$E_{\text{straw}} = m \cdot EF_{\text{straw}}$$

where:

$$E_{\text{straw}} = \text{total emission of NH}_3 \text{ (in t a}^{-1}\text{),}$$

$$m = \text{mass of NH}_3 \text{ used (t a}^{-1}\text{),}$$

$$EF_{\text{straw}} = \text{EF for NH}_3 \text{ treated straw (t t}^{-1}\text{).}$$

No published measurements of the emission of NH₃ from the NH₃ treatment of straw are available. However, 30–35 g (kg DM straw)⁻¹ NH₃ is commonly used, equivalent to 25–28 g (kg DM straw)⁻¹ NH₃-N. This means that about 46 % of the NH₃ is retained in the straw and 54 % is lost to the atmosphere. It is assumed here that the nitrogen is lost as NH₃, so the value of E_{straw} is 0.54.

4.5.1.6.4. Comments on reliability

The mass balance approach used to estimate the emission factor for NH₃ treated straw is considered robust, although there is no direct evidence that the nitrogen lost is emitted as NH₃ (rather than nitrous oxide, nitric oxide or dinitrogen gasses). No systematic survey of treatment practices has been conducted. However, operators have an economic incentive to optimise the process, so it is considered that the uncertainty in the emission factor is 15-25 %.

Since the emission of NH₃ from NH₃-treated straw has only recently been included as a source, there is at present no basis for assessing the uncertainty of the activity data.

4.5.1.6.5. Sources of further information

Europe

- EEA (2016), EMEP/EEA Air Pollutant Emission Inventory Guidebook (European Environment Agency, Copenhagen, Denmark), 2016 Edition. <http://www.eea.europa.eu/publications/emep-eea-guidebook-2016>.

4.6. Summary of Techniques for Land Use and Forestry Sources

4.6.1. Forestry

Prescribed wildfires are an important source of greenhouse gases. In addition, fires contribute to criteria air pollutants and HAPs.

4.6.1.1. Wildfires, prescribed

4.6.1.1.1. Nature of the source and relevant pollutants

Forest burning includes prescribed burns for various purposes such as fuel reduction and ecosystem management, plus wildfires that are the result of arson or occur naturally. A wide range of pollutants are emitted from burning of forests, including particles, CO, VOCs, SO₂, NH₃, various HAPs such as dioxins, PAHs and metals. The inefficient form of combustion from fires means that there is relatively little NO_x produced. Fires are also a significant source of greenhouse gases, particularly CO₂, but also CH₄ and N₂O.

The open burning of household and garden wastes and land cleaning debris is not considered here.

4.6.1.1.2. Factors affecting releases

Emissions from prescribed burning and wildfires are also highly variable, depending on the type of fuel and loading. Emissions are also likely to vary greatly from one year to the next according to variations in the amount of fuel, the areas burnt and the prevailing climatic conditions.

Other factors influencing emissions from forest burning (but which are not generally factored into release calculation processes) include the stage of burn, fuel loading geography, moisture content and topography.

4.6.1.1.3. Description of release estimation techniques

Section 11 of the EMEP/EEA Guidebook includes a chapter on forests and other vegetation fires. A simple method for estimating emissions for five vegetation types involves multiplying the area burnt by emission factors (such as a default factor), which are expressed in kilogrammes/hectare (kg/ha). A more detailed method involves first estimating emissions of carbon, then estimating emissions of other gases using emission ratios with respect to carbon. An algorithm is provided to estimate the mass of carbon emitted (which depends on the area burnt), average biomass of fuel per unit area, fraction of above ground biomass, and the burning efficiency of above ground biomass. Some default values for the last three variables are given, based on European results. Input data on the area burnt must be used; other data should preferably be derived from local information.

The Australian NPI Handbook provides some local fuel loading values for forest wildfires, forest prescribed burning and grassland burning. This relatively simple method requires data on area burnt (ha), fuel loading (kg/ha) and emission factors (expressed in g/kg). Fuel loading and emission factors are provided for three types of fires, namely forest wildfires, prescribed forest burning and grassland.

The US EPA AP-42 provides fuel loading factors for different vegetation types and emission factors (kg/ha) for wildfires in the US. Prescribed burning emission factors (g/kg) are also provided for different vegetation types. These emission factors need to be used in conjunction with local fuel loading values.

4.6.1.1.4. Spatial allocation

Spatial allocation should be based on the areas of forests burnt in a given year. If a more detailed method is used, then spatial allocation should reflect this if the corresponding spatial data are available.

4.6.1.1.5. Summary of steps in the process

1. Determine which forms of forest are relevant to the study region and the extent of available activity data and local fuel loading values, emission factors and other data.
2. Decide which estimation methods to use and collect the data needed.
3. Calculate emissions for each sub-category, then aggregate as required.
4. Spatially and temporally disaggregate as required.

4.6.1.1.6. Comments on reliability

Emission factors for forest burning are associated with a high degree of uncertainty – even more for trace gases than for CO₂ and the common pollutants. Data on areas burnt and timing are likely to be reliable. The quality of fuel load data will depend on the source and how the data have been derived.

4.6.1.1.7. Sources of further information

Australia

- Environment Australia (1999), Emissions Estimation Technique Manual for Aggregated Emissions from Bush Fires and Prescribed Burning (Environment Australia, Canberra, Australia).

<http://www.npi.gov.au/system/files/resources/cf3d7ecb-b57f-70d4-e976-03cb241c888e/files/burningff.pdf>.

Europe

- EEA (2016), EMEP/EEA Air Pollutant Emission Inventory Guidebook (European Environment Agency, Copenhagen, Denmark), 2016 Edition. <http://www.eea.europa.eu/publications/emep-eea-guidebook-2016>.

International

- IPCC (2006), 2006 Intergovernmental Panel on Climate Change Guidelines for National Greenhouse Gas Inventories Prepared by the National Greenhouse Gas Inventories Programme, Eggleston H.S., Buendia L., Miwa K., Ngara T. and Tanabe K. (eds). Published: IGES, Japan. <http://www.ipcc-nggip.iges.or.jp/public/2006gl/>.

US

- US EPA (1995-2018), *Compilation of Air Pollutant Emission Factors, Volume I, Stationary Point and Area Sources*, Chapter 13: Miscellaneous Sources, Section 13.1, Wildfires and Prescribed Burning. AP-42 (United States Environmental Protection Agency, North Carolina, US). <https://www3.epa.gov/ttn/chief/ap42/ch13/final/c13s01.pdf>

4.7. Summary of Techniques for Other natural sources

4.7.1. Other natural sources

4.7.1.1. Geothermal activities

4.7.1.1.1. Nature of the source and relevant pollutants

Emissions from geothermal activities, both eruptive and non-eruptive, include not only volcanoes, but also fumaroles, geysers, metamorphic degassing or other activities related to molten magma in the earth's crust. Heated magma under pressure contains gases like sulphur dioxide, carbon dioxide, hydrogen sulphide, mercury and chlorine. These gases may be released when magma gets close to the surface and pressure is discharged.

With respect to the different sources, non-eruptive volcanoes that outgas at relatively constant rates seem to be more important than those from sporadic eruptions, both for CO₂ and SO₂.

Volcanoes release considerable fluxes of gases and particles to the atmosphere, both during eruptions and by long-term noneruptive degassing. The most important species released directly from magma at high temperatures are SO₂, H₂O, CO₂; trace constituents include HCl, HF, Hg, CuCl etc. Volcanic emissions also include species produced in the extreme environments associated with the volcano. Observations of NO_x flux associated with volcanic activity suggest that this is the result of thermal oxidation of NO formed via reaction of N₂ (from the atmosphere as well as magmatic sources) and O₂ (from the atmosphere), followed by rapid oxidation of the product NO.

Particulate emissions may originate from:

- pyroclastic material (tephra);

- condensation of volcanic gases, as they cool;
- transformation of existing particles; and
- low-temperature reactions (gas-to-particle reactions at ambient temperature and aqueous phase reactions).

Methane emissions from geothermal reservoirs originate through bacterial and thermal decomposition of organic matter, as well as inorganic synthesis (Fischer-Tropsch type: $\text{CO}_2 + 4\text{H}_2 = \text{CH}_4 + 2\text{H}_2\text{O}$) and outgassing from the mantle.

4.7.1.1.2. Factors affecting releases

The volcanic emission patterns and eruption temperature impact emissions. Outgassing may occur continuously or be episodic in the course of an eruption.

4.7.1.1.3. Description of release estimation techniques

The Volcanic Sulphur dioxide Index (VSI) is used to estimate SO_2 emissions from explosive volcanism. In contrast to the Volcanic Explosivity Index (VEI), the VSI relates directly to the amount of volcanic SO_2 produced. It is scaled to be as compatible as possible with the VEI, and allows for differentiation between arc and non-arc volcanoes.

For explosive emissions, the following relationship has been developed:

$$\log E = -0.25 + 0.76 \text{ VEI}$$

where:

E is emission amount of SO_2 (kt),

VEI is the volcanic explosivity index.

It only applies to arc volcanoes. For non arc-volcanoes, emitted SO_2 is typically much higher and less dependent on the VEI. It is good practice to assume an order of magnitude higher emission for eruptions of non-arc volcanoes, using the same formula as for arc volcanoes. The uncertainty is very high, however.

The Smithsonian Global Volcanism Network²⁵ provides information for each volcanic eruption during the past 200 years, as well as dates and explosive magnitudes of large eruptions during the Holocene (the last 10,000 years). A value for the Volcanic Explosivity Index is reported for each singular eruption. For each volcano, descriptions of the volcanic activity are also available, through monthly and weekly reports.

4.7.1.1.4. Comments on reliability

Surrogate parameters to establish emission factors are rather weak. Validation of Cospec measurements through TOMS data and petrologic estimates for assessing eruptive emissions is needed. Available measurements do not allow generalization of ratios to SO_2 -S for other S compounds and other trace species. This applies, in particular, to metal/sulphur ratios, which vary not only from volcano to volcano, but also temporally and spatially at any site, thus showing decoupling of the metal-rich particulate phase from the S-rich gas phase. Volcanic plume geochemical studies in the past have tended to focus on the measurement of composition and emission rates of gases. In order to improve our

²⁵ <http://volcano.si.edu/>

understanding of volcanic particles emissions, future field experiments should aim at characterising the size-resolved chemistry of aerosol, gas particle interactions between plume constituents and the ambient atmosphere (including rural and urban atmospheres, and transport and deposition of both gaseous and particulate volcanogenic components).

4.7.1.1.5. Sources of further information

Europe

- EEA (2016), EMEP/EEA Air Pollutant Emission Inventory Guidebook (European Environment Agency, Copenhagen, Denmark), 2016 Edition. <http://www.eea.europa.eu/publications/emep-eea-guidebook-2016>.

4.7.2. Other activities

The EMEP EEA Emission Inventory Guidebook contains additional emission estimation techniques and should be consulted for more information on the following sources:

- Non-managed and managed forests;
- Natural grassland and other vegetation;
- Wetlands and waters;
- Animals;
- Geological seepage;
- Forest and grassland soils;
- Lightning;
- Changes in forest and other woody biomass stock;
- Forest and grassland conversion;
- Abandonment of managed land; and
- CO₂ emissions from or removal into soil.

4.8. Summary of Techniques for Waste Handling

Five categories are considered here: composting, cremation, open burning, wastewater handling, and municipal solid waste.

4.8.1. Composting

4.8.1.1.1. Nature of the source and relevant pollutants

The source category for the biological treatment of waste in the form of composting is not considered to be significant on a national level for any pollutant. In many areas organic domestic waste is gathered separately. Composting the organic waste produces a reusable product. Emissions to air from this source category include odours. In addition, small amounts of ammonia are produced.

Composting is an aerobic process and a large fraction of the degradable organic carbon (DOC) in the waste material is converted into CO₂. CH₄ is formed in anaerobic sections of the compost, but it is oxidised to a large extent in the aerobic sections of the compost. The

estimated CH₄ released into the atmosphere ranges from less than 1 percent to a few percent of the initial carbon content in the material. Composting can also produce emissions of N₂O. The range of the estimated emissions varies from less than 0.5 percent to 5 percent of the initial nitrogen content of the material. Poorly working composts are likely to produce more of both CH₄ and N₂O.

4.8.1.1.2. Factors affecting releases

Maintaining an aerobic process is important in controlling emissions. This is done mainly by an appropriate supply of oxygen via aeration. Temperature of the treated waste is monitored during the composting to check the operation status.

4.8.1.1.3. Description of release estimation techniques

No Tier 1 emission factors are provided for this source category, emission factors have been defined at a Tier 2 level. A description of the Tier 2 methodology can be found in Chapter 5.B.1 of the 2016 EMEP/EEA Air Pollutant Emission Inventory Guidebook.

The 2006 IPCC Guidelines for National Greenhouse Gas Inventories provide emission estimation techniques for CH₄ and N₂O at the Tier 1 and Tier 2 level. Consult Volume 5, Chapter 4 for more information.

4.8.1.1.4. Spatial allocation

National emissions should be disaggregated on the basis of composting locations, employment or population statistics.

4.8.1.1.5. Summary of steps in the process

1. Identify activity data for composting.
2. Calculate total emissions by combining activity data, emission factors (adjusted if necessary) and any other data required.
3. Spatially and temporally disaggregate as required.

4.8.1.1.6. Comments on reliability

The uncertainty in activity data will depend on how the data are collected. Uncertainties in country-specific emission factors will depend on the sampling design and measurement techniques used to determine the emission factors.

4.8.1.1.7. Sources of further information

Europe

- EEA (2016), EMEP/EEA Air Pollutant Emission Inventory Guidebook (European Environment Agency, Copenhagen, Denmark), 2016 Edition. <http://www.eea.europa.eu/publications/emep-eea-guidebook-2016>.

International

- IPCC (2006), 2006 Intergovernmental Panel on Climate Change Guidelines for National Greenhouse Gas Inventories Prepared by the National Greenhouse Gas Inventories Programme, Eggleston H.S., Buendia L., Miwa K., Ngara T. and

Tanabe K. (eds). Published: IGES, Japan. <http://www.ipcc-nggip.iges.or.jp/public/2006gl/>.

4.8.2. Cremation

4.8.2.1.1. Nature of the source and relevant pollutants

Cremation includes the incineration of human bodies in a crematorium and animal carcass incineration. The contribution of emissions from the incineration of carcasses to the total national emissions is thought to be relatively insignificant (i.e. less than 1 percent of the national emissions of any pollutant). The contribution of crematoria to national emissions is comparatively small for all pollutants except for metals, especially mercury, in certain countries. The contribution of this source category to the total emissions of dioxins and furans is reported to be 0.2 percent. Crematoria also have the potential to emit polycyclic aromatic hydrocarbons (PAHs), but are unlikely to release significant emissions of other persistent organic pollutants (POPs).

There are two main types of crematoria depending on the type of support fuel: crematoria using gas or oil as support fuel and crematoria using electricity as the support fuel. Crematories are usually designed with a primary and a secondary combustion chamber. The crematories are usually single-ended units which process one coffin at a time. The primary chamber has burners that are focused on the coffin and air lances to break up the remains and promote combustion. The combustion gases from the primary chamber are then fed by a series of ducts into the compartmentalised secondary chamber, which is heated with afterburners and supplied with secondary air to complete combustion and reduce the emissions of carbon-based particulate matter (PM), volatile organic compounds (VOCs), and POPs.

Following the cooling period, all non-combustible matter is separated and removed from the bone fragments by visible and/or magnetic separation. This non-combustible matter will be disposed of by the crematorium in a non-recoverable manner. The bone particles removed from the chamber vary in size and shape and may be mechanically processed to reduce them to a manageable consistency for placement into an urn. Ashes are generally mechanically processed to have a more uniform texture and appearance. The incidental fugitive emissions from this processing are negligible.

The major emissions from crematories are nitrogen oxides, carbon monoxide, sulphur dioxide, particulate matter, mercury, non-methane volatile organic compounds (NMVOCs), other metals, and some POPs. The emission rates depend on the design of the crematory, combustion temperature, gas retention time, duct design, duct temperature and any control devices.

Particulates such as dust, soot, ash and other unburned particles originate from the cremation container, human remains, and other contents of the container. Carbon-based organic particulates should be removed in the secondary combustion chamber and through proper adjustment and operation of the cremation equipment. Carbon monoxide results from the incomplete combustion of the container, human remains, fuel, and other contents. Sulphur dioxide is produced from the combustion of fossil fuels, container, and contents. Nitrogen oxides are formed by high temperature combustion processes through the reaction of the nitrogen in air with oxygen. Nitrogen oxide emissions from crematories are low and are not of major concern. Mercury emissions originate from the dental fillings that may contain 5 to 10 grams of mercury depending on the numbers and types used. NMVOCs are produced from incomplete or inefficient combustion of hydrocarbons contained in the

fuels, body, and casket. Dioxins and furans result from the combustion of wood cellulose, chlorinated plastics, and the correct temperature range. Dioxins and furans may be reduced through reduction in the chlorinated plastics and with sufficiently high temperature and residence time in the secondary combustion chamber.

4.8.2.1.2. Factors affecting releases

Carbon monoxide may be minimised through proper adjustment and operation of the cremation equipment. Control of nitrogen oxides can be achieved through temperature control and burner design. Mercury may be removed through the use of selenium salt in the cremation chamber. In some countries, the use of plastic or other types of fillings are gaining popularity which will reduce the mercury emissions. NMVOCs are reduced through the proper use and adjustment of the crematory. Reformation of dioxins and furans can be avoided by good design of the flue-gas ducts, by reducing particulate deposition and avoiding the dioxin and furan reformation temperature window.

Most contaminants except for the metals can be minimised through the proper operation of the crematory in conjunction with adequate temperature and residence time in the secondary combustion chamber. Sulphur oxide may be minimised through the use of low sulphur fuels such as natural gas. Metals except for mercury may be removed through particulate control devices. Mercury can be removed by adding activated carbon to the particulate control devices e.g. bag filters. Emissions may be further reduced through the use of different types of containers such as fibreboard and cloth-covered fibreboard instead of the traditional finished wood. With respect to incineration of animal carcasses, the disposal of animal carcasses by methods such as to a licensed incinerator or landfill site is likely to cause significantly less pollution.

4.8.2.1.3. Description of release estimation techniques

The NO_x, CO, NMVOC, SO₂, TSP, PM₁₀, PM_{2.5}, Pb, Cd, Hg, As, Cr, Cu, Ni, Se, Zn, PCBs, PCDD/F, benzo(a)pyrene, benzo(b)fluoranthene, benzo(k)fluoranthene, indeno(1,2,3-cd)pyrene, and HCB emissions from cremation are estimated using the following Tier 1 equation:

$$E_{\text{pollutant}} = AR_{\text{production}} \times EF_{\text{pollutant}}$$

where:

$E_{\text{pollutant}}$ = the emission of the specified pollutant

$AR_{\text{production}}$ = the activity rate for other metal production

$EF_{\text{pollutant}}$ = the emission factor for this pollutant

The Tier 1 emission factors assume an averaged or typical technology and abatement implementation in the country. The emission factors are based on a 55–70 kg body, about 65 kg on average and are for the uncontrolled cremation. Emissions associated with fuel combustion during the cremation are also included in the emission factors. The fuel basis for the cremation emission factors is assumed to be natural gas. The emission factors, as provided in the 2016 EMEP/EEA Air Pollutant Emission Inventory Guidebook, are: 0.825 kg/body for NO_x; 0.140 kg/body for CO; 0.013 kg/body for NMVOC; 0.113 kg/body for SO₂; 38.56 g/body for TSP; 34.70 g/body for PM₁₀; 34.70 g/body for PM_{2.5}; 30.03 mg/body for Pb; 5.03 mg/body for Cd; 1.49 g/body for Hg; 13.61 mg/body for As; 13.56 mg/body for Cr; 12.43 mg/body for Cu; 17.33 mg/body for Ni; 19.78 mg/body for Se; 160.12 mg/body for Zn; 0.41 mg/body for PCBs; 0.027 µg/body for PCDD/F; 13.20 µg/body for

benzo(a)pyrene; 7.21 µg/body for benzo(b)fluoranthene; 6.44 µg/body for benzo(k)fluoranthene; 6.99 µg/body for indeno(1,2,3-cd)pyrene; and 0.15 mg/body for HCB.

4.8.2.1.4. Spatial allocation

Crematoria are mainly found in larger cities; therefore, the emissions may be prorated using population statistics.

4.8.2.1.5. Summary of steps in the process

1. Identify activity data for cremation.
2. Calculate total emissions by combining activity data, emission factors (adjusted if necessary) and any other data required.
3. Spatially and temporally disaggregate as required.

4.8.2.1.6. Comments on reliability

Emission factors have a very high uncertainty, due to the limited testing data available. There is a very high uncertainty in the emission factors from cremation, which is affected by the high variability in the operating temperatures; the residence time in the secondary combustion chamber; and the fuels used (fuel oils in Sweden, natural gas in North America). Large uncertainties and differences may also be caused by different fuels, design characteristics or due to the limited testing performed to derive the emission factors. Especially emissions of mercury can show extremely high variations. Emissions of mercury are directly related to the number and types of dental filling present in the body incinerated. Metal fittings and fastenings on the caskets can affect the emissions of other metals.

4.8.2.1.7. Sources of further information

Canada

- Environment Canada (2013), Manual for the Compilation of Canada's 2013 Air Pollutant (Environment Canada, Ottawa, Canada). http://publications.gc.ca/collections/collection_2013/ec/En14-87-2013-eng.pdf

Europe

- EEA (2016), EMEP/EEA Air Pollutant Emission Inventory Guidebook (European Environment Agency, Copenhagen, Denmark), 2016 Edition. <http://www.eea.europa.eu/publications/emep-eea-guidebook-2016>.

4.8.3. Open burning

4.8.3.1.1. Nature of the source and relevant pollutants

Open burning is the volume reduction of small-scale agricultural waste. Open burning of waste can be defined as the combustion of unwanted combustible materials such as paper, wood, plastics, textiles, rubber, waste oils and other debris in nature (open-air) or in open dumps, where smoke and other emissions are released directly into the air without passing through a chimney or stack. Open burning can also include incineration devices that do not control the combustion air to maintain an adequate temperature and do not provide sufficient residence time for complete combustion. This waste management practice is used

in many developing countries while in developed countries open burning of waste may either be strictly regulated, or otherwise occur more frequently in rural areas than in urban areas.

Open burning does not include stubble burning or forest fires, which are both covered in other sections. Examples of agricultural wastes that might be burned are crop residues (e.g. cereal crops, peas, beans, soya, sugar beet, oil seed rape etc.), wood, prunings, slash, leaves, plastics and other general wastes. Straw and wood are often used as the fuel for the open burning of agricultural wastes. Poultry and animal excreta are difficult to burn except under controlled conditions. The open burning of agricultural waste is carried out on the ground, in air curtain incinerators, in pits in the ground, or in open drums or wire mesh containers/baskets. Small-scale (open) burning of waste other than agricultural waste is not discussed in this chapter.

The open burning of agricultural waste is likely to be widespread, although it will rarely be a significant source of emissions except on a local scale for short-time periods. The emissions arising from open burning depend on a number of factors. The most important variables are the type of waste burned and the moisture content of the waste. The ambient temperature and wind conditions, and the density/compactness of the pile of waste also affect the combustion conditions and hence the emissions.

One of the main concerns regarding agricultural waste combustion is the emission of smoke/particulates. Toxic organic micropollutants, such as polycyclic aromatic hydrocarbons (PAHs) and dioxins are likely to be present in the emissions. In many cases, the combustion will be slow and inefficient, and therefore emissions of CO and VOCs will be more significant than emissions of NO_x. The burning of plastics is likely to produce particularly toxic emissions, such as dioxins, other chlorinated organic compounds and cyanides.

Open burning of waste is a source of greenhouse gas emissions, like other types of combustion. Relevant gases emitted include CO₂, methane (CH₄) and nitrous oxide (N₂O). Normally, emissions of CO₂ from waste incineration are more significant than CH₄ and N₂O emissions. Only CO₂ emissions resulting from oxidation, during incineration and open burning of carbon in waste of fossil origin (e.g. plastics, certain textiles, rubber, liquid solvents, and waste oil) are considered net emissions and should be included in the national CO₂ emissions estimate. The CO₂ emissions from combustion of biomass materials (e.g. paper, food, and wood waste) contained in the waste are biogenic emissions and should not be included in national total emission estimates. However, if incineration of waste is used for energy purposes, both fossil and biogenic CO₂ emissions should be estimated. Only fossil CO₂ should be included in national emissions under Energy Sector while biogenic CO₂ should be reported as an information item also in the Energy Sector.

4.8.3.1.2. Factors affecting releases

The application of abatement equipment to open burning is impractical. However, changes in certain agricultural practices can reduce emissions. Waste minimisation and recycling and the use of other more environmentally acceptable disposal methods, such as composting, reduce the quantity of agricultural waste burned. The recycling and reuse of plastics, or the use of disposal methods other than burning, is particularly important. Methods to improve the oxygen supply to agricultural waste during combustion and the burning of dry waste only will improve combustion conditions and reduce emissions.

4.8.3.1.3. Description of release estimation techniques

The CO, NO_x, SO₂, NMVOC, TSP, PM₁₀, PM_{2.5}, BC¹, Cr, Cu, Zn, As, Se, Pb, Cd, benzo(a)pyrene, benzo(b)fluoranthene, benzo(k)fluoranthene, and PCDD/F emissions from open burning are estimated using the following Tier 1 equation:

$$E_{\text{pollutant}} = AR_{\text{production}} \times EF_{\text{pollutant}}$$

where:

$E_{\text{pollutant}}$ = the emission of the specified pollutant

$AR_{\text{production}}$ = the activity rate for other metal production

$EF_{\text{pollutant}}$ = the emission factor for this pollutant

This requires a prior knowledge of the weight of agricultural waste produced per hectare of forestry, orchard and farmland. It is assumed that open burning of agricultural waste (except stubble burning) is mainly practised in forestry, orchard and arable farming; emissions from open burning for other types of farming are likely to be less significant and are assumed to be negligible. It is assumed that the average quantity of agricultural waste disposed of by open burning (except stubble burning) is equivalent to 0.5 % of dry crop residue arising in United Nations Economic Commission for Europe (UNECE) countries.

To use the Tier 1 emission factors, the national area of forestry and orchard is required. If a more detailed methodology is required, then the breakdown of the national area of farmland, forestry and orchard into different types of farming/plantation (including the breakdown of arable farming into areas of different crops) would be needed.

The Tier 1 emission factors assume an averaged or typical technology and abatement implementation in the country. The emission factors, as provided in the 2016 EMEP/EEA Air Pollutant Emission Inventory Guidebook, are: 55.83 kg/Mg waste for CO; 3.18 kg/Mg waste for NO_x; 0.11 kg/Mg waste for SO₂; 1.23 kg/Mg waste for NMVOC; 4.64 kg/Mg waste for TSP; 4.51 kg/Mg waste for PM₁₀; 4.19 kg/Mg waste for PM_{2.5}; 42.0 % of PM_{2.5} for BC¹; 0.01 g/Mg waste for Cr; 0.20 g/Mg waste for Cu; 17.53 g/Mg waste for Zn; 0.41 g/Mg waste for As; 0.07 g/Mg waste for Se; 0.49 g/Mg waste for Pb; 0.10 g/Mg waste for Cd; 2.33 g/Mg waste for benzo(a)pyrene; 4.63 g/Mg waste for benzo(b)fluoranthene; 5.68 g/Mg waste for benzo(k)fluoranthene; and 10 µg I-TEQ/Mg waste for PCDD/F.

The CO₂ emissions from open burning are estimated using the following Tier 1 equation, based on the total amount of waste combusted:

$$\text{CO}_2 \text{ Emissions} = \sum_i (SW_i \times dm_i \times CF_i \times FCF_i \times OF_i) \times 44/12$$

where:

CO₂ Emissions = CO₂ emissions in inventory year, Gg/yr

SW_i = total amount of solid waste of type i (wet weight) incinerated or open-burned, Gg/yr

dm_i = dry matter content in the waste (wet weight) incinerated or open-burned, (fraction)

CF_i = fraction of carbon in the dry matter (total carbon content), (fraction)

FCF_i = fraction of fossil carbon in the total carbon, (fraction)

OF_i = oxidation factor, (fraction)

44/12 = conversion factor from C to CO₂

i = type of waste incinerated/open-burned specified as follows: MSW: municipal solid waste (if not estimated using Equation 5.2), ISW: industrial solid waste, SS: sewage sludge, HW: hazardous waste, CW: clinical waste, others (that must be specified)

Default data on characteristic parameters (such as dry matter content, carbon content and fossil carbon fraction) for different types of waste (MSW, sewage sludge, industrial waste and other waste such as hazardous and clinical waste) are provided in the 2006 IPCC Guidelines for National Greenhouse Gas Inventories. The calculation of the CO₂ emissions is based on an estimate of the amount of waste (wet weight) incinerated or open-burned taking into account the dry matter content, the total carbon content, the fraction of fossil carbon and the oxidation factor. If a country has data on the fraction of fossil carbon in the dry matter, it does not need to provide CF_{*i*} and FCF_{*i*} separately but instead it should combine them into one component.

For MSW, it is good practice to calculate the CO₂ emissions on the basis of waste types/material (such as paper, wood, plastics) in the waste incinerated or open-burned. The CO₂ emissions from open burning of MSW are estimated using the following Tier 1 equation, based on the MSW composition:

$$\text{CO}_2 \text{ Emissions} = \text{MSW} \times \sum_j (\text{WF}_j \times \text{dm}_j \times \text{CF}_j \times \text{FCF}_j \times \text{OF}_j) \times 44/12$$

where:

CO₂ Emissions = CO₂ emissions in inventory year, Gg/yr

MSW = total amount of municipal solid waste as wet weight incinerated or open-burned, Gg/yr

WF_{*j*} = fraction of waste type/material of component *j* in the MSW (as wet weight incinerated or open burned)

dm_{*j*} = dry matter content in the component *j* of the MSW incinerated or open-burned, (fraction) CF_{*j*} = fraction of carbon in the dry matter (i.e. carbon content) of component *j*

FCF_{*j*} = fraction of fossil carbon in the total carbon of component *j*

OF_{*j*} = oxidation factor, (fraction)

44/12 = conversion factor from C to CO₂

j = component of the MSW incinerated/open-burned such as paper/cardboard, textiles, food waste, wood, garden (yard) and park waste, disposable nappies, rubber and leather, plastics, metal, glass, other inert waste.

Activity data needed in the context of open burning of waste includes the amount of waste open-burned, the related waste fractions (composition) and the dry matter content. Ideally, the data used should be representative for the waste incinerated and open-burned. If such data are not available, country-specific data without differentiation by waste type or incineration technology used are still more appropriate than default data.

In most countries, statistics may not be available. Where the data on waste amount are not available, alternative methods such as data from period surveys, research project or expert judgement can be used to estimate total amount of waste burned together with appropriate explanation and documentation. Extrapolation and interpolation can be used to obtain

estimates for years for which no data are available. Population and economic data can be used as drivers.

It is generally more practical to estimate CO₂ emissions from open burning of waste using calculations based on the carbon content in the waste, instead of measuring the CO₂ concentration. More information on this technique can be found in Volume 5, Chapter 5 of the 2006 IPCC Guidelines for National Greenhouse Gas Inventories.

4.8.3.1.4. Spatial allocation

Spatial disaggregation requires knowledge about the location of the farms that will carry out a significant amount of open burning of agricultural waste (other than stubble burning). These are likely to be arable farms as opposed to farms with mainly livestock. Spatial disaggregation might be possible if a Tier 3 methodology is developed as this would estimate emissions from different types of farms.

4.8.3.1.5. Summary of steps in the process

1. Identify activity data for open burning. For estimates of CO₂ emissions, the dry matter content, fraction of carbon in dry matter, fraction of fossil carbon in the total carbon, and an oxidation factor are needed in conjunction with either total solid waste by weight or total MSW by weight.
2. Calculate total emissions by combining activity data, emission factors (adjusted if necessary) and any other data required.
3. Spatially and temporally disaggregate as required

4.8.3.1.6. Comments on reliability

There are little data on emissions from the open burning of agricultural waste (not including stubble burning). However, stubble burning is likely to involve similar combustion conditions to the open burning of agricultural waste, and therefore similar emission factors can be applied. As for many reports on emissions of PAHs and dioxins, significant uncertainty is caused by the fact that ‘total’ PAHs or ‘total’ dioxins in emissions from stubble burning are generally reported, whereas it is likely that only a limited number of compounds were measured. Although information on the area of farmland is likely to be reliable, the estimation of the weight of waste arising per hectare of farmland is very uncertain.

The use of country-specific data may introduce additional uncertainty. If surveys on waste composition are used, the interpretation of definitions of solid waste may differ, leading to varying reliability and accuracy. The major uncertainty associated with CO₂ emissions estimate is related to the estimation of the fossil carbon fraction.

4.8.3.1.7. Sources of further information

Canada

- Environment Canada (2013), Manual for the Compilation of Canada’s 2013 Air Pollutant (Environment Canada, Ottawa, Canada). http://publications.gc.ca/collections/collection_2013/ec/En14-87-2013-eng.pdf.

Europe

- EEA (2016), EMEP/EEA Air Pollutant Emission Inventory Guidebook (European Environment Agency, Copenhagen, Denmark), 2016 Edition. <http://www.eea.europa.eu/publications/emep-eea-guidebook-2016>.

International

- IPCC (2006), 2006 Intergovernmental Panel on Climate Change Guidelines for National Greenhouse Gas Inventories Prepared by the National Greenhouse Gas Inventories Programme, Eggleston H.S., Buendia L., Miwa K., Ngara T. and Tanabe K. (eds). Published: IGES, Japan. <http://www.ipcc-nggip.iges.or.jp/public/2006gl/>.

US

- US EPA (1995-2018), Compilation of Air Pollutant Emission Factors, Volume I, Stationary Point and Area Sources, Chapter 2: Solid Waste Disposal, Section 2.5, Open Burning. AP-42 (United States Environmental Protection Agency, North Carolina, US), 5th Edition. <https://www3.epa.gov/ttn/chief/ap42/ch02/final/c02s05.pdf>.

4.8.4. Wastewater handling

4.8.4.1.1. Nature of the source and relevant pollutants

Wastewater handling includes biological treatment plants and latrines (storage tanks of human excreta, located under naturally ventilated wooden shelters). Biological treatment plants are only of minor importance for emissions into air, and the most important of these emissions are greenhouse gases (CO₂, CH₄ and N₂O). Air pollutants include NMVOC and NH₃; however the contribution to the total emissions is only minor and only of local importance. Latrines are generally only a minor source of emissions (mainly NH₃); however, in Poland, the contribution of this activity to the total ammonia emissions is reported to be about 3 percent.

The main type of wastewater treatment plants in the Netherlands are low-load biological treatment plants with aeration by point aerators.

A latrine is a simple 'dry' toilet built outside the house, usually in a backyard. A storage tank under the latrine can be a hole dug in the ground, or a concrete reservoir. Tanks are emptied by cesspool emptiers or contents are deposited on an animal manure heap. From time to time, chlorinated lime is used for latrine disinfection. Nitrogen content in human excreta depends on the diet, health and physical activity of an individual. Ammonia emissions derive mainly from the decomposition of urea and uric acid. The decomposition of protein in faeces is a slow process, but during storage, 40 to 70 percent of total N is converted to the NH₄⁺ form. Nitrogen is emitted from latrines as NH₃ in a free evaporation process. Ammonia emission from latrines depends on quantity and form of nitrogen compounds in human excreta, as well as on weather conditions.

In general, air emissions of persistent organic pollutants (POPs) as well as NMVOC, CO, and NH₃ occur from wastewater treatment plants, but are mostly insignificant for national total emissions. However, NMVOC emissions from wastewater treatment plants to air may in some cases be significant in urban areas and may even contribute significantly at a national level. Small quantities of NH₃ and NMVOC are emitted as well. Emissions from latrines are mainly NH₃ and also small quantities of CH₄.

4.8.4.1.2. Factors affecting releases

Reduction of ammonia emissions from latrines is possible by the installation of water supply and sewage systems, which is particularly possible in towns.

4.8.4.1.3. Description of release estimation techniques

The NMVOC emissions from wastewater handling are estimated using the following Tier 1 equation:

$$E_{\text{pollutant}} = AR_{\text{production}} \times EF_{\text{pollutant}}$$

where:

$E_{\text{pollutant}}$ = the emission of the specified pollutant

$AR_{\text{production}}$ = the activity rate for wastewater handling

$EF_{\text{pollutant}}$ = the emission factor for this pollutant

The Tier 1 emission factors assume an averaged or typical technology and abatement implementation in the country and integrate all different sub-processes in the handling of wastewater.

The emission factor for NMVOC, as provided in the 2016 EMEP/EEA Air Pollutant Emission Inventory Guidebook, is 15 mg/m³ of wastewater handled. Emission factors for all other pollutants are not available and may be assumed negligible in most cases and therefore, the Guidebook does not include emission factors for these other pollutants.

Consult Volume 5, Chapter 6 of the 2006 IPCC Guidelines for National Greenhouse Gas Inventories for information on emission estimation techniques for CH₄ and N₂O.

4.8.4.1.4. Spatial allocation

For latrines, it is good practice to disaggregate national totals on the basis of population, taking urban and rural differences in the number of latrines into account.

4.8.4.1.5. Summary of steps in the process

1. Identify activity data for wastewater handling.
2. Calculate total emissions by combining activity data, emission factors (adjusted if necessary) and any other data required.
3. Spatially and temporally disaggregate as required.

4.8.4.1.6. Comments on reliability

The emission factor for NMVOC should be handled with care, since it may not be applicable to all wastewater treatment plants.

4.8.4.1.7. Sources of further information

Europe

- EEA (2016), EMEP/EEA Air Pollutant Emission Inventory Guidebook (European Environment Agency, Copenhagen, Denmark), 2016 Edition. <http://www.eea.europa.eu/publications/emep-eea-guidebook-2016>.

International

- IPCC (2006), 2006 Intergovernmental Panel on Climate Change Guidelines for National Greenhouse Gas Inventories Prepared by the National Greenhouse Gas Inventories Programme, Eggleston H.S., Buendia L., Miwa K., Ngara T. and Tanabe K. (eds). Published: IGES, Japan. <http://www.ipcc-nggip.iges.or.jp/public/2006gl/>.

4.8.5. Municipal solid waste

4.8.5.1.1. Nature of the source and relevant pollutants

Emissions from municipal solid waste disposal on land are only a minor source of air pollutant emissions. Treatment and disposal of municipal, industrial, and other solid waste mainly causes greenhouse gas emissions. Fugitive emissions from waste handling at municipal solid waste disposal sites include emissions from the loading of wastes onto storage piles, equipment traffic at the disposal sites, wind erosion of piles and ground areas and possibly the load out of waste, e.g. for waste burning.

Emissions of greenhouse gases including CH₄, CO₂, and N₂O, are the major pollutants. Particulate emissions from waste handling are also generated. Small quantities of NMVOCs, NO_x, NH₃, and CO may be emitted, but there are no estimates available on the emission factors for these pollutants.

Treatment and disposal of municipal, industrial, and other solid waste produces significant amounts of CH₄. CH₄ produced at solid waste disposal sites (SWDS) contributes approximately 3 to 4 percent to the annual global anthropogenic greenhouse gas emissions.

In addition to CH₄, SWDS also produce biogenic CO₂. Decomposition of organic material derived from biomass sources (e.g. crops, wood) is the primary source of CO₂ released from waste. These CO₂ emissions are not included in national totals, because the carbon is of biogenic origin and net emissions are accounted for in other emission inventory sectors.

4.8.5.1.2. Factors affecting releases

In many industrialised countries, waste minimisation and recycling/reuse policies have been introduced to reduce the amount of waste generated, and increasingly, alternative waste management practices to solid waste disposal on land have been implemented to reduce the environmental impacts of waste management. In addition, landfill gas recovery has become more common as a measure to reduce CH₄ emissions from SWDS.

4.8.5.1.3. Description of release estimation techniques

The NMVOC, TSP, PM₁₀, and PM_{2.5} emissions from municipal solid waste are estimated using the following Tier 1 equation:

$$E_{\text{pollutant}} = AR_{\text{production}} \times EF_{\text{pollutant}}$$

where:

$E_{\text{pollutant}}$ = the emission of the specified pollutant

$AR_{\text{production}}$ = the activity rate for municipal solid waste

$EF_{\text{pollutant}}$ = the emission factor for this pollutant

The statistics required include the annual amount of landfilled waste. This information is available from the national statistics agencies, environmental agencies, or may be obtained through direct contact with the landfill site operators.

The Tier 1 emission factors assume an averaged or typical technology and abatement implementation in the country and integrate all different sub-processes in the handling of wastewater. The emission factors, as provided in the 2016 EMEP/EEA Air Pollutant Emission Inventory Guidebook, are: 1.56 kg/Mg for NMVOC; 0.462 g/Mg for TSP; 0.219 g/Mg for PM₁₀; and 0.033 g/Mg for PM_{2.5}.

Consult Volume 5, Chapter 3 of the 2006 IPCC Guidelines for National Greenhouse Gas Inventories for information on emission estimation techniques for CH₄.

4.8.5.1.4. Spatial allocation

National emissions should be disaggregated based on landfill capacity, employment or population statistics.

4.8.5.1.5. Summary of steps in the process

1. Identify activity data for landfills.
2. Calculate total emissions by combining activity data, emission factors (adjusted if necessary) and any other data required.
3. Spatially and temporally disaggregate as required.

4.8.5.1.6. Comments on reliability

The use of country-specific MSW data may introduce uncertainty if surveys on waste composition are used since the interpretation of definitions of solid waste may differ.

4.8.5.1.7. Sources of further information

Europe

- EEA (2016), EMEP/EEA Air Pollutant Emission Inventory Guidebook (European Environment Agency, Copenhagen, Denmark), 2016 Edition. <http://www.eea.europa.eu/publications/emep-eea-guidebook-2016>.

International

- IPCC (2006), 2006 Intergovernmental Panel on Climate Change Guidelines for National Greenhouse Gas Inventories Prepared by the National Greenhouse Gas Inventories Programme, Eggleston H.S., Buendia L., Miwa K., Ngara T. and Tanabe K. (eds). Published: IGES, Japan. <http://www.ipcc-nggip.iges.or.jp/public/2006gl/>.

US

- US EPA (1995-2018), Compilation of Air Pollutant Emission Factors, Volume I, Stationary Point and Area Sources, Chapter 2: Solid Waste Disposal, Section 2.4, Municipal Solid Waste landfills. AP-42 (United States Environmental Protection Agency, North Carolina, US), 5th Edition. <https://www3.epa.gov/ttn/chief/ap42/ch02/draft/d02s04.pdf>.

4.9. Summary of Techniques for Non-point Discharges to Water

4.9.1. Non-point discharges to water

4.9.1.1. Catchment runoff

4.9.1.1.1. Nature of the source and relevant pollutants

Non-point discharges to water result from pollutants contained in catchment runoff entering water bodies. These ‘pollutants’ can be defined as substances that are not released as part of natural processes but result from human activities and land management practices occurring in the catchment. Polluted runoff may pass through various stages before reaching the final receiving waters (*e.g.* it may be collected in pipes then transferred to rivers and finally to inland lakes or the marine environment). Hence, both inland and marine waters may be polluted and merit attention.

The pollutants most commonly estimated from non-point sources are nutrients (total N and P) and sediments (suspended solids). However, the methods described here can be adapted to deal with other contaminants such as metals and organic pollutants.

4.9.1.1.2. Factors affecting releases

Human influences on land use activities can drastically affect nutrient and other pollutant loads. These activities include vegetation removal, urban development and agricultural practices (*e.g.* through the use of fertilisers and pesticides). Nitrogen and phosphorous occur naturally in soils, so a certain amount is washed out naturally as part of the natural nutrient cycle. Human influences lead to additional inputs, often called ‘surpluses’ of N and P, when inputs exceed losses. Nutrient/pollutant generation rates depend on land use and management practices, soil type, topography and climate. These are factors that are likely to vary enormously between different catchment areas and regions or countries.

4.9.1.1.3. Description of release estimation techniques

Much research has focused on the development of modelling techniques to predict water quality impacts from changes in land use and management activities. A wide variety of models and techniques exist to estimate the export of pollutants (*i.e.* pollutant loads) from catchment areas.

Load estimation

There are two main ways of estimating pollutant loads: using real data (*i.e.* from measurements) or modelling. Using real data involves applying various averaging, ratio and regression methods because loads are not measured directly but inferred from measurements of pollutant concentration and water discharge.

Modelling methods are used in the absence of observed data to predict pollutant loads according to relationships between nutrients/pollutants and other environmental attributes, such as population and land use established from other similar catchments. These methods can be used for N, P and other pollutants. Some methods use single predictors such as population density, quantity of fertiliser, or land use. For example, an estimate of nutrient load can be based simply on the area of each land use type within the catchment area and applying a pollutant generation rate. A review of different approaches and testing of their performance in a catchment area in Australia concluded that a multi-factor approach gave the best estimate of nutrient export rates, particularly in situations where no measured data

exist (NSW EPA, 2000_[28]). A multi-factor approach uses a range of input data that are generally available (*e.g.* land use, agricultural practices, soil characteristics). These parameters are used to calculate the non-point pollution load by means of coefficients that are calibrated with data from small homogenous catchment areas. Subtracting the known discharges from the measured transport in the river provides an estimate of the residual pollution load.

There is no single optimal load estimation technique. Selecting one that is appropriate depends on the availability of concentration and discharge data, the desired accuracy of estimates and preferred complexity of the technique. Simple empirical models are not sensitive to climate variability; hence they yield long-term averages only. However, such information is often sufficient for national pollutant inventories and national reporting purposes.

The European Union describes one approach for estimating the load of substances to surface water. Data are derived from the Precipitation Chemistry Database of the Co-operative Programme for the Monitoring and Evaluation of the Long-Range Transmission of Air Pollutants in Europe and based on the EMEP unified model revision 1.7 on a 50 x 50 km grid. Total flux is calculated for each River Basin District Subunit (RBDSU). For each RBDSU, surface water area shares are calculated. Emission fluxes to the surface water per RBDSU are calculated by multiplying the flux per RBDSU by the share of surface water per RBDSU (EC, 2013_[26]).

Catchment modelling

Computer models of sediment/nutrient transport (in which load estimation is a major part) fall into three broad categories:

- **Empirical models:** These are based on simple empirically determined relationships found between observed variables such as climate, land use and fertiliser input. They are the simplest of the three types of models, with a relatively small number of variables, but a high level of spatial and temporal disaggregation.
- **Conceptual models:** These are based on the conceptualisation of the catchment area as a configuration of internal storages and pathways through which pollutants pass. They usually incorporate the underlying physical mechanisms of sediment and runoff generation.
- **Physics-based models:** These are based on fundamental physical equations of flow and transport. They focus on the detailed modelling of processes, including hydrological factors such as rainfall and runoff. They normally require substantial measured input data (both spatial and temporal) and computing power. Physics-based models tend to be used by researchers involved in detailed studies on small spatial scales.

Each class of models has advantages and disadvantages. When selecting a model, the intended use of the model, data and computing resources available will need to be considered. Many models do not belong to one particular category, but have a combination of features from different classes. The categories listed above (adopted in the NSW EPA report referenced below) are not universally agreed by modelling professionals.

It is not necessarily the case that model accuracy increases with model complexity. Complex models suffer from problems such as error accumulation and unrealistic assumptions about the basic physics in the catchment system. In addition, a lack of input data means that model parameters have to be determined through calibration. This leads to

the problem of non-uniqueness and, therefore, the ultimate reliability of the predictions is questionable.

A common approach is to use empirical models (sometimes referred to as decision-support systems) to assist land use and land management planning. They do not give definitive solutions to problems but are a useful tool for identifying sources of pollutants, assessing management practices within a catchment area, and allowing relative assessments for different loads and catchments at an indicative level. Although not highly accurate, they are particularly useful when no measured data are available and only key nutrient sources and processes need to be characterised.

At the catchment scale, complex physics-based models are often not appropriate, nor can they be used in the absence of extensive input data.

4.9.1.1.4. Comments on reliability

There are often large differences between measured and estimated loads computed using different methods. The reasons may include factors such as the lack of consideration of topography and soil erosion, climatic factors and the inaccurate interpretation/categorisation of land use classes. When data are poor or non-existent, it is preferable not to rely on a single estimation technique. If a catchment suffers from lack of data, it will be very difficult to prove that any particular method produces acceptable results. In such cases, all the assumptions and the uncertainty limits of the outcomes should be clearly specified.

4.9.1.1.5. Sources of further information

Preparation of non-point inventories on discharges to water is an inherent part of the catchment modelling process, and is also a complex area of scientific endeavour. A significant amount of this work occurs within research organisations, which often may not be directly connected with government activities. Preparing a non-point inventory on discharges to water also requires a greater depth of expert knowledge than in the non-point air emissions inventory area, so inexperienced people attempting to apply the techniques would first need to identify research groups in their own country who can provide expert advice. More complex approaches will normally need to be applied by expert researchers. Unlike the air emissions inventory area, there are no extensive guidance documents on inventories on discharges to water provided by national governments and international agencies for countries to use.

Australia

- NSW EPA (1999), *Review of Techniques to Estimate Catchment Exports* (New South Wales EPA, Sydney, NSW, Australia). <http://www.npi.gov.au/system/files/resources/ac997f84-17a2-f724-6def-bd3a47b9e4b4/files/nswreport.pdf>.
- NSW EPA (2000), *Comparison of Selected Models to Estimate Nutrient Loadings*. Report prepared by Sinclair Knight Merz and the Integrated Assessment & Management Centre, ANU (New South Wales EPA, Sydney, NSW, Australia).

Europe

- EEA (1998), *A European Inventory of Emissions to Inland Waters*. Technical Report No. 8 (EEA, Copenhagen, Denmark).

- EC (2013), Diffuse water emissions in E-PRTR, (European Commission, European Union, Luxembourg), [http://fis.freshwatertools.eu/files/MARS_resources/Info_lib/Deltares\(2013\)Diffuse%20water%20emissions%20in%20E-PRTR%202013%20project%20report.pdf](http://fis.freshwatertools.eu/files/MARS_resources/Info_lib/Deltares(2013)Diffuse%20water%20emissions%20in%20E-PRTR%202013%20project%20report.pdf).

US

- US EPA: Basins 4.1 Model. <https://www.epa.gov/ceam/better-assessment-science-integrating-point-and-non-point-sources-basins>.

5. CONCLUSIONS

The Resource Compendium provides information about RETs used to quantify releases from non-point sources. In addition, it gives an overview of inventories that include releases from non-point sources across OECD countries and it summarises methods for estimating releases from selected sources. Through the collection and collation of information for this document, it was found that while inventories incorporating non-point sources are widespread for air and water, these inventories are rarely integrated across all environmental media, or with national PRTRs. Decision makers, as they look to extend their PRTRs to include non-point sources, may wish to (1) build on existing national and international inventory activities and (2) develop links and share information and knowledge.

5.1. Build on existing inventory activities

As described in Annex C, there is an extensive history of work in relation to inventories covering an entire country as well as for specific airsheds and water catchments. These have mostly been developed to serve government planning and policy-making purposes, as well as for international reporting requirements.

Public access to these data varies significantly, and often data are not disseminated to the public. For instance, air inventories and inventories on discharges to water are normally prepared by quite separate arms of government, with inventories on discharges to water often being created by research groups outside governments.

PRTR programmes need to build on the work already done rather than set up separate programmes for non-point emissions estimation. Some countries have taken steps towards collecting information and providing diffuse source emissions for access by public²⁶. There is scope to integrate existing inventories and add value to PRTRs by including existing data on non-point emissions. A starting point for PRTR developers would be to:

- identify existing inventories;
- review these existing inventories to understand their scope and objectives, what data are collected, what sources are covered, spatial and temporal resolution, data reliability etc.; and
- consider how these existing inventories can be linked with the proposed (or existing) PRTR (*e.g.* common data sources, overlaps).

The methodologies and approaches described in Chapter 4 should enable PRTR developers to commence this process and ensure that the benefits of existing inventory programmes are obtained when incorporating non-point sources into PRTRs.

5.2. Develop links and share knowledge

There is scope for OECD to develop links with key actors involved in non-point source inventories, involving international bodies and individual countries. Building links could be carried out on two levels:

- encouraging the integration of inventories at the user interface; and

²⁶ See <https://prtr.eea.europa.eu/#/diffemissionsair> and <https://prtr.eea.europa.eu/#/diffemissionswater>.

- facilitating the sharing of data among inventory practitioners.

6. RELEVANT SOURCES OF INFORMATION

6.1. Air Emissions Inventory Guidance and Emission Factors

- CARB (1991a), Identification of Volatile Organic Compound Species Profiles, ARB Speciation Manual, Volume 1 (California Air Resources Board, California, US), 2nd edition. <https://www.ourair.org/wp-content/uploads/CARB-VOC-Species-Profiles.pdf>
- CARB (1991b), Identification of Particulate Matter Species Profiles, ARB Speciation Manual, Volume 2 (California Air Resources Board, California, US), 2nd edition.
- CARB (2014), Area-Wide Source Methodologies (California Air Resources Board, California, US). <https://ww3.arb.ca.gov/ei/areasrc/areameth.htm>
- CARB (2018), Speciation Profiles Used in ARB Modeling (California Air Resources Board, California, US). <https://ww3.arb.ca.gov/ei/speciate/speciate.htm>
- Djurhuus, Håkun, Hemmer, Per, Vilsbøll, Anne Sophie K, Brandt, Jacob. (2013). Environmental law and practice in Denmark: overview. (Bech-Bruun, Denmark). [https://uk.practicallaw.thomsonreuters.com/0-522-0619?_lrTS=20170510075610490&transitionType=Default&contextData=\(sc.Default\)&firstPage=true&bhcp=1](https://uk.practicallaw.thomsonreuters.com/0-522-0619?_lrTS=20170510075610490&transitionType=Default&contextData=(sc.Default)&firstPage=true&bhcp=1)
- Environment Australia (1999), Emissions Estimation Technique Manual for Aggregated Emissions from Bush Fires and Prescribed Burning (Environment Australia, Canberra, Australia). <http://www.npi.gov.au/system/files/resources/cf3d7ecb-b57f-70d4-e976-03cb241c888e/files/burningff.pdf>.
- Environment Australia (1999), Emissions Estimation Technique Manual for Aggregated Emissions from Domestic Solid Fuel Burning (Environment Australia, Canberra, Australia). <http://www.npi.gov.au/system/files/resources/0af0be7a-d872-cd34-858f-f35a1119a85d/files/solidfuelrev2.pdf>.
- Environment Australia (1999), Emissions Estimation Technique Manual for Aggregated Emissions from Domestic Gaseous Fuel Burning (Environment Australia, Canberra, Australia). <http://www.npi.gov.au/system/files/resources/a9a62e48-af10-b004-9502-628d44e01ba0/files/gasburningff.pdf>.
- Environment Australia (1999), Emissions Estimation Technique Manual for Aggregated Emissions from Domestic Lawn Mowing (Environment Australia, Canberra, Australia). <http://www.npi.gov.au/system/files/resources/775a55ca-2c34-6434-11cc-13d988e40ec7/files/lawnmowingrev2.pdf>.
- Environment Australia (1999), Emissions Estimation Technique Manual for Aggregated Emissions from Barbecues (Environment Australia, Canberra, Australia). <http://www.npi.gov.au/system/files/resources/9f4e8732-3e1d-4134-d592-34f412d69d31/files/barbeques.pdf>.
- Environment Australia (1999), Emissions Estimation Technique Manual for Aggregated Emissions from Cutback Bitumen (Environment Australia, Canberra, Australia). <http://www.npi.gov.au/system/files/resources/d5254734-18b0-fe44-b166-0d60e0583567/files/bitumenrev2.pdf>.
- Environment Australia (1999), Emissions Estimation Technique Manual for Aggregated Emissions from Dry Cleaning (Environment Australia, Canberra, Australia). <http://www.npi.gov.au/system/files/resources/4988e0f4-c0aa-8304-f5f6-d5aaea773d93/files/drycleanrev.pdf>.
- Environment Australia (1999), Emissions Estimation Technique Manual for Aggregated Emissions from Motor Vehicle Refinishing (Environment Australia, Canberra, Australia). <http://www.npi.gov.au/system/files/resources/eba010ab-11cf-8164-6112-6a6fd1851ccf/files/mvrefinishrev2.pdf>.
- Environment Australia (1999), Emissions Estimation Technique Manual for Aggregated Emissions from Printing and Graphic Arts (Environment Australia, Canberra, Australia). <http://www.npi.gov.au/system/files/resources/d3243415-affc-d154-39b9-e4ddd10019f1/files/printingrev.pdf>.
- Environment Australia (1999), Emissions Estimation Technique Manual for Aggregated Emissions from Service Stations (Environment Australia, Canberra, Australia).

- <http://www.npi.gov.au/system/files/resources/5310d8c0-7667-0004-71f1-03e044e70993/files/servstatnsrev4.pdf>.
- Environment Australia (1999), Emissions Estimation Technique Manual for Aggregated Emissions from Use of Industrial Solvents (Sub-threshold) (Environment Australia, Canberra, Australia). <http://www.npi.gov.au/system/files/resources/32c5dd6e-bc9f-c4a4-757f-7231d4cbd838/files/subsolventrev2.pdf>.
- Environment Australia (1999), Emissions Estimation Technique Manual for Aggregated Emissions from Fuel Combustion (Sub-threshold) (Environment Australia, Canberra, Australia). <http://www.npi.gov.au/system/files/resources/e097577e-4439-6fb4-fd8f-2bcfaf9c8077/files/subcombustionff.pdf>.
- Environment Australia (1999), Emissions Estimation Technique Manual for Aggregated Emissions from Commercial Ships/Boats and Recreational Boats (Environment Australia, Canberra, Australia). <http://www.npi.gov.au/system/files/resources/8a6079c5-fae1-0fd4-31b7-69a026bd0a17/files/shipping.pdf>.
- Environment Australia (1999), Emissions Estimation Technique Manual for Aggregated Emissions from Domestic/Commercial Solvent and Aerosol Use (Environment Australia, Canberra, Australia). <http://www.npi.gov.au/system/files/resources/50d07831-eda6-e564-91d5-bfde6a529fa0/files/domcomsolventsrev.pdf>.
- Environment Australia (1999), Emissions Estimation Technique Manual for Aggregated Emissions from Paved and Unpaved Roads (Environment Australia, Canberra, Australia). <http://www.npi.gov.au/system/files/resources/fdfa6fd9-50dc-acb4-c9fb-e01155914210/files/pavedunpavedff.pdf>.
- Environment Australia (1999), Emissions Estimation Technique Manual for Aggregated Emissions from Railways (Environment Australia, Canberra, Australia). <http://www.npi.gov.au/system/files/resources/10bae364-58df-b8a4-35a8-7e926641cc01/files/railwayrev2.pdf>.
- Environment Australia (2000), Emissions Estimation Technique Manual for Aggregated Emissions from Motor Vehicles (Environment Australia, Canberra, Australia). <http://www.npi.gov.au/system/files/resources/b77f7707-7616-dad4-c93d-fb0330025c3b/files/motorvehicles.pdf>.
- Environment Australia (2003), Emissions Estimation Technique Manual for Aggregated Emissions from Aircraft (Environment Australia, Canberra, Australia). <http://www.npi.gov.au/system/files/resources/7c29f57e-fb3e-a0d4-e5f3-8e3b559d0f75/files/aircraft.pdf>.
- Environment Australia (2003), Emissions Estimation Technique Manual for Aggregated Emissions from Architectural Surface Coatings (Environment Australia, Canberra, Australia). <http://www.npi.gov.au/system/files/resources/253a136a-c9cd-4c54-d9c4-f3e3fe70a42b/files/archcoat.pdf>.
- Environment Australia (2014), Australian Motor Vehicle Emission Inventory for the National Pollutant Inventory (NPI) (Department of the Environment, St. Lucia, Australia). http://www.npi.gov.au/system/files/resources/e8311456-8a41-4473-9fa1-d2f9994ff8da/files/australian-motor-vehicle-emissions-inventory-2014_0.pdf
- Environment Canada (2013), Manual for the Compilation of Canada's 2013 Air Pollutant Emissions (Environment Canada, Ottawa, Canada). http://publications.gc.ca/collections/collection_2013/ec/En14-87-2013-eng.pdf.
- EEA (2016), EMEP/EEA Air Pollutant Emission Inventory Guidebook (European Environment Agency, Copenhagen, Denmark), 2016 Edition. <http://www.eea.europa.eu/publications/emep-eea-guidebook-2016>.
- EC (2016), JRC Technical Report. Soil threats in Europe: status, methods, drivers and effects on ecosystem services, (European Commission, European Union, Luxembourg), http://esdac.jrc.ec.europa.eu/public_path/shared_folder/doc_pub/EUR27607.pdf
- ICAO (2019), *ICAO Aircraft Engine Emissions Data Bank*, International Civil Aviation Organisation, Committee on Aviation Environmental Protection, Montreal, Canada. <http://easa.europa.eu/document-library/icao-aircraft-engine-emissions-databank>.
- IPCC (2006), 2006 Intergovernmental Panel on Climate Change Guidelines for National Greenhouse Gas Inventories Prepared by the National Greenhouse Gas Inventories Programme, Eggleston H.S., Buendia L., Miwa K., Ngara T. and Tanabe K. (eds). Published: IGES, Japan. <http://www.ipcc-nggip.iges.or.jp/public/2006gl/>.

- IPCC (2000), IPCC Report on Good Practice Guidance and Uncertainty Management in National Greenhouse Gas Inventories (IPCC Technical Support Unit, Kanagawa, Japan). http://agrienvarchive.ca/bioenergy/download/ipcc_ghg_inv.pdf.
- IPCC (2019), 2019 Refinement to the 2006 IPCC Guidelines for National Greenhouse Gas Inventories. <https://www.ipcc-nggip.iges.or.jp/public/2019rf/index.html>
- Lloyd's Register (1995), Marine Exhaust Emissions Research Programme (Lloyd's Register, Croydon, UK).
- Ministerie van Volkshuisvesting, Ruimtelijke Ordening en Milieubeheer (1995), Emissies van Stortplaatsen, Report No. 28 (Ministerie van Volkshuisvesting, Ruimtelijke Ordening en Milieubeheer, Den Haag, The Netherlands), <http://publications.tno.nl/publication/34620881/ori9ax/coops-1995-emissies.pdf>.
- Ministerie van Volkshuisvesting, Ruimtelijke Ordening en Milieubeheer (1998), Methoden voor de Bepaling van Emissies naar lucht en Water, Report No. 44 (Ministerie van Volkshuisvesting, Ruimtelijke Ordening en Milieubeheer Den Haag, The Netherlands).
- Ministerie van Volkshuisvesting, Ruimtelijke Ordening en Milieubeheer (1999), Emissies naar de Lucht van Consumenten en Kleine Bedrijven, Report No. 49 (Ministerie van Volkshuisvesting, Ruimtelijke Ordening en Milieubeheer Den Haag, The Netherlands).
- Ministerie van Volkshuisvesting, Ruimtelijke Ordening en Milieubeheer (1999), Methoden voor de bepaling van de Emissies van Kleine Bedrijven, Report No. 50 (Ministerie van Volkshuisvesting, Ruimtelijke Ordening en Milieubeheer Den Haag, The Netherlands).
- National Institute for Public Health and the Environment (RIVM). (2016). Greenhouse Gas Emissions in the Netherlands: 1990-2014, National Inventory Report 2016. (National Institute for Public Health and the Environment Ministry of Health, Welfare, and Sport, The Netherlands). <https://www.pbl.nl/sites/default/files/cms/publicaties/pbl-2016-greenhouse-gas-emissions-in-the-netherlands-1990-2014-niv2016-2413.pdf>
- National Institute for Public Health and the Environment (RIVM). (2018). Greenhouse Gas Emissions in the Netherlands: 1990-2016, National Inventory Report 2018. (National Institute for Public Health and the Environment Ministry of Health, Welfare, and Sport, The Netherlands). https://www.pbl.nl/sites/default/files/cms/publicaties/PBL2018_Greenhouse-gas-emissions-in-the-Netherlands-1990-2016_3262.pdf
- NGGIC (1996), Australian Methodology for the Estimation of Greenhouse Gas Emissions and Sinks Workbook 2.1, Revision 1 (Department of the Environment, Sport and Territories, Canberra, Australia), <https://catalogue.nla.gov.au/Record/1135772>.
- United Kingdom (2019), National Atmospheric Emissions Inventory, Emission Factors, UK, <http://naei.beis.gov.uk/data/emission-factors>
- US EIA (2017), State Energy Data 2017 Consumption Appendix E. Metric and Other Physical Conversion Factors (Energy Information Administration, Washington, D.C., US). https://www.eia.gov/state/seds/sep_use/notes/use_e.pdf.
- US EPA (1985), Compilation of Air Pollutant Emission Factors, Volume II, Mobile Sources, AP-42 (United States Environmental Protection Agency, North Carolina, US), 5th edition. This volume is no longer maintained. More current mobile source emission factors are available using the Office of Transportation and Air Quality (OTAQ) mobile source models (<http://www.epa.gov/otaq/models.htm>).
- US EPA (1992), Procedures for Emission Inventory Preparation, Volume IV: Mobile Sources (Office of Mobile Sources, United States Environmental Protection Agency, Washington, D.C., US). <https://nepis.epa.gov/Exe/ZyPDF.cgi/P1009ZEK.PDF?Dockey=P1009ZEK.PDF>.
- US EPA (1994), PM-10 Emissions Inventory Requirements (United States Environmental Protection Agency, North Carolina, US). <https://nepis.epa.gov/Exe/ZyPDF.cgi/000034YN.PDF?Dockey=000034YN.PDF>.
- US EPA (1995-2018), Compilation of Air Pollutant Emission Factors, Volume I, Stationary Point and Area Sources, AP-42 (United States Environmental Protection Agency, North Carolina, US), 5th edition. <https://www.epa.gov/air-emissions-factors-and-quantification/ap-42-compilation-air-emissions-factors>.
- US EPA (1997), Introduction to the Emission Inventory Improvement Programme, Volume I of EIIP Document Series, prepared by Eastern Research Group, North Carolina, US (United States Environmental Protection Agency, North Carolina, US). <https://www.epa.gov/sites/production/files/2015-08/documents/i01.pdf>.
- US EPA (1995-2001), Area Sources, Volume III of EIIP Document Series, prepared by various authors, (United States Environmental Protection Agency, North Carolina, US). <https://www.epa.gov/air-emissions-inventories/volume-3-area-sources-and-area-source-method-abstracts>.

- US EPA (1996-98), Mobile Sources, Volume IV of EIIIP Document Series, prepared by various authors, (United States Environmental Protection Agency, North Carolina, US). <https://www.epa.gov/air-emissions-inventories/volume-4-mobile-sources>.
- US EPA (1996), Biogenic Sources, Volume V of EIIIP Document Series, prepared by Radian Corporation, Research Triangle Park, North Carolina, US (United States Environmental Protection Agency, North Carolina, US). <https://www.epa.gov/sites/production/files/2015-08/documents/v01.pdf>.
- US EPA (1996-97), Quality Assurance Procedures, Volume VI of EIIIP Document Series, prepared by various authors, (United States Environmental Protection Agency, North Carolina, US). <https://www.epa.gov/air-emissions-inventories/volume-6-quality-assurance-procedures-and-dars-software>.
- US EPA (2019), *Inventary of U.S. Greenhouse Gas Emissions and Sinks 1990-2017*, Chapter 3. Energy, EPA 430-R-19-001, <https://www.epa.gov/sites/production/files/2019-04/documents/us-ghg-inventory-2019-main-text.pdf>.
- US EPA (1999), Particulate Emissions, Volume IX of EIIIP Document Series, prepared by Pacific Environmental Services, US (United States Environmental Protection Agency, North Carolina, US). <https://www.epa.gov/air-emissions-inventories/volume-9-particulate-emissions>.
- US EPA (1996), Procedures for Verification of Emissions Inventories (United States Environmental Protection Agency, North Carolina, US), <https://nepis.epa.gov/Exe/ZyNET.exe/2000DWCG.TXT?ZyActionD=ZyDocument&Client=EPA&Index=1995+Thru+1999&Docs=&Query=&Time=&EndTime=&SearchMethod=1&TocRestrict=n&Toc=&TocEntry=&QField=&QFieldYear=&QFieldMonth=&QFieldDay=&IntQFieldOp=0&ExtQFieldOp=0&XmlQuery=&File=D%3A%5Czyfiles%5CIndex%20Data%5C95thru99%5CTxt%5C00000006%5C2000DWCG.txt&User=ANONYMOUS&Password=anonymous&SortMethod=h%7C-&MaximumDocuments=1&FuzzyDegree=0&ImageQuality=r75g8/r75g8/x150y150g16/i425&Display=hpfr&DefSeekPage=x&SearchBack=ZyActionL&Back=ZyActionS&BackDesc=Results%20page&MaximumPages=1&ZyEntry=1&SeekPage=x&ZyPURL>.
- US EPA (1998), Handbook for Air Toxics Emissions Inventory Development Volume I: Stationary Sources, (United States Environmental Protection Agency, North Carolina, US), <https://nepis.epa.gov/Exe/ZyNET.exe/P1006KPL.TXT?ZyActionD=ZyDocument&Client=EPA&Index=1995+Thru+1999&Docs=&Query=&Time=&EndTime=&SearchMethod=1&TocRestrict=n&Toc=&TocEntry=&QField=&QFieldYear=&QFieldMonth=&QFieldDay=&IntQFieldOp=0&ExtQFieldOp=0&XmlQuery=&File=D%3A%5Czyfiles%5CIndex%20Data%5C95thru99%5CTxt%5C00000025%5CP1006KPL.txt&User=ANONYMOUS&Password=anonymous&SortMethod=h%7C-&MaximumDocuments=1&FuzzyDegree=0&ImageQuality=r75g8/r75g8/x150y150g16/i425&Display=hpfr&DefSeekPage=x&SearchBack=ZyActionL&Back=ZyActionS&BackDesc=Results%20page&MaximumPages=1&ZyEntry=1&SeekPage=x&ZyPURL>.
- US EPA (1999), Handbook for Criteria Pollutant Inventory Development: A Beginner's Guide for Point and Area Sources (United States Environmental Protection Agency, North Carolina, US), <https://nepis.epa.gov/Exe/ZyNET.exe/P1000MVP.TXT?ZyActionD=ZyDocument&Client=EPA&Index=1995+Thru+1999&Docs=&Query=&Time=&EndTime=&SearchMethod=1&TocRestrict=n&Toc=&TocEntry=&QField=&QFieldYear=&QFieldMonth=&QFieldDay=&IntQFieldOp=0&ExtQFieldOp=0&XmlQuery=&File=D%3A%5Czyfiles%5CIndex%20Data%5C95thru99%5CTxt%5C00000020%5CP1000MVP.txt&User=ANONYMOUS&Password=anonymous&SortMethod=h%7C-&MaximumDocuments=1&FuzzyDegree=0&ImageQuality=r75g8/r75g8/x150y150g16/i425&Display=hpfr&DefSeekPage=x&SearchBack=ZyActionL&Back=ZyActionS&BackDesc=Results%20page&MaximumPages=1&ZyEntry=1&SeekPage=x&ZyPURL>.

6.2. Air Emissions Inventory Reports

- AEA Technology (1999), National Atmospheric Emissions Inventory: UK Emissions of Air Pollutants 1970 to 1997 (AEA Technology, National Environmental Technology Centre, England). <https://uk-air.defra.gov.uk/assets/documents/reports/empire/naei/annreport/naei97.html>.
- Brown, P (2019), UK Greenhouse Gas Inventory, 1990 to 2017: Annual Report for Submission under the Framework Convention on Climate Change, ISBN 978-0-9933975-5-4, https://uk-air.defra.gov.uk/assets/documents/reports/cat07/1905151122_ukghgi-90-17_Main_Issue_2_final.pdf

- Department for Environment, Food & Rural Affairs (2016), Emissions of Air Quality Pollutants 1990-2014. https://uk-air.defra.gov.uk/assets/documents/reports/cat07/1609130906_NAEI_AQPI_Summary_Report_1990-2014_Issue1.1.pdf
- CITEPA (2016), Emissions Inventories (CITEPA, Paris, France). <https://www.citepa.org/en/activities/emission-inventories>.
- EEA (1999), Air Emissions: Annual Topic Update 1998, Topic Report No. 12 (EEA, Copenhagen Denmark).
- EEA (2001), Air Emissions: Annual Topic Update 2000, Topic Report No. 5 (EEA, Copenhagen Denmark), https://www.eea.europa.eu/publications/Topic_report_No_052001/.
- Environment and Climate Change Canada (2018), 1990-2016 Air Pollutant Emission Inventory Report. (Environment and Climate Change Canada, Quebec, Canada). <https://www.canada.ca/content/dam/eccc/images/apei/apei-2018-en.pdf>.
- EPAV (1991), Air Emissions Inventory Port Phillip Control Region: Planning for the Future. SRS 91/001 (EPA, Victoria, Australia).
- EPAV (1996), National Pollutant Inventory: Technical Report on the Air Emissions Trials for the NPI, Volume 2 (AGPS, Commonwealth of Australia, Canberra, Australia).
- EPAV (1998), Port Phillip Air Emissions Inventory (EPA, Victoria, Australia). http://www.epa.vic.gov.au/air/emissions_inventory/default.asp.
- EPAV (1999), Measurements of Motor Vehicle Pollutants and Fleet Average Emission Factors in Melbourne. Publication No. 652 (EPA, Victoria, Australia).
- London Research Centre (2019), London Atmospheric Emissions Inventory (LAEI) 2016 (London Research Centre, London, UK). <https://data.london.gov.uk/dataset/london-atmospheric-emissions-inventory--laei--2016>
- Ministry of Housing, Spatial Planning and the Environment (2000), Emission Data for The Netherlands 1997 and Estimates for 1998 (Ministry of Housing, Spatial Planning and the Environment, Den Haag, The Netherlands).
- NERI (1999). The Danish CORINAIR Inventories (Ministry of Environment and Energy, National Environmental Research Institute, Roskilde, Denmark), https://www.dmu.dk/1_viden/2_publicationer/3_fagrappporter/rapporter/fr287.pdf.
- NERI (2000), Benzene from Traffic (Ministry of Environment and Energy, National Environmental Research Institute, Roskilde, Denmark), https://www.dmu.dk/1_viden/2_publicationer/3_fagrappporter/rapporter/fr309.pdf.
- Statistics Norway (2000), The Norwegian Emissions Inventory (Statistics Norway, Oslo, Norway).
- Statistics Norway (2016), The Norwegian Emission Inventory 2016 (Statistics Norway, Oslo, Norway). <https://www.ssb.no/natur-og-miljo/artikler-og-publikasjoner/the-norwegian-emission-inventory-2016>
- US EPA (2018), 2014 National Emissions Inventory, Version 2, Technical Support Document, (United States Environmental Protection Agency, North Carolina, US), https://www.epa.gov/sites/production/files/2018-07/documents/nei2014v2_tsd_05jul2018.pdf
- US EPA (2019a), Our Nation's Air (United States Environmental Protection Agency, North Carolina, US). <https://gispub.epa.gov/air/trendsreport/2019/#home>.
- US EPA (2019b), Inventory of U.S. Greenhouse Gas Emissions and Sinks 1990-2017, EPA 430-R-19-001, <https://www.epa.gov/sites/production/files/2019-04/documents/us-ghg-inventory-2019-main-text.pdf>
- VMM (2016), Lozingen in de Lucht 2000-2015 (Flemish Environment Agency, Brussels, Belgium), <https://www.vmm.be/publicaties/lozingen-in-de-lucht-2000-2015>.

6.3. Non-point Inventories on Discharges to Water

- EEA (1998), A European Inventory of Emissions to Inland Waters. Technical Report No. 8 (EEA, Copenhagen, Denmark), <https://www.eea.europa.eu/publications/TEC08/>.
- Environment Canada (1998), 1997 Annual Report on the Federal-Provincial Agreements for the Eastern Canada Acid Rain Programme (EC, Ottawa, Canada), http://publications.gc.ca/collections/collection_2019/eccc/En40-11-29-1997-eng.pdf.
- Environment Australia (2000), Emission Estimation Technique Manual for The Aquaculture of Barramundi, Prawns, Crocodiles, Pearl oysters, Red claw and Tropical abalone In Tropical Australia (Environment Australia, Canberra, Australia). <http://www.npi.gov.au/system/files/resources/70e0763a-7f21-0674-3d2d-d2b1c7d441ad/files/aquatropic.pdf>.

- Environment Australia (2001), Emissions Estimation Technique Manual for Aquaculture from Temperate Water Finfish Aquaculture (Environment Australia, Canberra, Australia). <http://www.npi.gov.au/system/files/resources/e2fdd93d-2693-7df4-89fb-5b5a849b730d/files/aquatemp.pdf>
- NSW EPA (1999), Review of Techniques to Estimate Catchment Exports (New South Wales EPA, Sydney, Australia). <http://www.npi.gov.au/system/files/resources/ac997f84-17a2-f724-6def-bd3a47b9e4b4/files/nswreport.pdf>.
- Preston, Stephen D., Richard B. Alexander, Gregory E. Schwarz, and Charles G. Crawford, 2011. Factors Affecting Stream Nutrient Loads: A Synthesis of Regional SPARROW Model Results for the Continental United States. Journal of the American Water Resources Association (JAWRA) 47(5):891-915. DOI: 10.1111/j.1752-1688.2011.00577.x, <https://www.ncbi.nlm.nih.gov/pmc/articles/PMC3307615/pdf/jawr0047-0891.pdf>

6.4. PRTR Reports

- Environment Canada (1998), National Pollutant Release Inventory – National Overview (EC, Ottawa, Canada).
- Environment Canada (2018), National Pollutant Release Inventory – About the NPRI (EC, Ottawa, Canada), <https://www.canada.ca/en/environment-climate-change/services/national-pollutant-release-inventory/about-national-pollutant-release-inventory.html>.
- EC (2006), Guidance Document for the Implementation of the European PRTR, (European Commission, European Union, Luxembourg) <https://prtr.eea.europa.eu/#/downloadguidance>.
- EC (2019), European Pollutant Release and Transfer Register (E-PRTR), (European Commission, European Union, Luxembourg), <https://www.eea.europa.eu/data-and-maps/data/member-states-reporting-art-7-under-the-european-pollutant-release-and-transfer-register-e-prtr-regulation-18> and <https://ec.europa.eu/environment/industry/stationary/eper/implementation.htm>.
- OECD (1996), Pollutant Release and Transfer Registers (PRTRs): Guidance Manual for Governments (OECD, Paris, France).
- OECD (1999), Proceedings of the OECD International Conference on Pollutant Release and Transfer Registers (PRTRs): National and Global Responsibility, Tokyo – September 1998, PRTR Series No. 1-2 (OECD, Paris, France).
- OECD (2000a), Summary of the Workshop on PRTR Release Estimation Techniques, Canberra, Australia. 15-17 December 1999 (OECD, Paris, France).
- OECD (2000b), Implementing PRTRs: Status of Member Country Activities (OECD, Paris, France).
- OECD (2000c), Presentation and Dissemination of PRTR Data: Practices and Experiences, Getting the Word and Numbers Out, PRTR Series No 3 (OECD, Paris, France).
- OECD (2001), How Pollutant Release and Transfer Registers Differ: A Review of National Programmes, PRTR Series No. 4 (OECD, Paris, France)
- OECD (2002 rev. 2013), Resource Compendium of PRTR Release Estimation Techniques, Part 1: Summary of Point Source Techniques, PRTR Series No. 5 (OECD, Paris, France), [http://www.oecd.org/officialdocuments/publicdisplaydocumentpdf/?cote=env/jm/mono\(2002\)20/rev1&doclanguage=en](http://www.oecd.org/officialdocuments/publicdisplaydocumentpdf/?cote=env/jm/mono(2002)20/rev1&doclanguage=en)
- OECD (2005), Framework for Selecting and Applying PRTR Release Estimation Techniques, ENV/JM/MONO(2005)18, [http://www.oecd.org/officialdocuments/publicdisplaydocumentpdf/?cote=env/jm/mono\(2005\)18&doclanguage=en](http://www.oecd.org/officialdocuments/publicdisplaydocumentpdf/?cote=env/jm/mono(2005)18&doclanguage=en)
- OECD (2008a), Considerations for Ensuring Quality PRTR Data, ENV/JM/MONO(2008)11, [http://www.oecd.org/officialdocuments/publicdisplaydocumentpdf/?cote=env/jm/mono\(2008\)11&doclanguage=en](http://www.oecd.org/officialdocuments/publicdisplaydocumentpdf/?cote=env/jm/mono(2008)11&doclanguage=en)
- OECD (2008b), Scoping Study on the Inclusion of Releases and Transfers from Small and Medium-sized Enterprises (SMEs) in PRTRs, ENV/JM/MONO(2008)5, [http://www.oecd.org/officialdocuments/publicdisplaydocumentpdf/?cote=env/jm/mono\(2008\)5&doclanguage=en](http://www.oecd.org/officialdocuments/publicdisplaydocumentpdf/?cote=env/jm/mono(2008)5&doclanguage=en)
- OECD (2010 rev. 2011, 2015 and 2017) Resource Compendium of PRTR Release Estimation Techniques, Part IV Summary of Techniques for Releases from Products, Volumes 1 and 2, [http://www.oecd.org/officialdocuments/publicdisplaydocumentpdf/?cote=env/jm/mono\(2017\)2/ann&doclanguage=en](http://www.oecd.org/officialdocuments/publicdisplaydocumentpdf/?cote=env/jm/mono(2017)2/ann&doclanguage=en)

- OECD (2013), Global Pollutant Release and Transfer Register, Proposal for a Harmonised List of Reporting Sectors, ENV/JM/MONO(2013)5, [http://www.oecd.org/officialdocuments/publicdisplaydocumentpdf/?cote=env/jm/mono\(2013\)5&doclanguage=en](http://www.oecd.org/officialdocuments/publicdisplaydocumentpdf/?cote=env/jm/mono(2013)5&doclanguage=en)
- OECD (2014a), Guidance Document on Elements of a PRTR: Part I, ENV/JM/MONO(2014)33, [http://www.oecd.org/officialdocuments/publicdisplaydocumentpdf/?cote=env/jm/mono\(2014\)33&doclanguage=en](http://www.oecd.org/officialdocuments/publicdisplaydocumentpdf/?cote=env/jm/mono(2014)33&doclanguage=en)
- OECD (2015), Guidance Document on Elements of a PRTR: Part II, ENV/JM/MONO(2015)45, [http://www.oecd.org/officialdocuments/publicdisplaydocumentpdf/?cote=env/jm/mono\(2015\)45&doclanguage=en](http://www.oecd.org/officialdocuments/publicdisplaydocumentpdf/?cote=env/jm/mono(2015)45&doclanguage=en)
- OECD (2014b), Global Pollutant Release and Transfer Register, Proposal for a Harmonised List of Pollutants, ENV/JM/MONO(2014)32, [http://www.oecd.org/officialdocuments/publicdisplaydocumentpdf/?cote=env/jm/mono\(2014\)32&doclanguage=en](http://www.oecd.org/officialdocuments/publicdisplaydocumentpdf/?cote=env/jm/mono(2014)32&doclanguage=en)
- OECD (2017a), Resource Compendium of PRTR Release Estimation Techniques Part III: Summary of Techniques for Estimating Quantities Transferred, Released or Disposed, ENV/JM/MONO(2017)1, [http://www.oecd.org/officialdocuments/publicdisplaydocumentpdf/?cote=env/jm/mono\(2017\)1&doclanguage=en](http://www.oecd.org/officialdocuments/publicdisplaydocumentpdf/?cote=env/jm/mono(2017)1&doclanguage=en)
- OECD (2017b), Resource Compendium of PRTR Release Estimation Techniques Part IV: Summary of Techniques for Estimating Releases of Chemicals from Products, ENV/JM/MONO(2017)2, [http://www.oecd.org/officialdocuments/publicdisplaydocumentpdf/?cote=env/jm/mono\(2017\)2&doclanguage=en](http://www.oecd.org/officialdocuments/publicdisplaydocumentpdf/?cote=env/jm/mono(2017)2&doclanguage=en)
- PRTR.net (2019), <https://prtr.unece.org/>.
- Swedish EPA (1998), Analysis of a European Polluting Emissions Register (EPER) (Swedish Environmental Protection Agency, Stockholm, Sweden).
- UNECE (2000), Pollutant Release and Transfer Registers, Report on the First Meeting of the Task Force, UN Economic and Social Council.
- UNITAR (1998), Guidance on Estimating Non-point Source Emissions, UNITAR Series PRTR Technical Support Materials – No. 3, <http://prtr.unitar.org/site/document/1264>. This guidance is currently undergoing revision, and the updated version is scheduled for release in 2020.
- UNITAR (2017), Collection of International Guidance Materials on PRTRs, <http://prtr.unitar.org/site/document/1270>.

6.5. General References

- EEA (1999), Environment in the European Union at the Turn of the Century (EEA, Copenhagen, Denmark), <https://www.eea.europa.eu/publications/92-9157-202-0>.
- EEA (2015), The European Environment – State and Outlook 2015 Synthesis Report (EEA, Copenhagen, Denmark), <https://www.eea.europa.eu/soer-2015/synthesis/report>.
- EEA (1999), Nutrients in European Ecosystems Environmental Assessment Report No. 4 (EEA, Copenhagen, Denmark), <http://edz.bib.uni-mannheim.de/daten/edz-bn/eua/00/enviassrp04.pdf>.
- Statistics Norway (2018), Natural Resources and the Environment (Statistics Norway, Oslo, Norway), <https://www.ssb.no/a/en/histstat/kap02.html>.

References

- CARB (1991), *Identification of Particulate Matter Species Profiles, ARB Speciation Manual, Volume 2.* [22]
- CARB (1991), *Identification of Volatile Organic Compound Species Profiles, ARB Speciation Manual, Volume 1,* <https://www.ourair.org/wp-content/uploads/CARB-VOC-Species-Profiles.pdf>. [21]
- Djurhuus, H. et al. (2013), *Environmental law and practice in Denmark: overview*, Bech-Bruun, Denmark, [https://uk.practicallaw.thomsonreuters.com/0-522-0619?lrTS=20170510075610490&transitionType=Default&contextData=\(sc.Default\)&firstPage=true&bhcp=1](https://uk.practicallaw.thomsonreuters.com/0-522-0619?lrTS=20170510075610490&transitionType=Default&contextData=(sc.Default)&firstPage=true&bhcp=1). [5]
- EC (2018), *JRC Reference Report on Monitoring of Emissions to Air and Water from IED Installations,* <http://dx.doi.org/10.2760/344197>. [6]
- EC (2015), *JRC Technical Report. Soil threats in Europe: status, methods, drivers and effects on ecosystem services,* https://esdac.jrc.ec.europa.eu/public_path/shared_folder/doc_pub/EUR27607.pdf. [4]
- EC (2013), *Diffuse water emissions in E-PRTR,* [http://fis.freshwatertools.eu/files/MARS_resources/Info_lib/Deltares\(2013\)Diffuse%20water%20emissions%20in%20E-PRTR%202013%20project%20report.pdf](http://fis.freshwatertools.eu/files/MARS_resources/Info_lib/Deltares(2013)Diffuse%20water%20emissions%20in%20E-PRTR%202013%20project%20report.pdf). [26]
- EC (2012), *Guidance Document No. 28: Technical guidance on the preparation of an inventory of emissions, discharges and losses of priority and priority hazardous substances.* [31]
- EC (2011), *Methodology development for the spatial distribution of the diffuse emissions in Europe,* https://www.eea.europa.eu/data-and-maps/data/european-pollutant-release-and-transfer-register-e-prtr-regulation-art-8-diffuse-air-data/methodology-report/diffuse_releases_e-prtr_methodology_2011_en.pdf. [25]
- EEA (2019), *Chemicals in European waters,* <https://www.eea.europa.eu/publications/chemicals-in-european-waters>. [32]
- EEA (2016), *EMEP/EEA air pollutant emission inventory guidebook - 2016,* <https://www.eea.europa.eu/publications/emep-eea-guidebook-2016>. [9]
- Environment Australia (1999), *Australian NPI Emission estimation technique manuals,* <http://www.npi.gov.au/reporting/industry-reporting-materials/emission-estimation-technique-manuals>. [14]
- Environment Canada (2013), *Manual for the Compilation of Canada's 2013 Air Pollutant Emissions,* http://publications.gc.ca/collections/collection_2013/ec/En14-87-2013-eng.pdf. [30]
- EPAV (1999), *Measurements of Motor Vehicle Pollutants and Fleet Average Emission Factors in Melbourne,* EPA, Australia. [15]
- EPAV (1998), *Port Phillip Air Emissions Inventory,* http://www.epa.vic.gov.au/air/emissions_inventory/default.asp. [27]
- EPAV (1996), *National Pollutant Inventory: Technical Report on the Air Emissions Trials for the NPI, Volume 2,* Commonwealth of Australia. [24]
- EPAV (1991), *Air Emissions Inventory Port Phillip Control Region: Planning for the Future,* EPA, Australia. [23]

- IPCC (2006), *2006 IPCC Guidelines for National Greenhouse Gas Inventories*, IGES, Japan, [13]
<https://www.ipcc-nggip.iges.or.jp/public/2006gl/>.
- IPCC (2000), *IPCC Report on Good Practice Guidance and Uncertainty Management in National Greenhouse Gas Inventories*, IPCC Technical Support Unit, [29]
http://agrienvarchive.ca/bioenergy/download/ipcc_ghg_inv.pdf.
- NERI (2000), *Benzene from Traffic*, Ministry of Environment and Energy, National Environmental Research Institute, Denmark, [16]
http://www2.dmu.dk/1_Viden/2_publicationer/3_fagrappporter/rapporter/fr309.pdf.
- NSW EPA (2000), *Comparison of Selected Models to Estimate Nutrient Loadings*, New South Wales EPA, Australia, [28]
- NSW EPA (1999), *Review of Techniques to Estimate Catchment Exports*, New South Wales, EPA, Australia, [8]
<http://www.npi.gov.au/system/files/resources/ac997f84-17a2-f724-6def-bd3a47b9e4b4/files/nswreport.pdf>.
- OECD (2017), *Resource Compendium of PRTR Release Estimation Techniques Part IV: Summary of Techniques for Estimating Releases of Chemicals from Products*, [17]
[http://www.oecd.org/officialdocuments/publicdisplaydocumentpdf/?cote=env/jm/mono\(2017\)2&doclanguage=en](http://www.oecd.org/officialdocuments/publicdisplaydocumentpdf/?cote=env/jm/mono(2017)2&doclanguage=en).
- OECD (1999), *Proceedings of the OECD International Conference on Pollutant Release and Transfer Registers (PRTRs): National and Global Responsibility*, OECD [ENV/JM/MONO(99)16/PART1], [1]
 [ENV/JM/MONO(99)16/PART2],
[http://www.oecd.org/officialdocuments/publicdisplaydocumentpdf/?doclanguage=en&cote=env/jm/mono\(99\)16/part1](http://www.oecd.org/officialdocuments/publicdisplaydocumentpdf/?doclanguage=en&cote=env/jm/mono(99)16/part1).
- UNITAR (2017), *Collection of International Guidance Materials on Pollutant Release and Transfer Registers*, <http://prtr.unitar.org/site/document/1270>, [3]
- UNITAR (1998), *Guidance on Estimating Non-Point Source Emissions*, UNITAR Series PRTR Technical Support Materials – No. 3, <http://prtr.unitar.org/site/document/1264>, [2]
- US EPA (1999), *Handbook for Criteria Pollutant Inventory Development: A Beginner's Guide for Point and Area Sources*, [10]
<https://nepis.epa.gov/Exe/ZyNET.exe/P1000MVP.TXT?ZyActionD=ZyDocument&Client=EPA&Index=1995+Thru+1999&Docs=&Query=&Time=&EndTime=&SearchMethod=1&TocRestrict=n&Toc=&TocEntry=&QField=&QFieldYear=&QFieldMonth=&QFieldDay=&IntQFieldOp=0&ExtQFieldOp=0&XmlQuery=>.
- US EPA (1999), *Residential and Commercial/Institutional Natural Gas and LPG Combustion, Area Source Method Abstract from Volume III of EIIP Document Series*, <https://www.epa.gov/air-emissions-factors-and-quantification/ap-42-compilation-air-emissions-factors>, [20]
- US EPA (1997), *Guidance for Estimating Lawn and Garden Equipment Activity Levels, Chapter 3 from Volume IV of the EIIP Document Series*, <https://www.epa.gov/sites/production/files/2015-08/documents/iv03.pdf>, [7]
- US EPA (1995), *Compilation of Air Pollutant Emission Factors, Volume I, Stationary Point and Area Sources, AP-42*, <https://www.epa.gov/air-emissions-factors-and-quantification/ap-42-compilation-air-emissions-factors>, [11]

- US EPA (1992), *Procedures for Emission Inventory Preparation, Volume IV: Mobile Sources*, [19]
<https://nepis.epa.gov/Exe/ZyPDF.cgi/P1009ZEK.PDF?Dockey=P1009ZEK.PDF>.
- US EPA (1985), *Compilation of Air Pollutant Emission Factors, volume II, Mobile Sources, AP-42*. [18]
- US EPA (1985), *Compilation of Air Pollutant Emission Factors, Volume II, Mobile Sources, AP-42*, [12]
<https://www.epa.gov/moves>.

Annex A. KEY CONTACT ORGANISATIONS

The following organisations have major responsibility for preparing non-point source inventories for emissions to air and water.

COUNTRY	AIR INVENTORIES	INVENTORIES ON DISCHARGES TO WATER	NATIONAL GOVERNMENT CO-ORDINATING AGENCY
Australia	State and Territory EPAs	State and Territory EPAs;	Environment Australia
Austria	Federal Environment Agency Austria	Federal Environment Agency Austria	*
Belgium	Flemish Environment Agency	Flemish Environment Agency	-
Canada	Environment Canada	Environment Canada	Environment Canada
Denmark	National Environmental Research Institute; RISOE National Laboratory		
EU	EEA	EEA	EC
France	CITEPA	IFEN	Ministry of Ecology and Sustainable Development
Finland	Finnish Environment Institute	Finnish Environment Institute	
Germany	Umweltbundesamt	Umweltbundesamt	*
Greece	Ministry of the Environment	Ministry of the Environment	*
Ireland	Environmental Protection Agency	Environmental Protection Agency	*
Italy	National Environmental Protection Agency		
Japan	*	*	*
Netherlands	Ministry VROM-Inspectorate	Ministry VROM-Inspectorate	Ministry VROM-Inspectorate
New Zealand	Local municipalities		
Norway	Norwegian Institute of Air Research; Statistics Norway	Norwegian Institute of Water Research; Norwegian Centre for Soil and Environmental Research	Norwegian Pollution Control Authority
Portugal	Instituto do Ambiente (Portuguese Environmental Institute)	Instituto da Água (Portuguese Water Institute)	Instituto do Ambiente (Portuguese Environmental Institute)
Spain	*	*	*
Sweden	Swedish EPA	Swedish EPA	Swedish EPA
Switzerland	*	*	
United Kingdom	AEA Technology	*	DEFRA
United States	US EPA	US EPA	US EPA

Note: * Information not located

Annex B. INVENTORY SOURCE CATEGORIES

EMEP/EEA Air Pollutant Emission Inventory Guidebook 2016 (EEA, 2016^[9])

Note: The following sectors often include source categories that involve both point source and non-point (area and mobile) source air emissions estimation techniques. In some cases, particularly relating to industrial sources, a source category can be treated as a number of point sources or collectively as area sources, or as a combination of both. The source categories listed below under each sector are those most likely to be treated as non-point sources. In addition, the section numbering skips since the present version reproduces/updates information from earlier editions only to the extent that the information continues to be relevant.

1. Energy

- 1.A Combustion
- 1.B Fugitive emissions from fuels

2. Industrial processes and product use

- 2.A Mineral products
- 2.B Chemical industry
- 2.C Metal production
- 2.D-2.L Other solvent and product use

3. Agriculture

- 3.B Manure management
- 3.B Manure management
- 3.D Crop production and agricultural soils
- 3.D.f, 3.I Agriculture other including use of pesticides
- 3.F Field burning of agricultural wastes

5. Waste

- 5.A Solid waste disposal on land
- 5.B.1 Composting
- 5.B.2 Anaerobic digestion at biogas facilities
- 5.C.1.a Municipal waste incineration
- 5.C.1.b Industrial waste incineration including hazardous waste and sewage sludge
- 5.C.1.b.iii Clinical waste Incineration
- 5.C.1.b.v Cremation
- 5.C.2 Open burning of waste

- 5.D Wastewater handling
 - 5.E Other waste
6. Other sources
- 6.A Other sources
11. Natural sources
- 11.A Volcanoes
 - 11.B Forest fires
 - 11.C Other natural sources

Compilation of Air Pollutant Emission Factors, Volume I, Stationary Point and Area Sources, AP-42 (US EPA, 1995-2018)

Note: Similar comments apply as for the EMEP/EEA manual. Several of the following sectors largely relate to point sources. Source categories listed for each sector are those most likely to be treated as non-point sources.

The Fifth Edition of AP-42 was published in 1995, with updates and supplements to the fifteen chapters of Volume I published over time.

1. External combustion sources
 - Bituminous and sub-bituminous coal combustion
 - Anthracite coal combustion
 - Fuel oil combustion
 - Natural gas combustion
 - LPG combustion
 - Residential fireplaces
 - Residential wood stoves
2. Solid waste disposal
 - Refuse combustion
 - Landfills
 - Open burning
3. Stationary internal combustion sources
4. Evaporation source losses
 - Dry cleaning
 - Surface coating
 - Waste paper collection, treatment and storage
 - Asphalt paving operations

- Solvent degreasing
 - Graphic arts
 - Commercial/consumer solvent use
5. Petroleum industry
- Transportation and marketing of petroleum liquids
 - Organic chemical process industry
 - Liquid storage tanks
 - Inorganic chemical industry
 - Food and agricultural industries
 - Tilling operations
 - Growing operations (fertilisers, pesticides etc.)
 - Harvesting operations
 - Livestock and poultry feed operations
 - Agricultural wind erosion
10. Wood products industry
11. Mineral products industry
12. Metallurgical industry
- Miscellaneous sources
- Wildfires and prescribed burning
 - Fugitive dust sources
 - Explosives detonation
14. Greenhouse gas biogenic sources
- Emissions from soils
 - Termites
 - Lightning emissions

US EPA EIIP Technical Report Series, Volumes 1-10 (US EPA, 1995-2007)

Volume I: Introduction

Volume II: Point sources

Volume III: Area sources

- Introduction
- Residential wood combustion
- Architectural surface coating

- Dry cleaning
- Consumer and commercial solvent use
- Solvent cleaning
- Graphic arts
- Industrial surface coatings
- Pesticides – agricultural and non-agricultural
- Agricultural operations (not yet available)
- Gasoline marketing
- Marine vessel loading, ballasting and transit
- Autobody refinishing
- Traffic markings
- Municipal landfills
- Open burning
- Asphalt paving
- Structure fires

Method abstracts:

- Baked goods at commercial/retail bakeries
- Residential and commercial/institutional coal combustion
- Residential and commercial/institutional fuel oil and kerosene combustion
- Residential and commercial/institutional natural gas and LPG combustion
- Vehicle fires

Volume IV: Mobile sources

- Preferred and alternate methods for gathering and locating specific emissions inventory data
- Use of locality-specific transportation data for the development of mobile source emission inventories
- Guidance for estimating lawn and garden equipment activity levels

Volume V: Biogenic sources

- Biogenic sources preferred methods

Volume VI: Quality assurance procedures

Volume VII: Data management procedures

Volume VIII: Estimating greenhouse gas emissions

- Introduction
- Combustion of fossil fuels
- Industrial processes
- Natural gas and oil systems
- Coal mining
- Municipal waste disposal
- Domesticated animals
- Manure management
- Flooded rice fields
- Agricultural soils
- Forest management
- Burning of agricultural crop wastes
- Municipal wastewater
- Mobile combustion (CH₄ and N₂O)
- Stationary combustion (CH₄ and N₂O)

Volume IX: Particulate emissions

- Getting started: planning for a PM_{2.5} inventory

Volume X: Emission projections

The Netherlands Emissions Inventory²⁷: Non-point sources included for releases to air, water and soil

Note: Sources of emissions of ozone depleting substances are not included here.

1. Energy

- Fuel combustion
 - Energy industries
 - Manufacturing industries and construction
 - Transport

²⁷ <http://www.emissieregistratie.nl/erpubliek/bumper.en.aspx>

- Other sectors
 - Other
 - Fugitive emissions from fuels
 - Solid fuels
 - Oil and natural gas
 - CO₂ transport and storage
2. Industrial processes
- Mineral industry
 - Cement production
 - Glass production
 - Other process uses of carbonates
 - Chemical industry
 - Ammonia production
 - Nitric acid production
 - Caprolactam production
 - Petrochemical and carbon black production
 - Soda ash production
 - Metal industry
 - Iron and steel production
 - Aluminium production
 - Non-energy products from fuels and solvent use
 - Lubricant use
 - Paraffin wax use
 - Electronic industry
 - Product uses as ODS substitutes
 - Other product manufacture and use
 - Other
3. Agriculture
- Enteric fermentation
 - Manure management
 - Rice cultivation
 - Agricultural soils
 - Prescribed burning of savannas

- Field burning of agricultural residues
 - Liming
 - Urea application
 - Other carbon-containing fertilizers
 - Other
4. Land use, land-use change, and forestry
- Forest land
 - Cropland
 - Wetlands
 - Settlements
 - Other land
 - Harvested wood products
 - Other
5. Waste
- Solid waste disposal
 - Biological treatment of solid waste (composting)
 - Incineration and open burning of waste
 - Wastewater treatment and discharge
 - Other
6. Other

The Australian National Pollutant Inventory: Aggregated emissions sources (Environment Australia, 1999-2003)

Methodology handbooks have been prepared for the following source categories and are available on the NPI website:

- Aircraft
- Aquaculture - Temperate
- Aquaculture – Tropical
- Architectural coatings
- Barbecues
- Bushfires and Prescribed Burning
- Commercial Ships/Boats and Recreational Boats
- Cutback bitumen

- Domestic/commercial solvents and aerosols
- Dry cleaning
- Fuel Combustion (Sub-Threshold)
- Gaseous fuel burning – Domestic
- Industrial solvents use
- Lawn mowing - Domestic
- Motor vehicles
- Motor vehicle refinishing
- Paved and unpaved roads
- Printing and graphical arts
- Railways
- Service stations
- Solid fuel burning – Domestic

EIPCCB (European Integration Pollution Prevention and Control Bureau) Best Available Techniques Reference Documents

Reference Documents on Best Available Techniques have been prepared including the following source categories and are available on the EIPPCB website²⁸:

- Ceramic Manufacturing Industry
- Common Wastewater and Waste Gas Treatment/Management Systems in the Chemical Sector
- Emissions from Storage
- Energy Efficiency
- Ferrous Metals Processing Industry
- Food, Drink and Milk Industries
- Industrial Cooling Systems
- Intensive Rearing of Poultry or Pigs
- Iron and Steel Production
- Large Combustion Plants
- Large Volume Inorganic Chemicals – Ammonia, Acids and Fertilisers
- Large Volume Inorganic Chemicals – Solids and Others Industry

²⁸ <https://eippcb.jrc.ec.europa.eu/reference/>

- Management of Tailings and Waste-rock in Mining Activities
- Manufacture of Glass
- Manufacture of Organic Fine Chemicals
- Non-ferrous Metals Industries
- Production of Cement, Lime and Magnesium Oxide
- Production of Chlor-alkali
- Production of Large Volume Organic Chemicals
- Production of Polymers
- Production of Pulp, Paper and Board
- Production of Speciality Inorganic Chemicals
- Production of Wood-based Panels
- Refining of Mineral Oil and Gas
- Slaughterhouses and Animals By-products Industries
- Smitheries and Foundries Industry
- Surface Treatment of Metals and Plastics
- Surface Treatment Using Organic Solvents
- Tanning of Hides and Skins
- Textiles Industry
- Waste Incineration
- Waste Treatment

Annex C. EMISSIONS INVENTORIES THAT INCLUDE NON-POINT SOURCES

C.1. Introduction

An important reason for the widespread development of air pollutant inventories and inventories on discharges to water has been the existence of various inter-country and international reporting requirements that have been set up to address transboundary and global environmental problems involving air and water pollution and public access to information. Many of these conventions recognise cross-media links, particularly the atmospheric deposition of nitrogen (via NO_x and NH₃) into waterbodies. The most important transboundary reporting obligations, current and future, are summarised in Section D.2.

There is a variety of national and international emissions inventories that include data from non-point sources. This chapter presents a brief description of some of the existing inventories under which estimation techniques for non-point sources of pollution can be found. In most cases, these inventories are specific to a particular medium (*i.e.* air or water). They are considered ‘comprehensive’ in the sense that they attempt to include all significant point and non-point sources.

Figure A C.1 illustrates how a PRTR programme could be used to interface with and integrate non-point source data already collected by government bodies at the local, national and international level. That is, the PRTR could provide the "front end" for a range of inventories. Furthermore, the reporting processes, data acquisition measures and databases used for different inventories and for PRTRs overlap to a great extent, and this should be explicitly recognised by both the developers of PRTRs and by those conducting other inventory programmes. Recognising these overlaps and commonalities should enable consistency between the various inventory activities and minimise the time and resources required for the integration of non-point sources into PRTRs. A complementary approach to the non-point source specific techniques presented in Chapter 4 would be to consider other national and international inventory and reporting requirements that have to be met and to see if these requirements can be integrated into or otherwise combined with PRTR activities.

To date, few non-point source inventories have been incorporated into, or integrated with, national PRTR systems. The Netherlands Emissions Inventory is one of the few integrated systems in terms of media, as well as point and non-point sources. The Inventory was developed to serve government planning and policymaking, but is now evolving to make emissions data widely available, including emissions from individual industrial sources. The Australian NPI is developing along similar lines, although non-point emissions are limited geographically (*i.e.* by airshed or by catchment area). Another example is E-PRTRs. Their website²⁹ allows users locate air and water pollutant emissions from diffuse sources with zoom in and out function.

²⁹ ²⁹ See <https://prtr.eea.europa.eu/#/diffemissionsair> and <https://prtr.eea.europa.eu/#/diffemissionswater>.

Figure A C.1. Relationship between inventories, reporting requirements and PRTRs

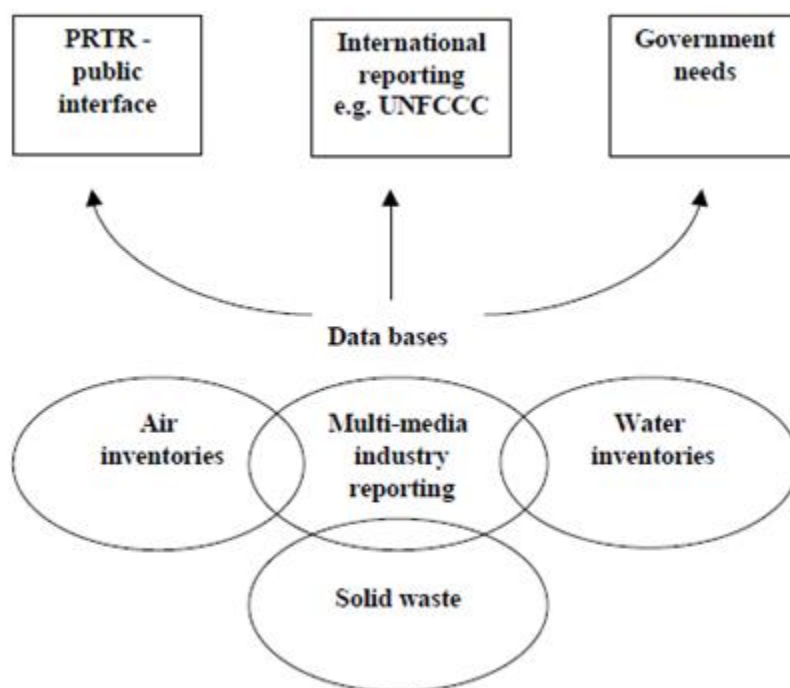

C.2. Transboundary reporting requirements

This section summarises international conventions that include non-point release data.

A.D.2.1. Convention on Long Range Transboundary Air Pollution (CLRTAP) 1979

Under the LRTAP Convention, Parties report emissions of NO_x (as nitrogen dioxide (NO₂), NMVOCs, SO_x (as SO₂), NH₃, CO, HMs, POPs and primary PM. Reporting obligations under the LRTAP Convention and EU's revised 2016 National Emission Ceilings Directive have now been harmonised. Parties to the convention report also every four years projection data, gridded data and large point source data.

Since 1984, eight protocols of the UNECE's Convention on LRTAP have come into force. Table A C.1 presents the ratification status of each protocol across the EU as a whole. The status differs across EU Member States.

Table A C.1. EU ratification status of the LRTAP Convention and related protocols

Year	LRTAP Convention and its protocols	Ratification status
1979	'Geneva Convention': Convention on Long-range Transboundary Air Pollution	Signed and ratified (approval)
1984	'Geneva Protocol': Protocol on Long-term Financing of the Cooperative Programme for Monitoring and Evaluation of the Long-range Transmission of Air Pollutants in Europe	Signed and ratified (approval)
1985	'Helsinki Protocol': Protocol on the Reduction of Sulphur Emissions or their Transboundary Fluxes by at least 30 per cent	Not signed
1988	'Sofia Protocol': Protocol concerning the Control of Emissions of Nitrogen Oxides or their Transboundary Fluxes	Ratified (accession)
1991	'Geneva Protocol': Protocol concerning the Control of Emissions of Volatile Organic Compounds or their Transboundary Fluxes	Signed
1994	'Oslo Protocol': Protocol on Further Reduction of Sulphur Emissions	Signed and ratified (approval)
1998	'Aarhus Protocol': Protocol on Persistent Organic Pollutants	Signed and ratified (approval)
1998	'Aarhus Protocol': Protocol on Heavy Metals	Signed and ratified (approval)
1999	'Gothenburg Protocol': Protocol to Abate Acidification, Eutrophication and Ground-level Ozone	Ratified (accession)
2012	Amendments to the Gothenburg Protocol	Ratified

Source: <http://www.unece.org/fileadmin/DAM/env/lrtap/welcome.html>

In May 2012, the Executive Body of the LRTAP Convention adopted amendments to the Gothenburg Protocol. The protocol's new text includes national emission reduction commitments for the major air pollutants NO_x, NMVOCs, SO_x and NH₃, as well as for primary PM_{2.5} (and BC as a component of PM). Countries are to achieve them in 2020 and beyond.

In 2012, the Executive Body also decided that adjustments to emission-reduction commitments, or to inventories for the purpose of comparing them with total national emissions, may be applied in certain circumstances, if such a circumstance keeps a Party from meeting one of its reduction commitments. The EMEP Steering Body reviews any supporting documentation and assesses whether or not the adjustment is consistent with the circumstances and guidance for adjustments. It makes the review available to the Parties, which have the option of making a submission to the Implementation Committee under Decision 2006/2.

In May 2014, the Executive Body adopted revised Guidelines for reporting emissions and projections data under the Convention on Long-range Transboundary Air Pollution³⁰. Parties are to apply them in 2015 and subsequent years. The deadline for individual Parties to submit data to the LRTAP Convention is 15 February each year. There is a separate deadline of 15 March for submitting the accompanying inventory reports. For the EU the reporting guidelines allow time to compile an aggregated inventory based on the individual submissions from Member States, i.e. the EU should submit EU inventory data to the Executive Secretary of the UNECE by 30 April each year, and the accompanying inventory report by 30 May. The reporting guidelines also request Parties to report emission inventory data using the new EMEP NFR14 format.

The Co-operative Programme for Monitoring and Evaluation of the Long-Range Transmission of Air Pollutants in Europe was formed by a Protocol under the CLRTAP, and a Task Force on Emission Inventories and Projections (TFEIP) has been established to review current inventories and reporting procedures. The TFEIP objectives are to:

³⁰ UNECE, 2014, Guidelines for reporting emissions and projections data under the Convention on Long-range Transboundary Air Pollution, United Nations Economic Commission for Europe (ECE/EB.AIR/125) (http://www.ceip.at/fileadmin/inhalte/emep/2014_Guidelines/ece.eb.air.125_ADVANCE_VERSION_reporting_guidelines_2013.pdf).

- provide a technical forum to discuss, exchange information and harmonise emission inventories;
- evaluate, in depth, existing emission factors and methodologies being used; and
- co-operate with other international organisations working on emissions inventories with the aim of harmonising methodologies and avoiding duplication.

Parties to the convention are recommended to review and apply the information contained in the regularly updated EMEP/EEA Air Pollutant Emission Inventory Guidebook when compiling their emission inventory data sets. The current edition of the Guidebook was finalised in 2019³¹.

A.D.2.2 European Pollutant Release and Transfer Register (E-PRTR)

The E-PRTR Regulation³² was adopted in 2006 to implement the Kiev Protocol at EU level.

The European Pollutant Release and Transfer Register (E-PRTR)³³ is the Europe-wide register that provides easily accessible key environmental data from industrial facilities in 28 European Union Member States and in Iceland, Liechtenstein, Norway and Serbia.

The register contains data for some 35,000 industrial facilities covering 65 economic activities across Europe.

For each facility, information is provided concerning the amounts of pollutant releases to air, water and land as well as off-site transfers of waste and of pollutants in waste water from a list of 91 key pollutants including heavy metals, pesticides, greenhouse gases and dioxins for the year 2007 onwards. Some information on releases from diffuse sources is also available.

The first reporting year under the E-PRTR was 2007, for which the data were reported in June 2009. From 2010, Member States reported data to the E-PRTR by the end of March each year (i.e. 15 months after the reporting year) and, subsequent to this, the register website is updated every year. As of reporting year 2019, data will be reported by the end of November of the following year (i.e. 11 months after the reporting year). This is established under Implementing Decision 2018/1135³⁴.

A.D.2.3 United Nations Framework Convention on Climate Change (1992)

Using comparable agreed methodologies, parties to the UNFCCC must develop, periodically update and publish national inventories of anthropogenic emissions from sources and removals by sinks of all greenhouse gases not controlled by the Montreal Protocol (on ozone depletion). Parties must report each year (by 15 April for the previous year) on CO₂, CH₄, N₂O, PFCs, HFCs and SF₆. Reports are made on a sector-to-sector basis and are not facility-specific. Parties should also provide information on emissions of CO, NO_x, and NMVOCs and are encouraged to include information on SO₂. The UNFCCC

³¹ EMEP/EEA, 2019, EMEP/EEA air pollutant emission inventory guidebook — 2019, EEA Technical No 13/2019, European Environment Agency (<https://www.eea.europa.eu/publications/emep-eea-guidebook-2019>).

³² <https://eur-lex.europa.eu/legal-content/EN/TXT/PDF/?uri=CELEX:32006R0166&from=HR>

³³ <https://prtr.eea.europa.eu/#/home>

³⁴ <https://eur-lex.europa.eu/legal-content/EN/TXT/PDF/?uri=CELEX:32018D1135&from=EN>

requires parties to use the 2006 Guidelines for National Greenhouse Gas Inventories (IPCC, 2006). The first Guidelines for National Greenhouse Gas Inventories were finalised in 1995 through a co-operative programme by IPCC, OECD and IEA.

Parties may use different methods if they are considered to better reflect their national situation providing these methods are not inconsistent with IPCC Guidelines and are well documented. Continuing work is underway on a detailed common reporting format, guidance on good practices and managing uncertainties in inventories (IPCC, 2000^[29]).

A.D.2.4 Agreement between the USA and Canada on Air Quality (1991)

The general objective of this agreement is to control transboundary air pollution – directed specifically at reducing acid rain – between the two countries. This involves, *inter alia*, establishing objectives for limiting or reducing emissions of SO₂ and NO_x, exchanging information on emissions and producing regular progress reports.

A.D.2.5 OSPARCOM (1992)

The Oslo and Paris Commission applies to the Northeast Atlantic, including the North Sea, and integrates the Oslo Convention of 1972 and Paris Convention of 1974. The parties to the Commission are the EU, plus Norway, Iceland and Switzerland. The main goal is to protect the marine environment from pollution at sea and from land-based activities. The focus is on pollutant loads from major rivers, in particular nutrients but also metals and POPs. Parties are required to produce national progress reports and develop a common basis for measurement.

A.D.2.6 HELCOM (1988)

The Helsinki Convention applies to the Baltic Sea. The parties to the Convention are the relevant EU countries, the Baltic countries, Poland and Russia. The Convention covers nutrients, metals and POPs and aims to reduce the load of nutrients and other pollutants entering the Baltic Sea over a 10-year period.

A.D.2.7 MEDPOL (1976)

The Convention on Protection of the Mediterranean Sea includes recommendations on reducing nutrient inputs, monitoring programmes and an inventory of land-based sources. However, the Convention does not include specific reduction targets.

A.D.2.8 Bucharest Convention (1996)

This Strategic Action Plan for the Rehabilitation and Protection of the Black Sea also sets targets for reduction of nutrient loads.

A.D.2.9 European Inland Waters

Various inter-country agreements exist relating to pollution in major rivers and lakes. The most significant of these are:

- Rhine Action Programme;
- Elbe Action Programme;
- Strategic Action Plan for the Danube River Basin;

- Environmental Action Programme for Central and Eastern Europe; and
- UN Convention on the Protection and Use of Transboundary Watercourses and International Lakes (1992).

A.D.2.10 North American Inland Waters

Canada and the US have several treaties, conventions and agreements dealing with waters that flow along or across their boundaries, including:

- Boundary Waters Treaty (1909);
- Lake of the Woods Convention (1925);
- Rainy Lake Convention (1940);
- Columbia River Treaty (1961) and Protocol (1964);
- Skagit River Treaty (1984);
- St Lawrence Seaway Project (1952); and
- Great Lakes Water Quality Agreement (1972, 1978, 1987).

C.3. Regional Activities

The various transboundary reporting requirements described above effectively require or strongly encourage estimates of pollutant loads or pollutant releases from point and non-point sources. As a result, air emissions inventories exist in most European countries, Canada and the US, and inventories on discharges to water exist or are under development for all seas of direct concern to Europe, as well as for some inland waters in North America and Europe. Most inventories were developed in response to a particular agreement or convention or in efforts to estimate pollution loads along shared borders. This section focuses on regional activities and inventory programmes.

A.D.3.1. Air emissions

(a) North America

US EPA compiles and publishes a national air emissions inventory (NEI) every three years, with interim year updates also available. This includes the criteria air pollutants (CAPs), hazardous air pollutants (HAPs) and some greenhouse gases. As well as fulfilling reporting requirements for CLRTAP and UNFCCC, the inventory tracks changes following the Clean Air Act amendments of 1990. The NEI is created based on both regulatory and technical components. The Air Emissions Reporting Rule (AERR) is the rule that requires states and local air agencies, allows tribes to submit CAP emissions and provides the framework for voluntary submission of HAP and Greenhouse Gas emissions. The AERR requires agencies to report all sources of emissions, except fires and biogenic sources. Wildfires and prescribed burning emissions and activity data are encouraged but not required; the EPA makes estimates of these sources irrespective of whether data are provided by state, local, and tribal agencies. For mobile sources, air agencies are required to provide model inputs to the MOtor Vehicle Emissions System (MOVES). Sources are divided into large groups called “data categories”: stationary sources are “point” or

“nonpoint” (county totals) and mobile sources are either on-road (cars and trucks driven on roads) or non-road (locomotives, aircraft, marine, off-road vehicles and non-road equipment such as lawn and garden equipment). The AERR has emissions thresholds above which states must report stationary emissions as “point” sources with the remainder of the stationary emissions reported as “nonpoint” sources. The AERR changed the way these reporting thresholds work as compared to the regulations prior to the 2008 inventory year to make these thresholds “potential to emit” thresholds rather than actual emissions thresholds. The only exception to the potential to emit approach is for lead, for which the threshold is actual emissions. The emissions that states, locals, and tribes report are actual emissions, despite that the criterion for which sources to report is based on potential emissions. The AERR requires emissions reporting every year, with additional requirements every third year in the form of lower point source emissions thresholds, and 2014 is one of these third-year inventories.

The Emissions Inventory Improvement Programme (EIIP) is a joint programme of US EPA, state and local authorities. The programme promoted the development and use of standard procedures for collecting, calculating, storing, reporting and sharing air emissions data in the US. The EIIP has published inventory guidance documents in ten volumes, covering an introduction to the programme, point, area, mobile and biogenic sources, quality assurance and data management. While the EIIP programme ended in the early 2000s, the NEI program continues to improve and publish the methods for estimation of point, nonpoint, mobile, fires, and biogenic source emissions, in collaboration with other EPA programs and state and local agencies. The latest emissions inventory methods are published as part of the development materials for state, local, and tribal air agencies on EPA’s website for the upcoming 2017 NEI. Once the NEI is published, the methods are summarised in a Technical Support Document with extensive references to the documentation, spreadsheets, databases, and other tools used by the EPA and the regulated air agencies to estimate emissions.

In 1993, US EPA began developing the National Toxics Inventory (NTI), covering 188 HAPs. The NTI was the predecessor of the NEI. The 1996 NTI which was completed in the late 1990’s served as the basis for the 1996 National-Scale Air Toxics Assessment (NATA). NATA is EPA’s ongoing comprehensive evaluation of air toxics in the US. The latest assessment, the 2014 NATA, which is based on the 2014 NEI, was made available to the public in August 2018. The NEI utilises existing information, including some data from the Toxics Release Inventory (TRI). Both the NEI and NATA are integral parts of the Agency’s Integrated Urban Air Toxics Strategy and also support other programmes, such as the Great Waters Programme, which requires the estimation of atmospheric deposition of HAPs to specified water bodies.

Canada also compiles and publishes a national emissions inventory. Environment Canada, in collaboration with provincial governments, prepares this inventory. It includes criteria pollutants as well as some metals and POPs, consistent with CLRTAP reporting requirements. More detailed provincial data are available directly from the provinces. Environment Canada has compiled a *Manual for the Compilation of Canada’s Air Pollutant Emissions* (Environment Canada, 2013^[30]). The objective of the Manual is to summarise, consolidate and describe best available inventory methods from the US and Canada. The US MOBILE6 model has been adapted for use in Canada. Local inventories also exist in parts of Canada. One example is the inventory developed for the Greater Vancouver Regional District.

In both Canada and the US, the PRTRs (TRI and NPRI) form quite separate systems to the national air emissions inventories, with separate data collection, management and dissemination processes. The TRI and NPRI do not include many of the national air inventory pollutants. Minor links between these systems include the use of some TRI data in the NTI, and the inclusion of some (mostly mobile) non-point sources in NPRI.

(b) Europe

The CORINAIR programme (CORINE stands for CO-ordination d'INformation Environnementale) was established by the European Union (EU) in 1986, with the aim of compiling a co-ordinated inventory of atmospheric emissions from the original 12 member states. The main priority was acid deposition so the original inventory covered SO₂, NO_x and VOCs. Since then, several updates have been prepared in co-operation with EMEP and IPCC-OECD to assist the preparation of inventories needed to meet CLRTAP and UNFCCC reporting requirements.

The EU Member States are responsible for selecting the activity data, emission factors and other parameters used for their national inventories. Member States should also follow the reporting guidelines and apply the methodologies in the latest version of the EMEP/EEA Inventory guidebook, which is regularly updated³⁵. Parties are able to use other methodologies but must provide an explanation. There has been close cooperation between the IPCC, OECD and IEA to ensure compatibility between the joint EMEP/EEA and IPCC reporting formats.

Member States are also responsible for establishing QA and QC programmes for their inventories. Each inventory report should include a description of the QA and QC activities and recalculations.

Member States submit their national LRTAP inventories and inventory reports by participating in Eionet (European Environment Information and Observation Network). In addition, they take part in the annual review and commenting phase of the draft EU inventory report. Member States check their national data and information used in the inventory report and, if necessary, send updates. They also provide general comments on the inventory report.

The European Environment Agency helps the European Commission's DG Environment to compile the annual EU LRTAP inventory for the whole of the EU.

EEA activities include:

- overall coordination and management of the inventory compilation process;
- coordinating the activities of the EEA's European Topic Centre on Air Pollution, Transport, Noise and Industrial pollution (ETC/ATNI), which checks the data, compiles the inventory and writes the draft report;
- communication with the EC;
- communication with Member States;
- circulation of the draft EU emission inventory and inventory report; and

³⁵ <https://www.eea.europa.eu/publications/emep-eea-guidebook-2019>

- hosting the official inventory database and disseminating the data and inventory report on the web.

Since 2004, the EEA and EMEP have supported a separate annual quality review of emission data submitted by the countries. It provides findings for the countries each year in order to improve the quality of emission data reported. Each year, EMEP publishes a joint report summarising the review findings.

The European Commission formally submits the EU emission inventory data and this informative inventory report (IIR) to the EMEP via the Executive Secretary of the UNECE.

The main activities of the European Topic Centre on Air Pollution, Transport, Noise and Industrial Pollution (ETC ATNI's) regarding the EU's LRTAP Convention emission inventory include:

- initial checks, tests and a centralised review of Member State submissions in cooperation with the EMEP Centre on Emission Inventories and Projections (CEIP), and compiling results from those checks (status reports, country synthesis and assessment reports, country review reports);
- consulting with Member States (via the EEA) to clarify issues with the data and other information provided;
- preparing the gap-filled EU emission inventory by 30 April, based on Member State submissions (which the EC subsequently submits to the UNECE); and
- preparing the updated EU emission inventory and inventory report by 30 May.

The European Environment Information and Observation Network Eionet facilitates the work of the EEA and the ETC/ATNI. It comprises the EEA (supported by its European topic centres), a supporting network of experts from national environment agencies and other bodies that deal with environmental information. Member States are requested to use the tools of the Central Data Repository (CDR) of the Eionet Reportnet to make their LRTAP Convention submissions available to the EEA.

(c) Australia and New Zealand

Air emissions inventories have been compiled for most major urban areas in Australia and New Zealand over the last two decades. These have traditionally focused on the criteria air pollutants. In recent years, air inventories in Australia have started to be integrated with Australia's NPI, which includes both point and non-point sources and covers criteria pollutants as well as HAPs. Inventory methods generally reflect those used around the world, perhaps with a greater reliance on household surveys for area sources. Some emission factors have been derived locally, although there has been a significant reliance on US EPA data. Current RETs for non-point sources that are presented in handbooks and used for the NPI are available on Environment Australia's website. Greenhouse gas inventories are compiled independently by the Australian Greenhouse Office for the country and periodically for the states.

A.D.3.2 Water

In general, non-point inventories on discharges to water are much less centralised, far more heterogeneous and less well developed than air inventories. Pollutant load estimation and catchment modelling tend to be more catchment area-specific and considerable work is

undertaken by research groups, not always closely connected with government programmes. The great variability in approaches reflects a wealth of scientific approaches.

(a) North America

The US Clean Water Action Plan, released in 1998, identifies watersheds with the most critical water quality problems and focuses resources by providing funds to states and territories for the implementation of Watershed Restoration Action Strategies. To support these efforts, US EPA has developed a multipurpose environmental analysis system, *BASINS 4.1* (Better Assessment Science Integrating Point and Non-point Sources), for use by state, regional and local agencies in watershed and water quality studies. This integrates a GIS, national watershed data, environmental assessment and modelling tools into one package. It supports the development of total maximum daily loads, integrating both point and non-point sources across a watershed. A non-point source model component estimates land use-specific non-point source loadings for selected pollutants at a watershed or sub-watershed scale.

The US also has a programme to tackle non-point source pollution of coastal waters. Legislation requires 33 states and territories that participate in the National Coastal Zone Management Programme to develop Coastal Non-point Pollution Control Programmes.

(b) Europe

The Water Framework Directive (2000/60/EC) established a framework for the protection of inland surface waters, transitional waters, coastal waters and groundwater. It aims to prevent further deterioration, protect and enhance the status of aquatic ecosystems and, with regard to their water needs, terrestrial ecosystems and wetlands directly depending on the aquatic ecosystems. It promotes sustainable water use based on a long-term protection of available water resources. It also aims at enhanced protection and improvement of the aquatic environment, inter alia, through specific measures for the progressive reduction of discharges, emissions and losses of priority substances and the cessation or phasing-out of discharges, emissions and losses of priority hazardous substances. Lastly, it ensures the progressive reduction of pollution of groundwater and prevents its further pollution.

A general scheme setting out the principal sources, pathways and intermediates of emissions to water has been developed under the Water Framework Directive, for the inventory of emissions, discharges and losses of priority substances, as shown in Figure A C.2 (EC, 2012_[31]).

Figure A C.2 provides a way to compare emissions reported under different approaches – source-oriented, pathway-oriented and riverine load oriented. On the left-hand side of the figure, the principal sources of the pollutants are shown, representing groups of sources. Emissions, discharges or loads can follow different pathways, either directly to surface water or to other compartments of the environment (i.e. air, soil or groundwater), represented by the middle section of the figure. Emissions can be the result of losses during production or as a result of the use of products. Some of the waste water from industry and households is collected in a sewer system and treated in industrial waste water plants (P10) or UWWTPs (P8), as shown on the right-hand side of the figure. UWWTPs can be seen as a secondary source

Figure A C.2. Relationship between the different surface water compartments and pathways (P1-P13)

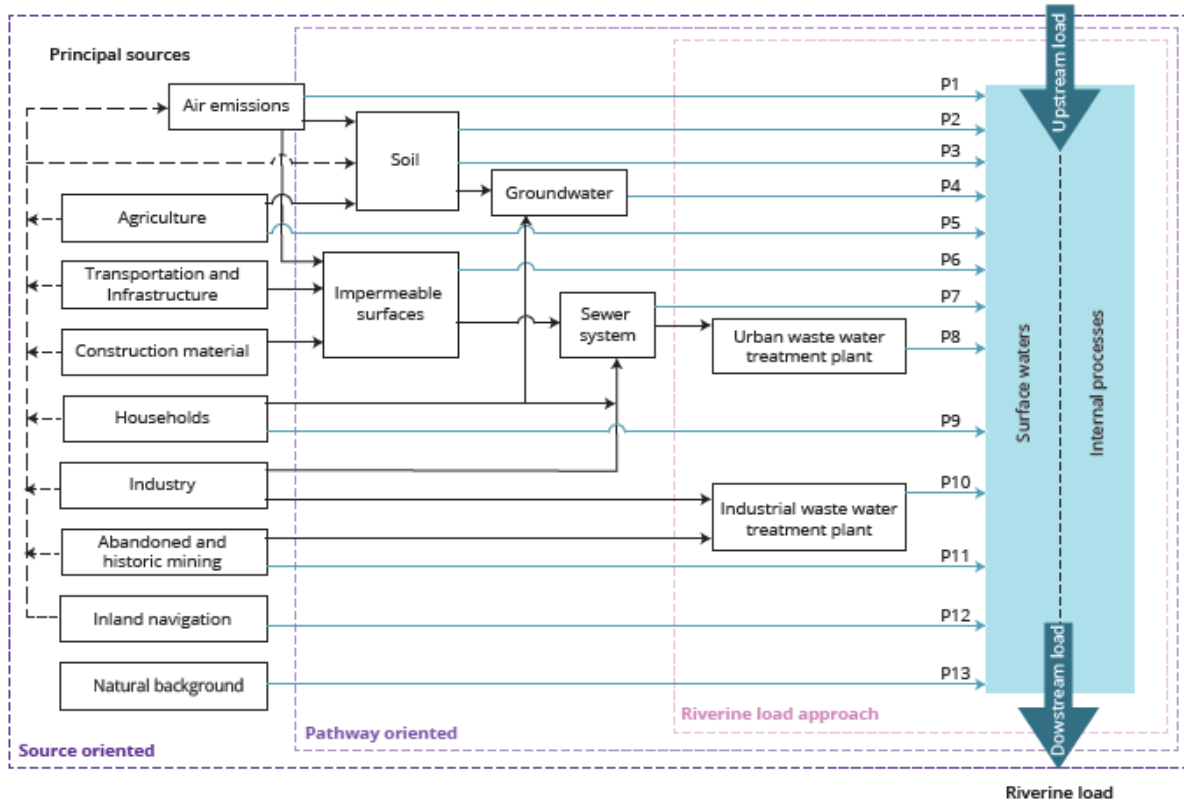

P1, Atmospheric deposition directly to surface water
 P2, Erosion
 P3, Surface run-off from unsealed areas
 P4, Interflow, tile drainage and groundwater
 P5, Direct discharges and drifting
 P6, Surface run-off from sealed areas
 P7, Stormwater outlets and combined sewer overflows and unconnected sewers

P8, Urban waste water treated
 P9, Individual (treated and untreated) household discharges
 P10, Industrial waste water treated
 P11, Direct discharges from mining
 P12, Direct discharges from navigation
 P13, Natural background

Source: EC, 2012.

In addition to E-PRTR data, collection of emissions to water is carried out by the EEA under its WISE-SoE emissions dataflow³⁶. Comparison of data collected under E-PRTR, WISE SoE and the Water Framework Directive is available (EEA, 2019^[32])

(c) Australia

Australia’s NPI incorporates estimates of non-point discharges to water in selected catchment areas. A relatively simple model, the Catchment Management Support System (CMSS), developed by CSIRO, is available as a default methodology³⁷. More complex models can be used where the necessary data are available. A report commissioned by Environment Australia (NSW EPA, 1999^[8]) identified 17 separate research groups

³⁶ See http://cdr.eionet.europa.eu/help/WISE_SoE/wise1.

³⁷ <http://www.toolkit.net.au/cmss>

involved in estimating nutrient emissions from non-point sources in Australia. These include government departments, universities and other research organisations, and consulting groups.

Annex D. CONVERSION TABLE OF DIFFERENT UNITS

U.S. Unit	multiplied by	Conversion Factor	equals	Metric Unit	U.S. Unit	multiplied by	Conversion Factor	equals	Metric Unit
Mass					Volume				
short tons (2,000 lb)	x	0.9071847	=	metric tons (t)	barrels of oil (b)	x	0.1589873	=	cubic meters (m ³)
long tons	x	1.016047	=	metric tons (t)	cubic yards (yd ³)	x	0.764555	=	cubic meters (m ³)
pounds (lb)	x	0.45359237 ^a	=	kilograms (kg)	cubic feet (ft ³)	x	0.02831685	=	cubic meters (m ³)
pounds uranium oxide (lb U ₃ O ₈)	x	0.384647 ^a	=	kilograms uranium (kgU)	U.S. gallons (gal)	x	3.785412	=	liters (L)
ounces, avoirdupois (avdp oz)	x	28.34952	=	grams (g)	ounces, fluid (fl oz)	x	29.57353	=	milliliters (mL)
					cubic inches (in ³)	x	16.38706	=	milliliters (mL)
Length					Area				
miles (mi)	x	1.609344 ^a	=	kilometers (km)	acres	x	0.40469	=	hectares (ha)
yards (yd)	x	0.9144 ^a	=	meters (m)	square miles (mi ²)	x	2.589988	=	square kilometers (km ²)
feet (ft)	x	0.3048 ^a	=	meters (m)	square yards (yd ²)	x	0.8361274	=	square meters (m ²)
inches (in)	x	2.54 ^a	=	centimeters (cm)	square feet (ft ²)	x	0.09290304 ^a	=	square meters (m ²)
					square inches (in ²)	x	6.4516 ^a	=	square centimeters (cm ²)
Energy					Temperature				
British thermal units (Btu)	x	1,055 05585262 ^a	=	joules (J)	degrees Fahrenheit (°F)	x	5/9 (after subtracting 32) ^a	=	degrees Celsius (°C)
calories (cal)	x	4.1868 ^a	=	joules (J)					
kilowatt-hours (kWh)	x	3.6 ^a	=	megajoules (MJ)					

^aExact conversion.
^bCalculated by the U.S. Energy Information Administration.
^cThe Btu used in this table is the International Table Btu adopted by the Fifth International Conference on Properties of Steam, London, 1956.
^dTo convert degrees Celsius (°C) to degrees Fahrenheit (°F) exactly, multiply by 9/5, then add 32.
 Note: Most metric units shown belong to the International System of Units (SI), and the liter, hectare, and metric ton are accepted for use with the SI units.
 Sources: General Services Administration, Federal Standard 3768, Preferred Metric Units for General Use by the Federal Government (Washington, DC, January 27, 1993), pp. 9–11, 13, and 16. National Institute of Standards and Technology, Special Publications 330, 811, and 814. American National Standards Institute/Institute of Electrical and Electronic Engineers, ANSI/IEEE Std 268-1992, pp. 28 and 29.

Source: US EIA, State Energy Data 2014, Appendix E, https://www.eia.gov/state/seds/sep_use/notes/use_e.pdf.