

Unclassified

ENV/JM/MONO(2008)14

Organisation de Coopération et de Développement Économiques
Organisation for Economic Co-operation and Development

17-Jul-2008

English - Or. English

**ENVIRONMENT DIRECTORATE
JOINT MEETING OF THE CHEMICALS COMMITTEE AND
THE WORKING PARTY ON CHEMICALS, PESTICIDES AND BIOTECHNOLOGY**

Cancels & replaces the same document of 30 June 2008

**OECD SERIES ON EMISSION SCENARIO DOCUMENTS
Number 18**

**EMISSION SCENARIO DOCUMENT FOR INSECTICIDES, ACARICIDES AND PRODUCTS TO
CONTROL OTHER ARTHROPODS FOR HOUSEHOLD AND PROFESSIONAL USES**

JT03249030

Document complet disponible sur OLIS dans son format d'origine
Complete document available on OLIS in its original format

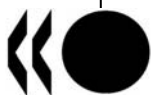

ENV/JM/MONO(2008)14
Unclassified

English - Or. English

OECD Environment, Health and Safety Publications

Series on Emission Scenario

No. 18

**EMISSION SCENARIO DOCUMENT (ESD) FOR
INSECTICIDES, ACARICIDES AND PRODUCTS TO CONTROL
OTHER ARTHROPODS FOR HOUSEHOLD AND
PROFESSIONAL USES**

IOMC

INTER-ORGANIZATION PROGRAMME FOR THE SOUND MANAGEMENT OF CHEMICALS

A cooperative agreement among UNEP, ILO, FAO, WHO, UNIDO, UNITAR and OECD

Environment Directorate

ORGANISATION FOR ECONOMIC CO-OPERATION AND DEVELOPMENT

Paris 2008

Explanatory Notes

Purpose and background

This ESD should be seen as a 'living' document, which provides the most updated information available. As such, an ESD can be updated to take account of changes and new information that becomes available. Users of the document are encouraged to submit comments, corrections, updates and new information to the OECD Environment, Health and Safety Division (richard.sigman@oecd.org). The comments received will be forwarded to the OECD Task Force on Biocides, which will review the comments and update the document. The submitted information will also be made available to users on the OECD web-site (www.oecd.org/env/biocides).

How to use this document

The user of this ESD needs to consider how the information contained in the document covers the situation for which they wish to estimate releases of chemicals. The document could be used as a framework to identify the information needed, or the approaches in the document could be used together with the suggested default values to provide estimates. Where specific information is available it should be used in preference to the defaults. At all times, the values inputted and the results should be critically reviewed to assure their validity and appropriateness.

The primary aim of this ESD is for use in risk assessments in notification and authorisation procedures in regulatory frameworks used in OECD countries.

How this document was developed

This Emission Scenario Document was prepared by Y. Maximilien, M-H. Enrici (AFSSET ^a) and S. Andres, F. Bouyé (INERIS ^b), France. The work was funded by the French Ministry for Ecology. The Expert Group on ESDs for Insecticides, a sub-group under the Task Force on Biocides, provided information and guidance in drafting of this document.

At the beginning of the project, a questionnaire was sent at the end of August 2005 to Industry in order to collect information directly from professionals involved in the production, distribution, marketing and application of these products. Questionnaires were also sent to governments to make them aware of the project and to collect existing databases on these products. The task consisted of describing all use instructions, as well as the modes of use of the treated articles in order to estimate the releases into air, soil and wastewater of the biocidal substances used as non-agricultural insecticides.

The expert Group on ESDs for Insecticides met on 5th October 2005 to discuss the outcome of the questionnaire and the structure of the scenario. CEFIC offered to complement the questionnaire with additional questions for describing professional uses. A new deadline for responding to the questionnaire was set to mid-November 2005.

^a AFSSET : French Agency for Environment and Occupational Health Safety

^b INERIS : French National Institute of Industrial Environment and Risks

On the basis of all available information, AFSSET and INERIS prepared a first version of the emission scenario document that covered spray application. This first version was discussed at the 3rd Expert Group meeting on Insecticides (10th February 2006). Comments on this draft have been received until May 30th on the basis of which a second version was prepared. This second draft includes spray applications, gels, diffusers, foggers, powders, bait stations, and mosquito nets. Some specific issues for outdoor uses (spot applications, secondary poisoning) were also added.

This draft ESD was discussed at the 4th Expert Group meeting on Insecticides (11th September 2006), and a deadline was set to October 30th for commenting this draft. In parallel, an electronic consultation was initiated on October 19th 2006 to the OECD expert group members in order to get their opinion about three main issues: inclusion of termites treatments in the ESD for insecticides, use of a simultaneity factor or tonnage data and the definition of the receiving compartment exposed during the outdoor application of insecticide by spray.

Based on responses to this electronic consultation and comments on the second draft, a third draft of the emission scenario document has been prepared and sent on March 2007. This last version includes fumigants, applications by dusting and injection.

This third draft was made available on the OECD protected website in April with a deadline for sending comments on May 16th. The same draft was also sent for comments to the members of the EU Technical Meeting on Biocides.

Modifications based on the comments received were included in the 4th draft ESD. This document was discussed at the 5th meeting of the Task Force on Biocides (20-21 September, 2007, Paris). No comment was received from the group on this version but two main issues remain:

- The relevance of the simultaneity factor which represents the number of building in which an insecticide can be simultaneously applied, at watershed level;
- The default value for the size the larger buildings (industrial, commercial, public...) that would need some refinement to take into to account the diversity and the specificity of the OECD countries.

This ESD takes into account the recommendations of the Task Force on Biocides. The sections needing a refinement have been flagged and will be reviewed as soon as more relevant data are available.

Table of contents

Chapter 1	Overview and purpose of this document	13
1.1	Steps identified for the life cycle of insecticides.....	14
Chapter 2	General information about non-agricultural insecticides and their application modes	16
2.1	Target organisms: insects and others arthropods.....	16
2.1.1	Cockroaches.....	16
2.1.2	Ants.....	17
2.1.3	Fleas.....	18
2.1.4	Flies	18
2.1.5	Mosquitoes.....	19
2.1.6	Wasps/hornets.....	19
2.1.7	Spiders	20
2.1.8	Dust mites	20
2.1.9	Bed bugs	20
2.1.10	Termites.....	21
2.2	Exposure route to insecticides for target organisms.....	23
2.2.1	By ingestion.....	23
2.2.2	By inhalation.....	23
2.2.3	By contact.....	23
2.3	The different forms of insecticides.....	23
2.3.1	Gas.....	23
2.3.2	Solids	23
2.3.3	Liquids.....	24
2.4	Materials and modes of application.....	25
2.4.1	Sprayers	25
2.4.2	Gel applicators.....	27
2.4.3	Dusters.....	27
2.4.4	Injection.....	28
2.4.5	Gas.....	30
2.4.6	Smoke generators.....	30
2.4.7	Diffusers	30
2.4.8	Foggers	33
2.4.9	Trap/baits.....	34
2.5	Users/applicators of biocidal insecticides	35
2.6	Building type	35
2.7	Simultaneity factor	38
Chapter 3	Indoor applications	41
3.1	Release pathways	41
3.2	Release estimations for mixing / loading step.....	42
3.3	Releases estimations for indoor applications	47
3.3.1	Spray application (1).....	47

3.3.2	Gel application (2)	55
3.3.3	Dusting (3)	56
3.3.4	Injection (4)	58
3.4	Emission models for indoor treatments	65
3.4.1	Application by spraying	65
3.4.2	Gel application	77
3.4.3	Application of powders by dusting	80
3.4.4	Indoor injection	87
3.4.5	Fumigant/gas	94
3.4.6	Diffusers	95
3.5	Releases at the local scale	96
3.5.1	Cleaning step	96
3.5.2	Summary:	101
Chapter 4	Scenarios for outdoor applications	102
4.1	Release pathways to the environment	102
4.2	Releases estimation for outdoor mixing/loading step	106
4.2.1	Receiving compartment	106
4.2.2	Emission factor	106
4.2.3	Size of the receiving compartment	106
4.2.4	Summary for the outdoor preparation step	107
4.3	Releases estimation for outdoor application scenarios	107
4.3.1	Spray application: Treatment around the building	107
4.3.2	Spray application: Treatment of crawling space	124
4.3.3	Spray application: Treatment of wasp or hornet nests	127
4.3.4	Spot application	128
4.4	Emission models for outdoor scenarios	134
4.4.1	Mixing/loading step	135
4.4.2	Spray application: Treatment around the building	136
4.4.3	Spray application: crawling space application	144
4.4.4	Spray application: Outdoor nest spray application	146
4.4.5	Spot application	147
Chapter 5	Exposure scenarios for secondary poisoning to wild birds and mammals	149
5.1	Introduction	149
5.2	First tier exposure assessment: general approach and calculation of the estimated theoretical exposition (ETE)	150
5.2.1	Residues in food	151
5.2.2	Identification of representative species	151
5.2.3	Estimated daily intake calculations	154
5.3	Second tier assessment: options for refinement	162
5.3.1	Daily food intake rate (FIR)	162
5.3.2	Concentration of active substance (C)	162
5.3.3	Multiple application factor (MAF)	162
5.3.4	Avoidance (AV)	162
5.3.5	Proportion of diet obtained in treated areas (PT)	163

5.3.6	Proportion of different food types in diet (PD).....	163
5.3.7	Biomagnification in terrestrial food chains	163
Chapter 6	References	164
Chapter 7	Appendices	167
7.1	Appendix 1: Some active substance in insecticide formulations	167
7.2	Appendix 2: Emission factors to the applicator during the application step by spraying .	171
7.3	Appendix 3: Estimates of fall – time for various droplet sizes	175
7.4	Appendix 4: Details emission factors to the applicator during the application step by spraying	175
7.5	Appendix 5: Summary of variables in text and equations.....	176

List of tables

Table 2.1-1: Termite treatment: scope of the emission scenario documents	22
Table 2.6-1: Average UK building size (HSE 1987)	38
Table 3.1-1 Receiving compartments for insecticide spray uses in indoor	41
Table 3.2-1 Names of the emissions factors during the mixing/loading step	43
Table 3.2-2: Emission factor to the applicator during the mixing loading step	45
Table 3.2-3: Emission factors to floor expressed as ml of commercial product per operation for containers with unspecific design (PSD 1992)	46
Table 3.2-4: Emission factors to floor expressed as ml of commercial product per operation for wide-necked container (PSD 1992)	46
Table 3.3-1: Review of the different emission factors to the applicator with regards to the kind of treatment and the type of spray used	50
Table 3.3-2: Emission factors to floor for air-space applications depending on the device used	52
Table 3.3-3: Emission factors to floor for the treatment of surfaces depending on the device used ...	53
Table 3.3-4: Emission factors to the treated surface depending of the type of treatment	54
Table 3.3-5: Review of the different emission factors for unspecified mode of spraying	54
Table 3.3-6: Calculation of the contamination during the insecticide injection (Cattani et al. 2001) ..	61
Table 3.3-7: Explanation of symbols	63
Table 3.3-8: Cleaning efficiency for different products used (CEFIC Insecticides Working Group)	64
Table 4.1-1: Environmental receiving compartments potentially exposed during the outdoor use of insecticides	105
Table 4.2-1: Receiving compartments for insecticide during the mixing/loading	106
Table 4.2-2: Default values for the outdoor preparation step.	107
Table 4.3-1: Receiving compartments for insecticide during spray application	110
Table 4.3-2: Receiving compartments of releases of insecticide during washing by rainwater	111
Table 4.3-3: Default values for treated surfaces during outdoor spray application around the house	113
Table 4.3-4: Default values for treated surfaces during outdoor spray application around the public, commercial, or industrial, i.e. large structures	113
Table 4.3-5: Default values for surface adjacent to the treated zone during outdoor spray application	114
Table 4.3-6: Emission factors to the untreated zone	117
Table 4.3-7: Default values for emission factors during outdoor spray application on walls against flying insects and during further wash-off by rainfall.	119
Table 4.3-8: Default values for emission factors during outdoor spray perimeter treatment against crawling insects and during further wash-off by rainfall	120

Table 4.3-9: Default values for the receiving compartment during outdoor spray application on walls against flying insects and further wash-off by rainfall.....	122
Table 4.3-10: Default values for the receiving compartment during outdoor spray perimeter treatment against crawling insects and further wash-off by rainfall.....	123
Table 4.3-11: Receiving compartments of the releases of insecticide during treatment of crawling space.....	124
Table 4.3-12: Default values for treated surfaces during outdoor spray application in the crawling space.....	125
Table 4.3-13: Default values for emission factors during crawling space spray application.....	126
Table 4.3-14: Receiving compartments for insecticide during spray applications to wasp and hornet nests.....	127
Table 4.3-15: Default values for the receiving compartment during spray application of the nests. .	128
Table 4.3-16: Environmental compartments potentially exposed relative to the use of outdoor gel application.....	129
Table 4.3-17: Environmental compartments potentially exposed relative to the use of outdoor bait stations.....	130
Table 4.3-18: Environmental compartments potentially exposed relative to the use of outdoor diffusers.....	131
Table 4.3-19: Environmental compartments potentially exposed relative to the use of powder on ant nests.....	132
Table 4.3-20: Default values for emission factor in treated surfaces during outdoor spot applications.....	133
Table 5.2-1: Indicator species representative of the lawn/garden and relevant for secondary poisoning.....	153
Table 5.2-2: Parameters for the calculation of the daily intake (first tier exposure assessment).....	154
Table 5.2-3: Parameters for the calculation of the concentration of substance in fresh diet.....	154
Table 5.2-4: Application rate calculation for wall and perimeter treatment.....	156
Table 5.2-5: Food intake rate (FIR) for indicator species of lawn/garden with parameters referenced in (Crocker et al. 2002).....	157
Table 5.2-6: Variables/parameter and default values of the standard emission scenario for the outdoor spray application.....	159
Table 5.2-7: Food intake rates per body weight (FIR/bw) for indicator species and residues values in contaminated vegetation and insects (normalised for an application rate of 1 kg active ingredient/ha).....	160
Table 5.2-8: Multiple Application Factors in acute and short-term exposures for residues on vegetation (SANCO/4145 2002).....	161
Table 7.2-1: Calculation of the contamination during an air space treatment with an aerosol dispenser (ACP - SC 11000 – consumer exposure to non agricultural pesticide products).....	171
Table 7.2-2: Calculation of the contamination during an air space treatment with a trigger spray (ACP - SC 11000 – consumer exposure to non agricultural pesticide products).....	171
Table 7.2-3: Calculation of the contamination during a surface treatment with an aerosol	

dispenser (ACP - SC 11000 – consumer exposure to non agricultural pesticide products)	172
Table 7.2-4: Calculation of the contamination during a surface treatment with a trigger spray (ACP - SC 11000 – consumer exposure to non agricultural pesticide products).....	173
Table 7.2-5: Calculation of the contamination during the use of compressed sprayer (1 to 3 bars): (HSE surveys 1992-3, IOM study on PPE, 1996)	174
Table 7.2-6: Calculation of the contamination during the use of compressed sprayer (4 to 7 bars): (Garrod et al. 1998).....	174
Table 7.3-1: Fall-time extracted from (Biocides_Steering_Group 1998) report	175
Table 7.4-1: Calculation of the emission to the application during a broadcast powder treatment: ACP - SC 11000 – consumer exposure to non agricultural pesticide products & (Bremmer et al. 2006).....	175

List of figures

Figure 1.1-1: Insecticide life cycle	14
Figure 2.4-1: In-can sprayer.....	25
Figure 2.4-2: A trigger sprayer	26
Figure 2.4-3: A knapsack sprayer	26
Figure 2.4-4: Compressed sprayers	27
Figure 2.4-5: An applicator gun for gel insecticide	27
Figure 2.4-6: A duster for powder insecticide	28
Figure 2.4-7: Insecticide soil injection treatment around the building	28
Figure 2.4-8: Insecticide floor treatment by injection	29
Figure 2.4-9: Insecticide floor treatment by injection	29
Figure 2.4-10: A smoke generator	30
Figure 2.4-11: An insecticide diffuser (WHOPES 2006)	31
Figure 2.4-12: An example of mat heater (WHOPES 2006)	32
Figure 2.4-13: Examples of electric liquid vaporizers (WHOPES 2006).....	32
Figure 2.4-14: a mosquito coil placed on a fireproof base (WHOPES 2006)	33
Figure 2.4-15: Cold fogging	33
Figure 2.6-1: Dimension of the typical private house.....	36
Figure 3.3-1: the wall treatment by injection.....	60
Figure 4.1-1: Release pathway foreseen for the outdoor use of insecticides.....	104
Figure 4.2-1 Receiving compartment during the mixing loading step outdoor.....	107
Figure 4.3-1: Schematic drawing of the house with the treated area.....	112
Figure 4.3-2: emissions pathways during spray application on walls against flying insects.....	115
Figure 4.3-3: emissions pathways during spray application on grounds and foundations against crawling insects	116
Figure 4.3-4: Schematic drawing of the house with the receiving compartments.....	121
Figure 4.3-5: default parameter for a crawling space	126
Figure 4.3-6: example of receiving compartment for spot application.....	133
Figure 4.4-1: Zone of direct application, deposition and run-off and untreated zone exposed to drift from ground application (crawling insects)	143
Figure 5.2-1: Ornamental garden plan (500m ²) from (Vosswinkel <i>et al.</i> 2003).....	151
Figure 7.1-2: Permethrin.....	168
Figure 7.1-3: General chemical structure of organophosphorous compounds	168
Figure 7.1-4: Dichlorvos.....	168
Figure 7.1-5: General chemical structure of carbamates	169
Figure 7.1-6: Propoxur.....	169

Chapter 1 Overview and purpose of this document

This Emission Scenario Document (ESD) is intended to provide information to be used for risk assessment for active substances and products used as biocidal (*i.e.* non agricultural) insecticides, acaricides and products to control other arthropods (in the EU, product type 18 [PT18] ^c). Biocidal products marketed as insecticides are used in many different applications. They may be used indoors (within buildings), outdoors (around buildings and beyond), in sewer systems, in food storage systems and for veterinary purposes in animal dwellings. The emission scenarios on insecticides for stable and manure storage systems were developed and finalised in 2005 (OECD 2005). In specific cases, there may be borderline cases ^d with plant protection products, food and feeding area disinfectants (EUBPD [98/8] product type 4 [PT4]), veterinary medicinal products (EUBPD [98/8] product type 3 [PT3]) or wood preservatives (EUBPD [98/8] product type 8 [PT8]). This can occur if a biocide is used for more than one purpose.

Finally the expert group on ESDs for insecticides has chosen to exclude all the insecticide treatments for vector control from the scope of the scenario, as these uses may need further investigations. A specific ESD relating to vector control applications may be developed at a later date.

^c For EU countries, "Product Type 18" – insecticides – is one of the 23 biocidal product types covered by the EU Directive 98/8/EC concerning the placing on the market of biocidal products (EU Biocidal Product Directive or EUBPD). Commission Regulations 2032/2003 and 1048/2005 list notified existing active substances under product type 18 which had to be submitted to the competent authority of the Rapporteur Member State no earlier than 1 November 2005 and no later than 30 April 2006.

^d In the EU, the borderlines with other EU directives and other product types are important issues and, in some cases, still being discussed. Readers should check the original borderline guidance documents (for instance EC, 2002). The Guidance Documents set the general rules and the Manual for Decisions summarise the discussions on various issues on a case-by-case basis. All documents are available on the website:
<http://europa.eu.int/comm/environment/biocides/index.htm>.

1.1 Steps identified for the life cycle of insecticides

The following steps were identified for the life cycle of insecticides:

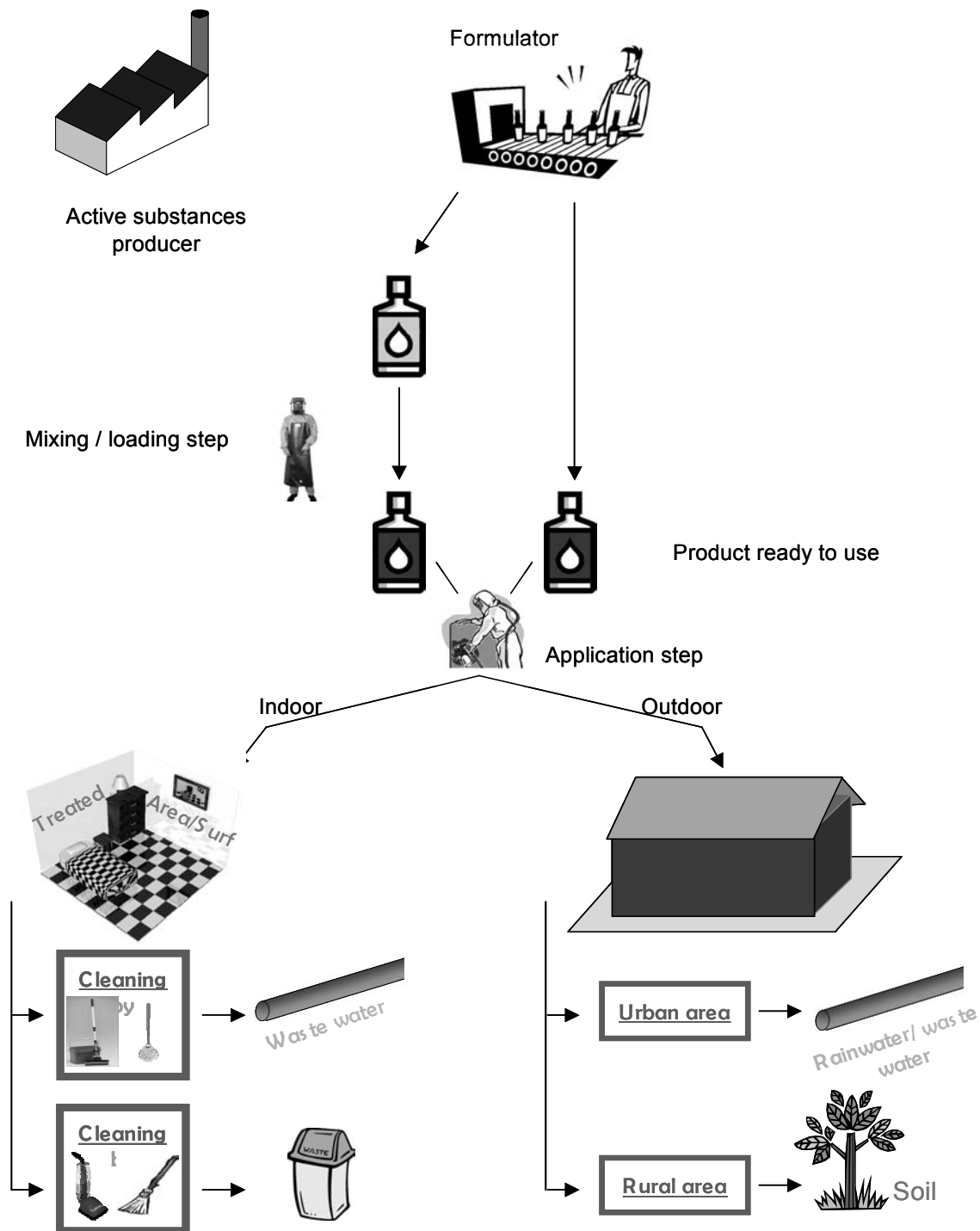

Figure 1.1-1: Insecticide life cycle

The scenario developed in this ESD on insecticides for household and professional uses covers the mixing/loading step, all kinds of possible releases during application, releases from indoor treated surfaces by cleaning events and outdoor treated surfaces by weathering.

The scenarios in this report are presented in the following way:

Input / Output

Variable/parameter	Symbol	Unit	Default	S/D/O/P
--------------------	--------	------	---------	---------

These parameters are the input to the scenario. The S, D, O or P classification of a parameter indicates the status:

- S Parameter must be present in the input data set as data requirement for the calculation to be executed (there has been no method implemented in the system to estimate this parameter, no default value is set).
- D Parameter has a default value (most defaults can be changed by the user)
- O Parameter is the output from another calculation (most output parameters can be overwritten by the user with alternative data).
- P Parameter value can be chosen from a “pick-list” of values
- ° Default or output parameter is closed and cannot be changed by the user

Intermediate calculation

Parameter description (Unit)

[Parameter = equation] (Eq. no.)

End calculations

[Parameter = equation] (Eq. no.)

Chapter 2 General information about non-agricultural insecticides and their application modes

2.1 Target organisms: insects and other arthropods

2.1.1 Cockroaches

The presence of cockroaches in the home undoubtedly causes more distress to home and apartment dwellers than nearly any other insect pest. Part of the distress in most cases is due to dislike of any visible indicators of poor domestic hygiene. In addition, there is a common perception that cockroaches live in homes that are not well kept, so there is also a negative stigma attached to their presence. A clean home will not sustain as many cockroaches as an identical home that is cluttered and dirty because there will be less food for the cockroaches to eat. Other factors, like humidity, and harbourage (i.e., cracks and crevices) are very important in influencing infestation levels. In addition to the distress caused by cockroaches within homes, there is little tolerance to their presence within restaurants and commercial enterprises where damage caused by the fouling and tainting of food-stuffs and non-food materials (i.e. hospital supplies) can occur.

The main reason for cockroaches to harbour and transmit diseases is that they live with us, eat just about anything, including food in our kitchen waste. Disease-causing bacteria (including *Salmonella*, *Staphylococcus* and *Streptococcus*) can potentially remain for several months in the cockroach digestive system. Also, species such as the German cockroach can transmit disease due to their habit of walking over and feeding on waste materials and subsequently walking over human food and food preparation areas. Human utensils and food could be contaminated with the cockroach faeces. Many people who suffer dust allergy could also develop an allergy to cockroaches. In infested homes, cockroach remains and faeces become a major constituent of house dust. Some people develop allergies after a long-term exposure to dust contaminated with cockroach remains such as scientists who work in laboratories where cockroaches are reared for experiments. Asthma can potentially be induced by repeated exposure to “cockroach dust”.

There are over 3,500 cockroach species in the world. Among the most representative species (Ogg *et al.*) are German cockroaches, which are generally considered the most troublesome species. German cockroaches usually prefer the indoor environment, as does the Brownbanded cockroach. Some cockroaches are known as “peridomestic” (indoor/outdoor) which are more closely related to each other than they are to the German cockroach. These species include the American cockroach, Smokybrown cockroach, and the Oriental cockroach (Miller *et al.* 2003).

- German cockroaches (*Blattella germanica*) are mostly nocturnal and are pests of warm, humid conditions. They cluster in groups within narrow harbourages close to where food and/or water are readily available. They are sometimes found near the electrical heat sources, like fan motors, refrigerator compressors.
- Brownbanded cockroaches (*Supella longipalpa*) are similar in size to the German cockroach. They could be found in similar situations to German cockroaches but also in bedrooms and living rooms (often towards the ceiling where temperatures are higher). They need lower moisture than the other species.

- Oriental cockroaches (*Blatta orientalis*) are mostly nocturnal and are pests of warm environments although they are tolerant of colder conditions. They are usually concentrated where the drinking water is available and the moisture is high (basement, bathroom, kitchen...). The oriental cockroach lives in dark, damp places like outdoor drains, water control boxes, woodpiles, basements, garages, garbage cans, and damp areas under houses.
- American cockroaches (*Periplaneta Americana*) are larger than Oriental cockroaches and are usually concentrated in the areas that are warm and moist (heating duct, boiling room...). They can be found in zoos and animal-rearing facilities, in sewers, steam tunnels, and masonry storm drains.
- Smokybrown cockroaches (*Periplaneta fuliginosa*) can be found occasionally in municipal sewers.

To control cockroaches, various formats of insecticidal products are available including liquids, traps, baits gels, self-pressurised aerosol dispensers, trigger-sprays, powders *inter alia*. A critical factor is how the insecticide is applied by the user. Using an incorrect method of application can decrease the effectiveness (Ogg *et al.*). For example, if a band application is made with a spray product, the insecticide is not delivered in the cracks and crevices. This is important as cockroaches will often be found within inaccessible areas such as cracks and crevices and so failure to deliver the insecticide to these areas may result in treatment failure. For this reason, the extent of the infestation and the cockroach species should be determined before deciding a course of treatment.

2.1.2 Ants

Ants are social insects that form organised colonies in which 3 categories of members (queens, workers, males) assume specialised tasks. Ants are widely encountered with over 15,000 ant species, one of the most important pest species being pharaoh ants.

- Pharaoh ants (*Monomorium pharaonis*)

Pharaoh ants originate from North Africa and Mediterranean and particularly appreciate the interiors of buildings in temperate climate. They live in colonies of some hundreds of individuals including many queens per nest, with workers observed in distinct trails between the nest and food sources. They are often found in cupboards, underneath baths, in jointed walls, under ceramics, technical galleries...*inter alia*. Pharaoh ants are omnivorous and very fond of rotting matter, sweet foods, meat, oil, bread, cake...*inter alia*. Outdoor locations for pharaoh ant colonies include interstices in wood bark, under stones or in wall cracks.

The presence of pharaoh ants causes distress to homeowners because they transport germs and moulds and degrade the food. They can excrete formic acid that has a repulsive odour.

To control ants, various forms of insecticides are available (liquids, solids or gel baits) including baits that contain slow-acting poisons or Juvenile hormone, which sterilize the queens and prevent the larvae from developing into adults. It should be noted that insecticide sprays and dusts are not always 100% effective against pharaoh ants and can make infestations worse by dispersing colonies to new locations (Klotz 2005).

Outdoor control may also be achieved using baits or traps placed on the pathway of pharaoh ants.

- Common Black Ant (*Lasius niger*)

Species such as the common black ant form nests in gardens, under paving stones, in foundations or occasionally within buildings. Each nest contains one queen with the workers foraging on a wide range of foods including sweet substances, seeds and insects. This species have also been known to grow aphids in order to collect honeydew. Nests may survive for many years but young queens leaving the nest as 'flying ants' start new ones each year.

Common black ants are useful species in gardens and outdoor environment where they act as detritivores.

2.1.3 Fleas

Adult fleas are small, wingless insects that feed on the blood of animals and humans. About 2,500 species are described; the most representative indoor fleas are human fleas, cat fleas and the dog fleas. The fleas depend strongly on their host species. If necessary, many species of flea are able to parasitize a range of hosts.

As an example the most common flea species in the UK that comes into contact with humans is the cat flea, which despite the name is also commonly found on dogs. The adult cat flea spends a proportion of its time off the host, resting in the hosts sleeping and bedding areas. The larvae of most flea species feed in and around the bedding areas on dust, debris, flakes of skin and fur and dead insects. They arrive on domestic pets, clothing and sometimes by parcel post. Flea body parts and faeces can contaminate human food. Flea bites are responsible for skin inflammations and could be responsible for the transmission of pathogens (rat fleas: plague at London in 1665; rodent fleas: murine typhus) (Prisse 2002). Control of flea infestations is achieved by various insecticidal treatments of both the host(s) and the flea resting places around bedding, pet's baskets, carpets, sofas and chairs.

2.1.4 Flies

In the home, the most representative fly is *Musca domestica* commonly known as the housefly. The housefly is distributed worldwide and is found wherever suitable breeding conditions exist - such as rotting, fermenting or moist organic matter of a high protein content. Their preferred habitats are buildings, municipal waste, septic tanks and waste water tunnels, although sites such as poultry houses and pig farms can provide them with almost perfect breeding conditions throughout the year.

Flies are vectors of enteric diseases such as dysentery, cholera, typhoid fever, gastro enteritis and tuberculosis. They pick up these diseases when in contact with moulds or rotting matter and transfer infection to humans when they land upon food. They can feed on a range of liquid food, which they suck up or can liquefy solid food with regurgitated digestive fluids from their stomach. Contamination of human foodstuffs can occur from drops of digestive fluid deposited during feeding and *via* faeces which houseflies almost continually deposit.

Chemical control of adult houseflies can be achieved using knock-down or residual insecticidal space sprays or solid baits. The perfect breeding conditions provided by intensive pig and poultry units increases the ability of house fly populations to develop resistance to a range of insecticides. In these situations, the continual use of most standard residual products (particularly residual pyrethroids) should be avoided.

2.1.5 Mosquitoes

Adult females feed on the blood of humans and other animals. They generally live in quiet areas that are humid and where there is no draught and the females lay single eggs onto the surface of a body of water. Many species can cause irritation and/or infection at site of the puncture wound. Furthermore some mosquito species act as vectors for pathogenic bacteria and viruses and are responsible for the transmission of malaria, yellow fever, Dengue fever and encephalitis. Over the world 500 million people suffer from malaria and 1 to 3 million die each year from this disease. Considering the number of deaths attributed to mosquito causes, it is considered one of the most dangerous animals in the world.

Uses of insecticides specific of vector control include:

- *Outdoor large scale spraying.* Treatment of natural water bodies to control mosquito larvae may be operated on large scale by fixed-wing aircraft or helicopters. No scenario will be developed in this document for such application as scenarios, that can easily be adapted, are already available (e.g. AgDrift (Teske *et al.* 2002)...).

Depending on the structure of the landscape, mosquito control may also be performed from the edge of a water body, using standard truck-mounted mosquito abatement equipment. The development of mosquito larvae can also occur in storm water treatment devices. In California, mosquito larvicides are applied using hand-held equipment at small sites and with backpack or truck-mounted high-pressure sprayers at large sites (Metzger 2004). The effective swath width of most backpack or truck-mounted larvicide sprayers is approximately 6 m on a windless day.

As the product directly enters the water compartment, further scenario development is needed in order to assess the risk. In the meantime, scenarios available for the exposure assessment of plant protection products for crops grown in water (e.g. rice) can be adapted and used for this application.

Treatments of the air compartment, in order to eradicate the adult forms are not considered as routine treatment. The use of insecticide sprays or outdoor foggers for control of adult mosquitoes may only provide a temporary reduction of the adult population and should be restricted to situations where the protection of human health is required.

- *Mosquito nets treatments.* The untreated mosquito nets have a mechanical protection against mosquitoes. However they lose their effectiveness when they are misused (the net does not cover all the bed, mosquitoes enter through holes, mosquitoes bite human skin in contact with the netting). In order to avoid these disadvantages, mosquito nets are treated with insecticides (Coosemans *et al.* 1999; WHOPEs 2006). All types of bed nets are treatable, including old nets with holes or nets built with synthetic or natural fibers (Rozendaal 1997).

It has been decided within the expert group on ESDs for insecticides to exclude from the scope of this scenario all the insecticide treatments for vector control.

2.1.6 Wasps/hornets

The different species of wasps belong to the *Vespula* genus. Wasp nests are localised in soil and tree cavities, inside buildings or attached to trees. Hornets (*Vespa crabro*) are the biggest of the *Vespula* genus. Wasps are nuisance pests although they are more serious if in close proximity to buildings. They are feared for their ability to sting, which is painful although rarely lethal unless the sting is on a sensitive area (such as the throat), the subject is allergic to the venom, or the subject is stung a number of times.

When necessary, control is usually achieved by locating the nest and applying a high-volume emulsifiable concentrate or wettable powder spray *via* a long lance to the entrance sites. Self-pressurised aerosol products that deliver a jet-type spray are also available for consumer use for the eradication of wasp nests.

2.1.7 Spiders

Spiders are not insects but are members of the arachnid group. They are carnivorous with some species making webs while others attack their prey. They are considered as beneficial because they prey on nuisance insects. Most spider species are harmless; however there are species that are harmful to humans (e.g. Black Widow, Corn Widow). They can potentially induce allergies following repeated exposure to body fragments and faeces. As explained for cockroaches, spiders cause distress by their presence and webs. A room with cobwebs is associated with a dirty room. Spiders are found in almost any environment both indoors and outdoors including storage areas like basements, garages and cellars. In the very rare circumstances where control is considered necessary, pyrethroid-based insecticidal sprays can be used.

According to the survey conducted during the preparation of the scenario, the outdoor control of spider is mostly performed by spray application. The use of “tracking powder” for spider control is also foreseen.

2.1.8 Dust mites

Dust mites are not insects but are more closely related to spiders (Arachnida). There are two common dust mites, the American house dust mite (*Dermatophagoides farinae*) and the European house dust mite (*D. pteronyssinus*). They live in the fine layer of dust particles and debris that are present in the household and other dwellings. They are found globally but their numbers are considerably reduced at higher altitudes and in dry climates. They are deposited amongst the fibers of mattresses, blankets and sometimes carpets, and feed on moulds present on human skin scales (which make up the bulk of household dust). House dust mites are well known to be associated with allergies. They do not bite or sting but harbour strong allergens in their bodies as well as in their secretions, excreta and shed skins. Constant contact with these allergens can trigger respiratory and dermatological complaints in sensitised human individuals. Dust mites prefer high humidity levels together with warm temperatures. Under these conditions dust mite populations explode. Complete control is difficult and requires a combination of strict cleaning, reduction of humidity and the use of acaricides.

2.1.9 Bed bugs

The common name “bed bugs” usually relates to the insect family Cimicidae (*Cimex lectularius* L.). They are relatively small - approximately 5 mm in length and 3 mm wide. They are nocturnal insects that feed only on blood. They develop by gradual metamorphosis. They live in loose groups in response to a pheromone. They prefer to occupy close locations to their host and will quickly establish themselves in cracks, crevices, headboards, bed frames, mattresses, behind wall-mounted picture and other furniture. In addition rough and dark surfaces appear to be preferred for establishing their harbourage. Wood and paper surfaces are preferred to stone or metal surfaces. In a suitable environment, the females deposit small eggs using a cement-like material onto surfaces in the crevices where they hide. They bite at the frequency of once a day during the nymphal developmental period. The life cycle (eggs to eggs) takes four to five weeks. It is commonly reported that the bed bugs become inactive at temperature lower than 16°C.

Industries that are marketing furniture or bedding should carefully inspect any used or leased items before they are brought into a building (e.g. hotel). If bed bugs are identified, the item should not be introduced into the building. The distributor of the item should be notified and the items returned. Another alternative is to fumigate the infested items prior to introduction into the building.

The recommended control for bed bugs is to spray beds, beddings, mattresses, furniture, wipe the head board and clean any crack. The formulations that are most effective include dust, microencapsulated materials and wettable powders.

2.1.10 Termites

Termites are social insects, living in organized colonies. They live underground, in wood or in nests and move in passageways that protect them from sunlight, air current and excessive moisture loss. The termites that live in darkness are blind.

Termite colonies contain distinct types of castes that differ in both form and function. The three caste categories are the reproducers, the workers and the soldiers. Termites are not pre-destined at birth to become a member of a particular caste and males and females are produced in equal proportions. The caste determination is related to the needs of the colony (Mallis 2004).

- The *reproducer* caste produces all of the colony offsprings and plays a major role in dispersal and foundation of new colonies.
- The *worker* caste, the larger caste, forages for food for the entire colony. Workers also construct mud tubs, excavate chambers and repair the nest when damaged. The mud is composed of tiny particles of soil, wood or debris cemented together with saliva and faecal matter. The young workers care for the eggs and nymphs while grooming and feeding the others. The older individuals that are stronger and larger construct the nest and forage for food.
- The *soldier* caste defends the colony from any attack by ants or other termites. They are larger in size than workers with a large head and well-developed jaws. They hide in mud and will not be seen unless the wood or the mud tubes are disturbed (Ogg *et al.* 2006).

The termites search for food randomly in the soil and cannot detect wood from appreciable distance because the soil environment does not allow chemical signals to travel very far. Once termites find food, they stop to feed and more termites are sent to the food area. The marginal sources of food are abandoned and can be found again if necessary. If termites come across a physical barrier, like the foundation of a building, they move up keeping in contact with the foundation. If they find a crack greater than 0.4 millimeter, they explore it. If the mud tube is exposed to dry air, they may change direction (Ogg *et al.* 2006). Cellulose, the hard structural component of wood and other plant tissues are the main food source of termites. The importance of damage made by termites is related to the size of the colony, the duration of feeding (seasonal infestation relation to the climate) and the type of termite (some termites cause more damage than the others). To gain access to food materials the termites can damage non-food items such as drywalls and plaster.

A key element of the termiticide treatments is to build a barrier which the termites cannot cross. This barrier is built at ground, wall and wood framework levels. In parallel, baits are used indoor and sometimes outdoor (Bordereau *et al.* 2002). The mode of application is described in section 2.4.4.

Because termites are wood destroying insects but may also damage other materials, some scenarios have been described in the OECD ESD for wood preservatives and others will be introduced in the present document, irrespective of the treated material. Since there are no other reasons for doing so than timing for this decision, the table below summarizes the scenario currently covered by the two ESDs concerning termite's treatments.

Table 2.1-1: Termite treatment: scope of the emission scenario documents

Sub-scenario	ESD for wood preservatives	ESD for Insecticides, acaricides and products to control other arthropods for household and professional uses
Indoor injection (curative & preventive treatment)	Section 6.4.2.4: Not covered because environmental emissions considered negligible	Sub-scenarios covered are: - injection in indoor floor (section 3.4.4) - injection in indoor walls (section 3.4.4)
Outdoor injection (preventive & curative treatment)	Sections 6.4.2.4 / 6.4.2.2: Covered for transmission poles	2.4.4 Not covered
Spraying treatment	Indoor: - not covered Outdoor: treatment of foundation covered	Indoor spraying treatments (section 3.3.1.2) Outdoor spraying treatment (section 4.3)
Outdoor traps	Not covered	Traps: the emissions are considered as negligible

2.2 Exposure route to insecticides for target organisms

2.2.1 By ingestion

In this mode of action, the insecticide molecule enters into the target insect by ingestion (swallowing). Some marketed insecticides are composed of an insecticide and an attractant (e.g. specific pheromone or analogue) molecule (e.g. baits). The targeted insects are attracted to the bait, eat the mixture and die.

2.2.2 By inhalation

This exposure route is exclusively reserved to gas-based products. However, when a liquid product is sprayed, particles that are released could transform them into gas (depending on the vapour pressure, the droplet sizes and the temperature).

In the sprayed room, the adult insects will die following contact with a lethal dose of the sprayed insecticide. For the eggs the mode of toxicity is comparable to toxicity by contact: the eggs will close their stigmas. Then, because of very low particle size (few Å) insecticides can diffuse through the cell wall.

2.2.3 By contact

Most insecticides act by contact (when for example a crawling insect is crossing a powder line). Even in the case of a space spray or self-pressurised aerosol insecticide directed against flying insects, the principle action of the insecticide is by direct contact with the insect. The reason for this is that the average droplet size diameter of the aerosolized insecticide is too large to penetrate the spiracles of the insect for death to occur as a result of inhalation.

2.3 The different forms of insecticides

Some active substances available on the market at the time when this report was compiled are presented in Appendix 1: Some active substance in insecticide formulations of this document.

2.3.1 Gas

The active substance may be in gaseous form at the atmospheric pressure (boiling point under the ambient temperature) or may result from a chemical reaction (e.g. it reacts with the moisture ambient content).

2.3.2 Solids

2.3.2.1 Solids used in smoke generator

The combustion of the formulation (commonly a solid) releases a smoke that contains the active substance.

It looks like an active substance transported by a vapour vector. The smoke could be produced by chemical reaction (for example with the air moisture). The size of the particles (smoke with the active(s) substance(s)) is usually under 10 µm and sometimes under 0.1 µm.

2.3.2.2 Contact Powders and wettable powders

These products consist of a low concentration (generally 0.5 – 2.0% although there are exceptions) of the insecticide mixed with an inert carrier powder. They may also be made up of a finely ground mineral (e.g. silica), which is itself insecticidal *via* a physical abrasive mechanism. Powders are dedicated to crawling insects and can be an effective insecticidal barrier.

Powders act by contact and are applied to horizontal surfaces or in voids. In domestic and food premises they should be applied to inaccessible areas where they are not likely to be removed during cleaning or blown about. On the market, two types of powders could be found:

The first are Tracking Powders, which are fine powders that are dusted over surfaces to detect insects, although these are not insecticides. They should not be applied in wet or damp conditions. Tracking Powders can sometimes be combined with an insecticide. Insects walk across the powder and are poisoned when they ingest the powder during cleaning.

The second known as Wettable Powders are insecticidal and are not soluble in water but water could be used as a vehicle for application. Wettable Powders can be used in wet areas. This kind of powder could be sprayed or applied by painting.

2.3.2.3 Water dispersible granules

The product is usually a solid that totally dissolves in water during the mixing/loading step. This form is more representative of water disinfectant products, but sometimes found in insecticides formulations.

2.3.3 Liquids

Liquid insecticides are available under many forms:

- Emulsifiable liquids:

They are generally dedicated to surface application by spraying, atomization and hot atomization. In general, these products are concentrated and need a mixing/loading step with either water or organic solvent. Water-based emulsion sprays should not be applied around electrical installations nor used on absorbent surfaces such as unpainted bricks, concrete and wood.

- Microencapsulated liquids:

These formulations encapsulate the active ingredient in a plastic polymer coat of polyurea.

This form allows a slow diffusion of the insecticide, and also increases the residual activity. The mean particle diameter of encapsulated insecticides is usually very small (5 – 20 µm).

- Lacquers:

Lacquers are ready to use products that contain a filmogen agent. After application (by painting or spraying), the insecticides diffuse slowly through the film. This kind of product is dedicated to crawling insects. They are particularly residual; and can be washed or wiped frequently and still retain their insecticidal properties.

2.4 Materials and modes of application

Definitions of the most common devices are coming from the manual of development and use of FAO and WHO specifications for pesticides (first edition) (FAO/WHO 2002).

2.4.1 Sprayers

The commercial formulation for professional users is contained in a tank with a propellant. The common aerosol sprayer and the one-shot cartridge can be used to dispense the product. The expansion of the mixture propellant/insecticide forms an aerosol in suspension in air. The size of droplets depends on the characteristics of the atomizer. The common sizes are 1 to 10 µm, 20 µm and sometimes 50 µm. Manual spray applicators or self-pressurised aerosols that contain only a limited volume of formulation (e.g. 400 ml) can be used by the general public or as complementary treatment to that offered by professionals. Larger aerosol generators are available for professionals to treat commercial or industrial scale volumes. Many of them use more highly concentrated formulations to produce especially active mists or fogs.

2.4.1.1 **Aerosol dispenser**

A self-pressurised aerosol dispenser is a hand-held product which disperses (generally by a propellant such as butane) as an aerosol of fine droplets or particles, the insecticide formulation following the actuation of a valve.

Aerosol cartridges include all the “ready to use” generators. These devices use a static process and not airflow. The particle sizes are in the range of 0.1 to 10 µm or 20 µm and sometimes 50 µm. they are used to control crawling and flying insects. Aerosol cartridges are classified in sub-categories:

- One-shot aerosol cartridge

These self-pressurised aerosols (often referred to as “Foggers” or “Fumigators”) are designed to release their entire contents as a fog, in “total release” application and are used for space treatments for the purposes of fumigation and the control of insects in difficult-to-access areas.

- Aerosol Dispenser

The self-pressurised aerosol insecticide is the most common device used in the home to control insects. Such products represent the basic treatment of surfaces (against crawling insects) and rapid space-spray treatment for rooms (against flying insects). For outdoor treatments of wasps or hornet nests, a specialized self-pressurised aerosol sprayer has been developed that utilizes a unique valve system. The unique valve system allows consumers to treat a wasp or hornet nest with a jet of insecticide from a safe distance of 3-4 metres without fear of retaliation from the insects.



Figure 2.4-1: In-can sprayer

2.4.1.2 Manual sprayers

Manual sprayers are usually used for the application of liquid insecticides by delivery of particles onto a surface. This type of delivery system is appropriate for rapid treatment, to apply a solid with a liquid base (very volatile solvent) and to build an insect barrier.



Figure 2.4-2: A trigger sprayer

2.4.1.3 Lever-operated Knapsack sprayer

Horticultural sprayers are used when the quantities to be applied are important. For volumes up to 5 litres the manual sprayer might be used. For volumes over 5 litres a backpack sprayer is used. But for these kinds of sprayers, the safety is not optimal. For aggressive formulations, a safer form is preferred (e.g. lacquer product).



Figure 2.4-3: A knapsack sprayer

2.4.1.4 Compressed sprayers

A compressed sprayer consists of a tank where the formulation is introduced and an air compressor connected. The liquid formula is introduced into an airflow coming from the compressor. This system allows pulverization with strong flow and consistency. The safety recommendations must be followed to use this material. These sprayers should preferentially be used for outdoor applications.



Figure 2.4-4: Compressed sprayers

2.4.2 Gel applicators

Insecticide gels usually contain an insecticide mixed with a food attractant such as a pheromone or synthetic analogue, which is generally very specific of the target species. Gels are applied in the area of the track of crawling insects, *e.g.* cockroaches, ants.

Insecticide gels are usually contained in cartridges and are dispensed using an applicator gun. Generally, these cartridges hold about 30 grams of gel.

Gels may also be contained in sealed systems such as baits stations (see point 2.4.9)

The gels are marketed as a ready-to-use form (including a special gel applicator or in boxes); therefore no mixing/loading step is necessary.



Figure 2.4-5: An applicator gun for gel insecticide

2.4.3 Dusters

These kinds of products are ready to use and then there is no preparation step. According to (Bremmer *et al.* 2006), for the general public, the powder insecticide is generally supplied in a shaker. The preparation consists in removing a membrane seal that covers the hole of the shaker. Also there are powders that are supplied in plastic bags, where the corner has to be cut before use.

For professional users other devices are used: dusters are designed specifically for application of dust formulations. Small dusters are generally either hand cranked rotary pumps, delivering the dust on a continuous airflow or piston activated pumps that produce discrete puffs of air to carry the dust. Powders

could be applied on surfaces and on insect tracks. To maximize the powders effects, it is recommended to keep the product on the treated areas (minimizing therefore the airstream and the cleaning events).

In wet areas, no insecticide could be sprayed and the powders that are not wettable are destroyed by water. For this reason a second type of powder (Wettable Powders) could be used in this kind of area.



Figure 2.4-6: A duster for powder insecticide

2.4.4 Injection

The treatment by injection is dedicated to the control of termites and other wood destroying insects. This type of application is partially covered by the OECD wood preservative scenario in which the professional *in-situ* preventive and curative wood treatments by injection are described. The aim of an insecticide treatment by injection is to build a barrier at the floor (treatment of soil and floor), at the wall and at the wood framework (Bordereau *et al.* 2002). Whatever the materials to be treated, it first has to be drilled before injection with high pressure pumps. After this step, the holes are hermetically closed.

The insecticide injection treatment could be classified in four categories:

- Injection around the building

The preventive treatment can be done before or after the construction. Before the construction, the insecticide is sprayed on the entire surface dedicated to the reception of the structure (emission model is described in the OECD scenario for wood preservatives, (OECD 2003)). If the construction is over, the insecticide is then injected in the soil around the building (Figure 2.4-7). The pest control operator applies insecticide following a parallel line to the wall.

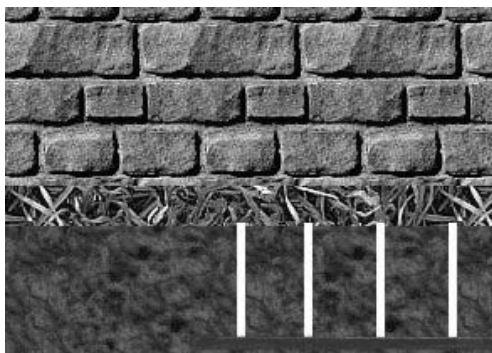

Figure 2.4-7: Insecticide soil injection treatment around the building

- Injection in indoor floor

The ground floor and the crawl space are treated by injection (Figure 2.4-8). (see section 3.3.4).

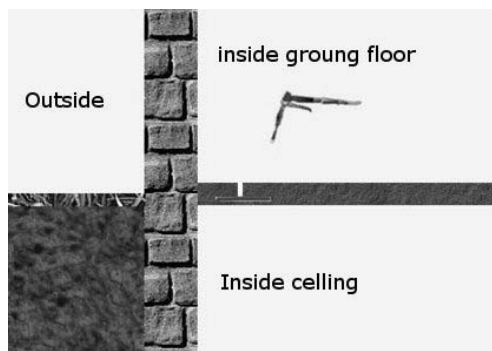

Figure 2.4-8: Insecticide floor treatment by injection

- Injection in indoor (ESD Insecticides, acaricides and products to control other arthropods) and outdoor wall (ESD Wood preservatives)

Inside and outside, in the neighbour of the floor/soil (depending indoor/outdoor), the base of the wall is drilled. After this operation, the pest control operator injects the product through the holes. After the injection, each hole is hermetically closed.

The walls themselves are impassable, only the concrete junctions have to be treated. The cellars and the walls that are under the soil level have their entire surface to be treated.

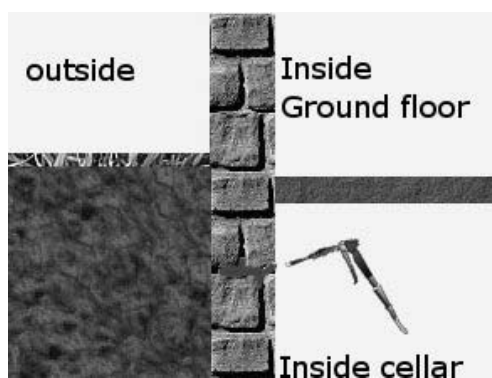

Figure 2.4-9: Insecticide floor treatment by injection

- The last concerns the injection for the treatment of wood (floor, framework).

This application is covered in the OECD Emission scenario document for wood preservatives (OECD 2003).

2.4.5 Gas

Gases are the only insecticides that have a total effectiveness indoors, because they have the unique physical property of being able to diffuse everywhere the pest could hide. This characteristic is connected to the very small size (some Å) of the gas molecules. Gas can diffuse through bricks and concrete. It is stopped by plastic. This product type is only used by qualified professionals.

2.4.6 Smoke generators

The fumigation of infested materials or building structures is a very specialized form of pest control, involving the use of a highly volatile gas having a great power of penetration. The insecticide diffuses homogeneously. Smoke generators are used to treat air volumes to control flying insects and to treat surfaces (by deposition) to control crawling insects. Before use, a particular attention should be paid to the protection outside the building or structure to be treated.

Smoke generators could be used in rooms with furniture, but sometimes it's preferred to move up some equipment. After treatment, a long ventilation period is recommended e.g. 4 to 8 hours in some cases.



Figure 2.4-10: A smoke generator

2.4.7 Diffusers

Diffusers are essentially used by the general public. On the market, several kinds of diffusers could be found. They can be classified in 4 categories:

- The “passive” vaporizers

The passive vaporizers consist of a reservoir of volatile insecticide, which evaporates at ambient temperature. The advantage is that no power source or heat is required (WHOPES 2006); (Rozendaal 1997). Two kinds of treatments are performed depending on the target insects.

- Insecticide dispensers

Active substances used in such devices are usually volatile and their vapours are very toxic to flying insects. The insecticide liquid is impregnated into an absorbent material, such as polyurethane, that allows a slow evaporation without heating (Figure 2.4-11). Before use, they are sealed in an airtight package to avoid premature vaporization of the insecticide.

Most models contain sufficient insecticide to treat a room of 15-30 m³ for 1-2 months (Rozendaal 1997).

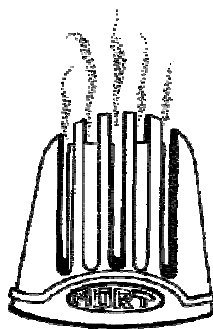

Figure 2.4-11: An insecticide diffuser (WHOPES 2006)

- The diffusers for the treatment of furniture

The principle is the same as those used for the insecticide dispenser. It could be marketed under several forms:

- an impregnated paper that is put in the drawers of furniture.
- a stick pack gel that allows a slow evaporation of the insecticide.

This kind of product is specially designed to control mosquitoes.

- The electric vaporizing mats

This product comprises a mat heater and a mat vapourizer (Figure 2.4-12). The mat is made of cellulose or fiberboard impregnated with insecticide, stabilizers, release-control agents, perfumes and colouring agents. The mats are packed in foil to prevent evaporation of the insecticide before use. The insecticides are usually pyrethroids, which have a rapid killing and repellent effect on flying insects (*e.g.* mosquitoes and biting insects) (WHOPES 2006), (Rozendaal 1997). The mat heater is plugged into an ordinary household electric socket and heated to an optimum temperature of 110-160°C, depending on the type of heater and mat. When the mat is heated, the insecticide is released under a vapour form to provide a low aerial concentration. The advantage of this system is that no smoke is released (WHOPES 2006); (Rozendaal 1997).

For the electrical mat vapourizer, it is necessary to change the mat every day, whereas with the electric liquid vaporizer described below, it's necessary to change the liquid every 1 or 2 months.

The vapour created by the electric device condenses into droplets of around 3.5 µm diameter. The condensed droplets are intermittently generated and they change in diameter (Matoba *et al.* 1994).

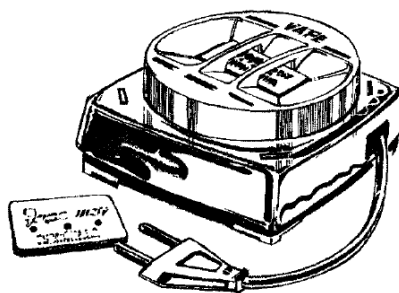

Figure 2.4-12: An example of mat heater (WHOPES 2006)

- The electric liquid vaporizers

The electrical liquid vapourizer principle is the same as that for the electrical mat vapourizer. This device comprises an electric heater and a bottle of insecticide liquid. The liquid, which is a mixture of hydrocarbons and dissolved insecticide(s), is drawn up through a wick by capillary action. The end of the wick is positioned within the heating element so that the insecticide vaporizes from the wick when the heater is activated (WHOPES 2006) (Figure 2.4-13). The liquid insecticide lasts for up to 45 usage periods of 8-10 hours per usage period although this can vary between products. This method is more convenient and more effective than the electrical mat vapourizer because the amount of product released remains constant over the time (Rozendaal 1997)

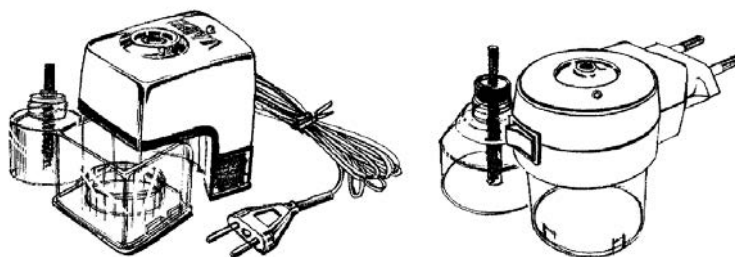

Figure 2.4-13: Examples of electric liquid vaporizers (WHOPES 2006)

- Coils

Coils (Figure 2.4-14) are among the most popular and widely used insecticide vaporizers in Africa, Asia and the Western pacific regions because they are easy to use, inexpensive and frequently claimed as effective (Rozendaal 1997; Krierger *et al.* 2003; WHOPES 2006). Once lit, coils produce sub-micron particles (Chang *et al.* 1998; Krierger *et al.* 2003; Liu *et al.* 2003) and smoulder at a steady rate for 6-8 hours. Originally mosquito coils consisted of a mixture of pyrethrum powder, a combustible filling material and a binder. Some synthetic pyrethroids are now commonly used in coils (Rozendaal 1997). The coils are placed on a suitable stand and the free end is lit. A metal stand is normally provided in a box for coils. The stand ensures that the coils do not touch or rest on a surface, which may cause it to go out or catch fire. When used indoors, coils mounted on stands should be placed on a fireproof base (e.g. plate) (Rozendaal 1997).

If rooms are ventilated or if coils are used outdoors it is important to ensure that the individuals that require protection are upwind of the coil when it is alight and smouldering.

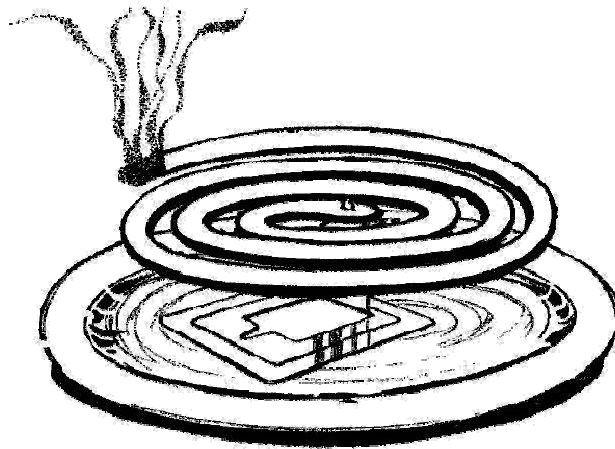

Figure 2.4-14: a mosquito coil placed on a fireproof base (WHOPES 2006)

2.4.8 Foggers

The main purpose of the system is to produce fine insecticide particles suspended in air (5 to 30 μm). This system is dedicated to air space treatments. Two technologies are available.

2.4.8.1 Cold fogging

The formulation is introduced in a variable airflow generated by a turbine. A surface could be treated using this method but only when no other method is available.

For the treatment of a 20 square metres room, the deposition time of insecticide particles is around two hours. The particle sizes are in the range of 5 to 30 μm . The larger particle size enables the droplets to settle faster and therefore prevent drift when used to treat an area outdoors.



Figure 2.4-15: Cold fogging

2.4.8.2 Hot fogging

The principle of use of the hot fogging is the same as for cold fogging, except for the addition of a heating cartridge. The heat increases the rate of volatilization of the fogger liquid. The particle temperature is in the range of 60°C to 80°C. Compared to cold fogging, hot fogging generates smaller particles, which will remain in the air longer. This makes hot foggers more effective for treating insects indoors.

2.4.9 Trap/baits

Traps may have a physical or a chemical effect. Physical traps include glue traps for the control of flying or crawling insects, or high frequency coils for flying insect. The physical effects are often combined with an attractant (UV for high frequency electrifying coils, pheromones for the glue trap) in order to increase the effectiveness of these traps. Physical traps are considered outside the scope of this ESD.

Chemical traps generally consist of insecticide in liquid or solid form coupled with a food attractant (bait) or a pheromone attractant contained in a device often known as a “bait station”. The scope of this scenario does not cover the use of attractants, however since they may also contain insecticides, these modes of application must be considered.

Insecticide/pheromone traps may be found on the market as liquid reservoir containing a volatile formulation of insecticide together with a pheromone diffuser. Flying insects are attracted to the trap by pheromone action and then killed by contact with, or by ingestion of, the insecticide. These traps are usually covered in order to protect the contents from dust and to prevent from unintended access e.g. from children or domestic animals.

Baits usually consist of ready to use products in gel, blocks or granule forms. They always target one species. For highly attractant gels, the quantities applied are around 0.030 g per point. While for the less attractant formulations, approximately 3 g gel could be used per application point. The application rate in a flat is around one point per square metre (Prisse 2002). These insecticide formulations are designed so that the active substance remains in the gel and does not diffuse or leave the bait matrix. They could be used in areas where insecticide could not be sprayed. Baits are generally strong formulations with a good residual life, however, they are less likely to be effective when competing against readily available alternative food sources. Some baits contain a chemical to deter non-target animals from eating them (such as bittering agent), while some products are enclosed within a robust plastic bait station, which protects the bait and discourages ingestion by inquisitive pets.

In bait stations, sometimes improperly called “traps” on the market, insecticide is contained in sealed boxes and placed in the neighbourhood of insect’s tracks. These are usually ready to use products. For these products, emissions to the environment during the treatment are negligible. The only possible emission is when the box is eliminated to waste during indoor uses or through flooding and insect dispersion during outdoor uses.

Baits are also used to control termite infestations. Such treatments are usually performed by professional pest control operators. Baits containing insecticide and a food attractant, such as cellulose are contained in traps. For outdoor applications, traps are buried in soil or may be fixed on the wall on termite pathway. Termites control is considered in the OECD emission scenario document for wood preservatives (OECD 2003).

Termite traps are usually contained in resistant plastic boxes (to prevent access to children and domestic animals) and are fixed on walls or buried in soil on termite pathways by professionals only. Releases to the environment are considered to be minimal during use. At the end of the efficacy period, traps and any remaining product should be collected by Pest Control Operators (PCO) and disposed appropriately. Therefore, no scenario has been derived for termite traps,

2.5 Users/applicators of biocidal insecticides

The results of the survey conducted among OECD countries prior to the drafting of this document indicate that household insecticides and insecticides used in public/commercial/industrial buildings may be applied by the general public, and more generally by non-trained applicators as well as by trained professionals.

Some forms of insecticidal products are specific to the user/applicator: for instance, gels for the treatment of crawling insects are designed for bait stations used by the general public and in a cartridge for “gun application” by professionals. Other forms can be used either by trained or non-trained applicators.

In the same way, the market for general public often comprises ready to use products whereas concentrated forms are only available to professionals. Thus, a mixing/loading step is frequently reserved to professionals, although it is not always the case. Depending on the scenario under consideration, distinct emission calculations are proposed for professional and non-professional applicators, if the use pattern has indicated the need to do so.

2.6 Building type

In view of the outcome of the survey conducted prior to the drafting of the scenario, it appears clearly that insecticides are generally used in or around buildings where the presence of insect pests is unwanted. However, the definition of the typical building is difficult to achieve, since insecticides may be needed in very different situations. Insecticides are applied in private houses but also in public buildings such as hospitals or in professional buildings such as restaurants where the general public is present. Insecticides may also be used to treat large professional facilities such as administrative, municipal or industrial buildings. This ESD was designed in such that the scenarios are representative of as wide a range of applications as possible and can be adapted when needed.

For this purpose, for outdoor application of insecticides, two typical buildings are defined: one small building that would represent the private house (h), and one larger building that could cover public and professional building (p).

- Private houses (h)
 - External dimensions of a typical house

The dimensions retained for the typical private house are those of the emission scenario document for wood preservatives (OECD 2003).

The house is 17.5 metres long and 7.5 metres wide. The treated height of the walls is 2.5 metres (see Figure 2.6-1). It has been noticed that the value of 2.5 metres may not be appropriate for all kinds of applications. Members of the sub-group on insecticides of the OECD Task Force have agreed however that this value may be kept for default assessment on private house only. Still, different sizes can be applied depending on the types of house (*i.e.* if applying to multi-story buildings), application practice, etc...

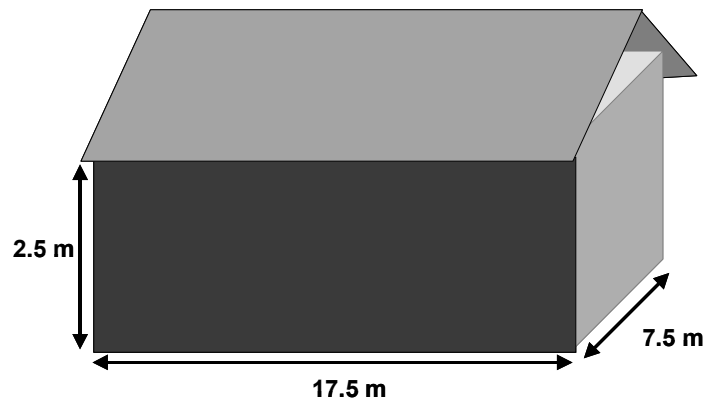

Figure 2.6-1: Dimension of the typical private house

- Sizes of a typical room

According to Consexpo software, default volume for a living room is 58m^3 . Although a unique default value might not be relevant for all types of applications, in this scenario this volume has been chosen as a default value (58 m^3). This value is quite consistent with the value in Expofacts (<http://cem.jrc.it/expofacts/>) where the mean volume of a room in EU countries is around 60m^3 .

For the typical surface of a room, different values have been found.

From the extraction of the Consexpo database (Bremmer *et al.* 2006) and according to the technical note for guidance on human exposure: surface for a room = 22 m^2 . This value will be used in the present document for general spray applications. This value is quite consistent with database of Expofacts, where the mean room area is around 24 m^2 .

In all cases, these values are only proposals for the scenario's user and could be changed at any time.

- Size of the basement

For termite curative/preventive treatments a description of the type of basement is needed. Indeed in regards with the type of construction, the application methods could differ. Typically, two types of basement could be found:

- The cellar:

A cellar is a basement that could be used for the storage of food or drink. This type of basement is more representative of older houses. In this type of basement, the termite treatment is done by injection through the wall of the basement.

- The crawlspace:

A crawlspace is a type of basement in which one cannot stand up. This low space beneath the floor gives worker access to plumbing and wiring. The height is generally around 50 cm, and the surface is generally soil. In this case the termite curative treatment consists of spraying insecticide on the walls, on the soil and on the ceiling.

- Size of the gardens

In addition, default values are also proposed regarding the exterior area.

Data are available for a typical French (UPJ 2005) and German garden (Vosswinkel *et al.* 2003). According to the survey performed by (Vosswinkel *et al.* 2003) in Germany, about 50% of the private house own a garden, with a typical size of 500 m². In this garden, terrace and pathway would represent 6% and 5% of the total surface, respectively.

In the French study (UPJ 2005) conducted on 660 gardens, the 10th percentile is 139 m², the median value is 500 m² and the mean value 750 m². Impermeable areas (without further specification) represent respectively 10 m² (10th percentile) and 78 m² (median) (*i.e.* about 2 and 10 % of the total surface).

Based on these studies, it is proposed to use as default value the 10th percentile for the size of the garden (groundwater assessment) rounded to 140 m², the median value of 500 m² for the size of garden (secondary poisoning, see section Chapter 5) per building and 30 m² for the size of the terrace (*e.g.* for spot application, see section 4.3.4).

The aim of this document is not, however, to provide models for the assessment of groundwater exposure. These are available in national regulation scheme. For European assessment, groundwater concentrations as a 1st Tier approach can be calculated using equation from the EU Technical Guidance Document for porewater (E.C. 2003). In a refined exposure assessment, other models such as of FOCUS ground water, PEARL or PELMO used in plant protect product area can be applied. In this situation, it is recommended that the application rate calculation is based on the 10th percentile for the size of the garden rounded to 140 m².

- Larger buildings (p)

☞ According to the conclusion of the 5th meeting of the Task Force on Biocide, this subsection has to be considered as general information until more relevant data are available to take into account the specificities of the different OECD member countries.

A second type of building, representative of the industrial, commercial constructions and public buildings has to be established. Due to the diversity of the edifices to consider, it is difficult to set a default value. Some structures, such as restaurants may have a size similar to that of the house, whereas others, such as warehouses may be much bigger.

Examples of average UK building size are provided by (HSE 1987) for several building types (Table 2.6-1). However, the average size of such buildings will also depend on national conditions.

Table 2.6-1: Average UK building size (HSE 1987)

Building type	Average building size (UK) m ²
Factories / industrial	978
Offices	319
Shops / restaurants	220
Warehouses / workshop	777
Education	2854
Hospitals	14265
Other Healthcare	658
Public	710
Places of worship	549

Except where the treatment of a specific building is foreseen, it is proposed to use in this scenario a default size of large building being 5 times longer and larger than the private house (L = 87.5 m; l = 37.5 m). The perimeter and the surface of the typical large building are then 250 m and 3280 m², respectively. This size is higher than most of the UK average building sizes except hospitals. This value may be refined if specific applications are foreseen or at national level when local data become available. For treatment dedicated to a specific building type, the data presented in the Table 2.6-1, could be preferentially used.

2.7 *Simultaneity factor*

☞ According to the conclusion of the 5th meeting of the Task Force on Biocide, this section has to be considered as general information until more relevant data are available to take into account the specificity of the different OECD member countries.

In the following scenarios, the use and application of substances (as such or in formulations) is considered at the scale of households or public/commercial building. However, the use of household insecticides has a diffuse character and causes releases to the environment from large numbers of small point sources.

It has to be kept in mind that the use of the insecticides over the year depends on the pest pressure. Besides, during such periods general public and pest control operators use products at the same time.

To take into account this diffuse emission, it will be considered that releases are collected in Sewage Treatment Plant (STP), which will act as a unique point source. Since tonnage values may not be available depending on regulatory context, it is therefore necessary to determine how many houses connected to the STP are simultaneously treated. The following approach is proposed based on the available data: In order to calculate the number of houses connected to the STP, it is proposed to divide its capacity by the number of dwellers per houses.

$$N_{houses} = \frac{CAPACITY_{stp}}{N_{dweller}} \quad (1)$$

Default value for STP capacity is: $CAPACITY_{stp} = 10\ 000$ eq. according to the EU TGD but can be adapted to national specificities. Based on statistical data, the number of people per house ($N_{dweller}$) was estimated around 2.49 (EXPOFACT database available at <http://cem.jrc.it/expofacts/>).

Then it could be assumed that 4,016 houses rounded for further calculations to 4,000 houses are connected to a STP which has a 10,000 equivalent habitant capacity.

Based on a French Survey (CNAM ^e), a default value for the simultaneity of treatment can be proposed:

The French survey is based on 2,281 questionnaires in which the frequency of insecticide uses was asked to the general public.

For the products used to control pest pressure, the frequencies of use are:

- One time per day
- One time per week
- One time per month
- Three to eleven time per year
- One to two times per year

It was considered that if the frequency of treatment is one time per day; 100% of the houses are treated the same day Based on the same reasoning for a weekly use, then the frequency of use on a daily basis is $1/7 = 0.143$ or 14.3%.

The results of this survey are presented in the table below:

Frequency of use	Number of positive answers (%)	% of house treated per day
One time per day	2.77	100
One time per week	9.51	14.3
One time per month	17.74	3.22
Three to eleven time per year	32.15	1.9
One to two times per year	37.82	0.54

Then

$$F_{simultaneity} = \frac{100 \times 2.77 + 14.3 \times 9.51 + 3.22 \times 17.74 + 1.9 \times 32.15 + 0.54 \times 37.82}{100} = 5.52\%$$

^e CNAM: Conservatoire National des Arts et Métiers

As regards insecticides used outdoors such as spray applications around building, none of them is intended to be used daily. Therefore, the simultaneity factor was calculated for outdoor uses without taking into account the frequency of insecticide used on a daily basis.

The simultaneity factor is then: $F_{simultaneity} = 0.0275$ or 2.75%

In the following scenario, local emissions are considered within one day and are expressed as the mass of substance emitted through a unique point source (STP) to environmental compartment per day.

In order to take into account the simultaneity of the treatment, these emission rates have to be multiplied

- by the number of houses connected to the STP: $N_{house} = 4,000$
- and the simultaneity factor $F_{simultaneity} = 0.055$ (indoor) / 0.03 (outdoor)

These emissions rates (i.e. $E_{localair}$ or $E_{localstp}$ expressed in $kg \cdot d^{-1}$) can then be used further in the exposure assessment as input values in atmospheric diffusion models, sewage treatment models or surface water models. These kinds of models are an integral part of all national risk assessment schemes and need not to be mentioned here. Screening models have also been proposed by the OECD (OECD 1992).

Chapter 3 Indoor applications

3.1 Release pathways

This section aims to depict the use pattern of insecticides used indoor. Insecticides applied indoor will generally reach the treated surfaces (furniture, equipments, clothes, walls, floor...), the walls and the floor (even if not directly targeted), the applicator and the indoor air in the building. As a result, insecticides will generally not reach directly the environmental compartments usually considered in emission scenario documents: surface water (including sediments), groundwater, soil and air. Therefore, indoor receiving materials will be considered as “intermediate compartments”. As a matter of fact most surfaces (either target or not) will be cleaned. The cleaning step will therefore lead to releases either to wastes (e.g. through dry cleaning methods like vacuuming) or to waste water (e.g. through wet cleaning methods). Therefore the sewage treatment plants (STP) is considered as one of the main “receiving compartment” where insecticides will be released through wet cleaning events. In Europe, estimates of potential exposures resulting from STPs are carried out according to the standard calculation frameworks presented in the Technical Guidance Document (E.C. 2003). Then, the “final” environmental compartment will logically be the surface water, the groundwater (through STP), the soil (from sludge application) and the outdoor air. As a worst case, it is considered that emissions to indoor air are completely released to the outdoor air compartment during e.g. venting of the room.

The table below shows the main “intermediate” and “final” receiving compartments exposed during the use of insecticidal products in all conditions of uses.

Table 3.1-1 Receiving compartments for insecticide spray uses in indoor

Step	“Intermediate” receiving compartments	“Final” receiving compartments
Mixing loading step	Indoor air Floor Applicator	Outdoor air STP (surface water) (agricultural soil/groundwater)
Application step	Indoor air Floor Applicator Treated surfaces / equipments	Outdoor air STP (surface water) (agricultural soil/groundwater)
Cleaning step	Indoor air Waste water Wastes	Outdoor air STP (surface water) (agricultural soil/groundwater)

3.2 Release estimations for mixing / loading step

Some insecticide products need a preparation step before applying the product. Fractions emitted during this step depend on the form of the commercially available product. It is however not related to the treatment method. The emission factors are named as indicated in the table below. Therefore, the following sections present emission factors that apply to all calculations where mixing / loading step is needed.

Only the number of preparations (N_{prep}) is dependent on the type of application. For this reason, this parameter has been defined for each application type in section 3.3.

The following emission factors also apply to outdoor preparations.

Table 3.2-1 Names of the emissions factors during the mixing/loading step

i	parameter	description
1 - spraying	$F_{prep,air,1}$	Fraction emitted to the air during the mixing/loading step for the application by spraying
	$F_{prep,floor,1}$	Fraction emitted to the floor during the mixing/loading step for the application by spraying
	$F_{prep,applicator,1}$	Fraction emitted to the applicator during the mixing/loading step for the application by spraying
2 - gel	No mixing/loading step for gel	
3 - dusting	$F_{prep,air,3}$	Fraction emitted to the air during the loading step for the application by dusting
	$F_{prep,floor,3}$	Fraction emitted to the floor during the loading step for the application by dusting
	$F_{prep,applicator,3}$	Fraction emitted to the applicator during the loading step for the application by dusting
4 - injection	$F_{prep,air,4}$	Fraction emitted to the air during the mixing/loading step for the application by injection
	$F_{prep,floor,4}$	Fraction emitted to the floor during the mixing/loading step for the application by injection
	$F_{prep,applicator,4}$	Fraction emitted to the applicator during the mixing/loading step for the application by injection
5 - fumigants	No mixing/loading step	
6 - diffusers	No mixing/loading step	

In the literature, no information was available concerning the emissions to the various intermediate compartments identified above (applicator, indoor air, treated surfaces and floor) with regards to the biocide forms and the application modes. To derive such factors, it was chosen to extrapolate them from human exposure values in existing exposure models when available. Based on these values and on the description of the model (surface or volume treated, quantity of product applied...), emission factors were derived.

The hypothesis for final estimation of releases into the environment was that the product emitted to the intermediate compartments (applicator, treated surfaces and floor) ended to the waste water or to the municipal waste as a result of the final cleaning process, whereas emission to indoor air was completely released to outdoor air.

- Emission to air: $F_{prep, air, i}$

As explained above, as far as possible emission factors are derived from existing values related to human exposure models for comparative situations. For example, emissions to air during the mixing/loading step can be compared to data used for human inhalation exposure during the mixing loading step. Whether the model was developed for plant protection products, biocides or other chemical is not very important. The main point is the similarity of the type of products (e.g. liquids, sprays...), the comparable conditions for handling it (e.g. size of the container) and the level of validation of this model (or default parameters). In addition well-known models already recommended in existing EU guidance documents are preferred but other non-European models might be used if data are shown to be representatives of the objectives of the calculation.

- Liquids

According to the TNsG on human exposure to biocidal products,(E.C. 2002), p 135, the 90th percentile value for the exposure by inhalation for loading around 50 kg of concentrated liquid (density about 1.0 g/ml) is 0.02 mg/hour for professionals. Besides, another model by TNO (E.C. 2002) has derived percentile values for the inhalation exposure for loading agricultural pesticides from 0.005 mg/kg a.s. (75th percentile value for machine reservoir) to 0.1 mg/kg a.s. (95th percentile value for portable reservoir). These data show that quantity of product absorbed during the preparation step is very low. In addition, the exposure duration during the mixing/loading is quite brief in comparison with exposure during application.

Therefore, it is suggested to consider the fraction emitted to air during the mixing/loading step to be negligible unless more specific data are available:

$$\rightarrow \text{For liquids: } F_{prep, air, i} = 0$$

- Solids

In the literature, very few data are available for this parameter. The proposed value is derived from human exposure data available in the Pesticide Handler Exposure Database (PHED) to calculate the operator inhalation exposure during the mixing / loading of powders (Frankin et al. 2004). To use this data to derive an emission factor, some hypotheses are needed. The first hypothesis is that the data presented for the PHED model are applicable for a single preparation step. The second hypothesis is that the quantity absorbed by the applicator is similar to the quantity emitted to the air.

During the mixing / loading of 2.5 kg a.s., the exposure by inhalation is 2.4 mg a.s. Then the fraction emitted to air is $2.5 * 10^3 / 2.4 * 10^{-3} = 9.6 * 10^{-7}$.

Therefore from an environmental point of view the emissions to air are negligible and the default value for this parameter is set to 0.

$$\rightarrow \text{For solids } F_{prep, air, i} = 0$$

- Emission to the applicator: $F_{prep, applicator, i}$

The exposure of the applicator can be derived from data available for occupational health exposure models. The exposure, expressed as mg a.s./kg a.s. per operation depends on the form of the product (powder / liquid) and on the device (portable or machine reservoir). The following values derived from a German model for professionals at work when pouring from container into receiving vessel (E.C. 2002) could be used as default values:

- Liquids:
the 90th percentile value for potential dermal exposure is 1195 mg.kg⁻¹a.s.

$$\rightarrow F_{prep, applicator, i} = 1.195 \times 10^{-3} = 0.12 \%$$

- Powders:
the 50th percentile value for potential dermal exposure is 50 mg.kg⁻¹a.s. (90th percentile value is not available)

$$\rightarrow F_{prep, applicator, i} = 0.05 \times 10^{-3} = 0.005 \%$$

- Granules:
the 90th percentile value for potential dermal exposure is 122 mg.kg⁻¹a.s.

$$\rightarrow F_{prep, applicator, i} = 0.122 \times 10^{-3} = 0.012 \%$$

It has been considered by the expert group on insecticides that emissions to the applicators below 0.1% could be considered as negligible for the purpose of this ESD. Therefore, the following default values are suggested.

Table 3.2-2: Emission factor to the applicator during the mixing loading step

Emissions factors	Values
$F_{prep, applicator, i}$ (liquids)	0.0012
$F_{prep, applicator, i}$ (powders)	Lower than 0.001 → negligible: 0
$F_{prep, applicator, i}$ (granules)	Lower than 0.001 → negligible: 0

- Emission to the floor: $F_{prep, floor, i}$
 - Liquids

In the models of the TNGh, emissions are targeted to the hands of the applicator. No data were available for losses to floor during the mixing loading step. Nevertheless, the hypothesis that all products released during the mixing / loading step go to floor seems reasonable (Biocides_Steering_Group 1998). In addition a safety factor of 10 is applied for professional users and a safety factor of 100 for general public users.

Emissions to floor during the mixing / loading step depend on the type of container (volume and design). The following values derived from an English model for professionals at work when pouring fluids from container into receiving vessel (E.C. 2002) can be used as default values.

- For containers with unspecified design the following emission factors could be used:

Table 3.2-3: Emission factors to floor expressed as ml of commercial product per operation for containers with unspecific design (PSD 1992).

Container volume	Losses to the hands	Losses to the floor		$F_{prep, floor, i}$	
		Professional	General public user	Professional	General public user
1 liter	0.01 ml	0.1 ml	1 ml	10^{-4}	10^{-3}
5 litres	0.2 ml	2 ml	20 ml	$4 \cdot 10^{-4}$	$4 \cdot 10^{-3}$
10 litres	0.5 ml	5 ml	50 ml	$5 \cdot 10^{-4}$	$5 \cdot 10^{-3}$
20 litres	0.5 ml	5 ml	50 ml	$2.5 \cdot 10^{-4}$	$2.5 \cdot 10^{-3}$

- For wide-necked containers:

Table 3.2-4: Emission factors to floor expressed as ml of commercial product per operation for wide-necked container (PSD 1992)

Container volume	Losses to the hands	Losses to the floor		$F_{prep, floor, i}$	
		Professional	General public user	Professional	General public user
1 liter D* = all	0.01 ml	0.1 ml	1 ml	10^{-4}	10^{-3}
2 litres D = all	0.01 ml	0.1 ml	1 ml	$5 \cdot 10^{-5}$	$5 \cdot 10^{-4}$
5 litres D = 45/63 mm	0.01 ml	0.1 ml	1 ml	$2 \cdot 10^{-5}$	$2 \cdot 10^{-4}$
10 litres D=45 mm	0.1 ml	1 ml	10 ml	10^{-4}	10^{-3}
10 litres D=63 mm	0.05 ml	0.5 ml	5 ml	$5 \cdot 10^{-5}$	$5 \cdot 10^{-4}$

*D = neck diameter

The UK POEM model describes the exposure to the operators' hands when the in-use product is poured from the container into a receiving vessel. In the present scenario, it has been proposed to derive emissions to floor from the exposure data of this model during the mixing/loading step. Also, for commercial containers that have a volume below 1 litre, it is proposed to use the same value as the one proposed for the one litre container.

- Solids

$$F_{prep, floor, i}$$

In the literature, no information was available concerning the quantity of solid product (e.g. powders) lost on the floor during the preparation step. Moreover products like powders are subject to airstreams. Therefore as a first approach, it is proposed to use 0.01 as default value for the fraction emitted to the floor during the mixing loading step.

3.3 Releases estimations for indoor applications

3.3.1 Spray application (1)

In this document we have considered that aerosol sprayers and manual sprayers can be used by general public (domestic houses) whereas lever-operated knapsack sprayers and compressed sprayer are designed to professional treatments of larger areas. For each type of applicator, different default values have been issued.

3.3.1.1 **Mixing/loading**

Commercially available products used for spray applications are placed on the market in a form (e.g. concentrate) that may need further preparation before application. Two operations are usually considered: the mixing of the concentrate formulation with an appropriate solvent and the loading of the application device. In most occasions, the mixing is performed directly in the sprayer. These steps are considered jointly.

During the mixing / loading step, releases to the environment may occur. For indoor applications, it is assumed that the preparation is always carried-out indoor. The number of preparations per day and the emission factors to all possible environmental compartments have to be considered in order to assess the potential exposure to the environment.

$N_{prep, building, 1}$: Number of preparations per day per building (d^{-1})

The number of preparations is a function of the size of the buildings. For private, houses, it is assumed that one preparation is sufficient whether performed by general public or professionals. For larger buildings, which are more likely to be treated by professionals, it is assumed that up to 3 preparations are needed.

Therefore, the following default factors are suggested to take into account the number of preparations per day:

- For the non-professional use, according to the TNsG on Human exposure to biocidal products, “TNGh”, (E.C. 2002) for dilution of concentrates, a “single event to produce 5 litres of in-use product” may be assumed (E.C. 2002).

$$\rightarrow N_{prep, building, 1} = 1 \text{ for private houses } (d^{-1})$$

- For professional use, we propose to use 1 preparation per day for the professionals that apply insecticide product in household environment and 3 preparations per day for the professionals that apply insecticide in “larger building” (see § 2.6).

$$\rightarrow N_{prep, building, 1} = 1 (d^{-1}) \text{ for private houses; } 3 (d^{-1}) \text{ for larger buildings}$$

3.3.1.2 Spray application

Number of applications per day per building, $N_{appl, building,1}$, (d^{-1})

For non-professional uses, the number of applications per day ($N_{appl, building,1}$) could be derived from the data available in the TNsG on human exposure to biocidal products (E.C. 2002). Besides, values are suggested for estimating the height at which particles are released (this information will be used later in the scenario).

- Air – space aerosol spray indoor: 4 uses daily, 6 s discharged per event,
- Air – space trigger spray indoor: 4 uses daily, 6 s discharged per event,
- Air space treatment, released at 180 cm height,
- Surface aerosol spray indoors: 1 use per week,
- Surface trigger spray indoors: 1 use per week
- Spot treatment releases at 100 cm height
- Crack and crevice treatment released at 25 cm height
- General band/blanket treatment 75 cm height.

In conclusion, for non-professional uses, unless actual data are available, the default value for N_{appl} will depend on the type of spray (4 for volume sprays, 1 for surface sprays).

For professional uses, the number of applications per day is directly related to the mode of application. According to the Technical note for guidance on human exposure to biocides, the median duration using “pesticide” is 120 minutes and the use duration of a self pressurised aerosol dispenser is 6 seconds. Accordingly, the number of applications per day is around 1,000 that is unrealistic. One of the reasons for this inadequate calculation could be that pest control operators use very few self-pressurised aerosol dispensers. They use preferentially pressured sprayers, atomizers, foggers... With these types of devices the number of applications per day is very variable. It may explain why this parameter (number of applications per day, for a professional) has been set to a data requirement in this scenario.

Size of surfaces and volumes to be treated

For household:

- $VOLUME_{treated,1}$

The usual practice for air space applications is to treat the entire house, which covers various sizes of rooms. According to Expofacts (<http://www.ktl.fi/expofacts/>) the mean volume of a room in EU countries is around $60m^3$. This value is quite consistent with the value in Consexpo software: default volume for a room = $58m^3$, corresponding to the volume of e.g. a living room. This figure is chosen as a default value ($58 m^3$).

This value might not be representative of actual situation and should be considered only as proposal for the scenario user and can be changed at any time (see section 2.6).

- $AREA_{treated,1}$

Different values have been found. From the extraction of the database of Expofacts, the mean room area is around 24 m².

This value is quite consistent with the value in (Bremmer *et al.* 2006), in Consexpo and in the EU technical note for guidance on human exposure: surface for a room = 22 m². This later value will be used in the present document for general spray applications.

For general surface treatment: $AREA_{treated,1} = 22 \text{ m}^2$

For targeted spot applications the treatment can take place anywhere in the house. In addition, there is no relationship between the room size and the quantity of product applied. The product sprayed ends up on the object and on the floor around it. A default value of 2m² was suggested (Bremmer *et al.* 2006).

For targeted spot application $AREA_{treated,1} = 2\text{m}^2$

☞ According to the conclusion of the 5th meeting of the Task Force on Biocide, this proposal default value has to be considered as general information

Except where the treatment of a specific building is foreseen, it is proposed to use in this scenario a default size of 3,280 m² (see section 2.6). This value may be refined if specific applications are foreseen or at national level when local data become available. For treatment dedicated to one specific building type, the data presented in Table 2.6-1, should be used preferentially.

For larger building treatment: $AREA_{treated,1} = 3,280\text{m}^2$

Emission factors

All releases to the different compartments will be considered. However, the different emission factors are linked all together in the following equation:

$$F_{applicator} + F_{air} + F_{floor} + F_{treated\ surface} = 1$$

- Emission to air: $F_{application, air,1}$

For the emissions to air during the application step, a value of 2% is already used in the emission scenario document for insecticides for stables and manure storage systems. Therefore, the same value will be used in this scenario for all applications by spraying.

For all applications by spraying (termites included) $F_{application, air,1} = 0.02$

- Emission to the applicator: $F_{application, applicator,1}$

For the emissions to the applicator several values can be derived depending on the treatment type (air space or surface) and on the device used. The exposure values have been extracted from the technical note for guidance on human exposure.

The different emission factors to the applicator related to the application mode are summarized in the table below. The detailed calculations are presented in Appendix 2.

Table 3.3-1: Review of the different emission factors to the applicator with regards to the kind of treatment and the type of spray used

Type of treatment/sprayer	$F_{application, applicator,1}$
Self-pressurised aerosol dispenser (air space treatment)	0.012
Self-pressurised aerosol dispenser (surface treatment)	0.004
Hand-held trigger spray (air space treatment)	0.024
Hand-held trigger spray (surface treatment)	0.006
Compressed sprayer 1 to 3 bars	0.0023
Compressed sprayer 4 to 7 bars	0.018

In this emission scenario document, we propose to set the fraction emitted to the applicator during the application step to 0.02. This value covers the emission factors derived for all types of treatments. In the case where the insecticide product is dedicated to a unique mode of application, specific emission factors related to this mode of application should be used.

$$F_{application, applicator,1} = 0.02$$

- Emission to floor: $F_{application, floor,1}$

The time for the droplets to fall onto the floor depends on their gravity. Therefore, the size of the droplets will be the main parameter for the determination of the emission to floor. According to (Biocides_Steering_Group 1998), the size of the droplets emitted from a ready to use aerosol sprayer is ranging from 1 to 50 μm .

For all sizes of droplets that could be produced by an aerosol sprayer, the falling time is under 24 hours (from 2.5 m height) see Appendix 3.

- For air-space application

In case of air-space treatment, there is no direct application on materials, neither is the air itself “treated”. The aim of this application mode is to build an insecticide aerosol. Air being the support of the treatment, then $F_{application, treated,1}$ is set to 0. The insecticide particles are suspended in the air. They fall on the floor at the day scale. It is the reason why, in this document the fraction emitted to materials is set to 0. The aerosol form favours the insecticide conversion from liquid to gas. Therefore it is proposed for all the

applications by spraying to use a default value of 0.02 for the emissions to air during the application step, the same value as for $F_{application, applicator,1}$ defined above.

In conclusion:

$$F_{application, treated,1} = 0$$

$$F_{application, air,1} = 0.02$$

The sum of the fractions emitted to the different compartments is 1. Therefore during this step, the fraction emitted to the floor could be derived with the following calculation:

$$F_{application, floor,1} = 1 - (F_{application, air,1} + F_{application, applicator,1})$$

$$F_{application, floor,1} = 1 - (0.02 + F_{application, applicator,1})$$

The table below presents the calculated emission factors with regards to the device used.

Table 3.3-2: Emission factors to floor for air-space applications depending on the device used

Type of treatment/sprayer	Emission factor to floor
Air space treatment with trigger spray	$1-(0.02+0.024) = 0.956$
Air space treatment with an aerosol dispenser	$1-(0.02+0.012) = 0.968$
Compressed sprayer (1-3bars)	$1-(0.02 + 0.0023) = 0.978$
Compressed sprayer (4-7bars)	$1-(0.02 + 0.018) = 0.962$

The values presented above show that the emissions to floor are quite similar and do not depend that much on the devices. Therefore in order to simplify the calculations it is suggested to use 0.96 as a default value.

For air-space application $F_{application, floor,1} = 0.96$

For air-space applications, the user could use the aerosol dispenser or the trigger spray. For the other devices, default values are proposed in the Table 3.3-2.

Treatment of surfaces

There is no difference between the floor and the treated area (because they are cleaned with the same method).

With the same reasoning as the one used for air space treatment, some default values have been derived. When an insecticide is sprayed on a surface, an airborne fraction is generated. In reference to Consexpo 4.0 software and the EU Technical note for guidance on human exposure to biocides, $F_{application, treated, 1}$ has been set to 0.15. It is assumed that the fraction emitted to air during the spraying could be set to 0.02. Then it is possible to calculate the fraction emitted to the floor with the equation below.

$$F_{application, floor, 1} = 0.15 - (F_{application, air, 1} + F_{application, applicator, 1})$$

Table 3.3-3: Emission factors to floor for the treatment of surfaces depending on the device used

Type of treatment/sprayer	$F_{application, floor, 1}$
Surface treatment of a with trigger spray	$0.15 - (0.02 + 0.006) = 0.124$
Surface treatment with an aerosol dispenser	$0.15 - (0.02 + 0.004) = 0.126$
Compressed sprayer (1 - 3bars)	$0.15 - (0.02 + 0.0023) = 0.128$
Compressed sprayer (4 - 7bars)	$0.15 - (0.02 + 0.018) = 0.112$

As explained previously, if the product is designed for one application method it is preferable to use the default value for this type of application (see Table Table 3.3-33.3-1). However, in the present scenario we propose to use 0.11 as a default value for the fraction emitted to floor during the application step.

$$\text{For treatment of surface } F_{application, floor, 1} = \mathbf{0.11}$$

- Emission to treated materials: $F_{application, treated, 1}$:

$F_{application, treated}$ is the fraction of insecticide applied on the surface or materials to be treated. For air-space treatment, the air is only a support of the transport of the insecticide in the area to be treated. Then for air-space treatment $F_{application, treated}$ is set to 0 as explained above. For the treatment of surfaces and objects, the default emission factors that is derived from the above calculation is set to:

$$F_{treated\ surface} = 1 - (F_{applicator} + F_{air} + F_{Floor})$$

$$F_{treated\ surface} = 1 - (0.02 + 0.02 + 0.11) = 0.85$$

Table 3.3-4: Emission factors to the treated surface depending of the type of treatment

Type of treatment	$F_{application, treated,1}$
Air-space treatment	0
Treatment of surface/object	0.85

In conclusion and to summarize for spray applications, the table below presents the suggested default emission factors for all “intermediate compartments”.

Table 3.3-5: Review of the different emission factors for unspecified mode of spraying

Variable/parameter	Symbol	Unit	Default
Emission factor to the air during the application step by spraying	$F_{application, air,1}$	-	0.02
Emission to the applicator during the application step by spraying	$F_{application, applicator,1}$	-	0.02
Emission factor to the floor during the insecticide air space treatment by spraying	$F_{application, floor,1}$	-	0.96
Emission factor to the floor during the insecticide surface treatment by spraying	$F_{application, floor,1}$	-	0.11
Emission factor to the treated surface during a surface treatment by spraying	$F_{application, tretated,1}$	-	0.85
Emission factor to the treated surface during an airspace treatment by spraying	$F_{application, tretated,1}$	-	0

In the case where the insecticide product is dedicated to a unique mode of application, the specific emission factors in table 3.3-1, Table 3.3-2, Table 3.3-3, related to this mode of application can be used.

3.3.2 Gel application (2)

According to (Prisse 2002), the quantity of product applied per point of gel depends on its attractive power. This parameter is highly dependent on the characteristics of the formulated insecticide. It is the reason why the quantity of product applied per point of gel is a data requirement in this scenario.

3.3.2.1 Parameters

Gels are typically applied in areas that are characterized by high insect infestation. These areas include voids, cracks and crevices, in legs of equipments, along the plumbing and cable runs, in electric boards or even on the ventilation openings. Due to the inaccessible nature of the treatment areas, gel is often applied in situations where applications using sprays cannot be carried out (e.g. institutional kitchens, hospitals, pharmaceutical laboratories and schools). In addition, the nature of the target application areas is such that gel is largely protected from cleaning processes.

Number of applications per day $N_{appl, building, 2}$:

For better efficacy with this kind of product, all the building should be treated at the same time. In household environment, based on expofact database, the mean number of rooms except for the bathroom and the kitchen is 3.55, then the mean number of rooms is 5.55. As a conservative view, this room number is round off six. According to the technical note for guidance on human exposure, the surface for a room is 22 m². The application of gel is then considered as a single application with a surface treated set to 132m².

$N_{appl, building, 2} = 1$ (household environment)

$N_{appl, building, 2} =$ data requirement (larger building)

Number of points of gel per square meter N_{point} :

The recommendations for the applications of these kinds of products are typically given as a number of gel points per area. Gel products are usually applied at a rate of 1-3 spots per square meter, depending on species and severity of infestation in the facility.

For those reasons we can set two default values:

- The first is related to the application either for a preventive treatment or for a curative treatment with a low infestation. In this case, the number of gel points per square meter should be set to 1,
- The second situation assumes curative treatment with a high infestation level. In this case the number of points per square meter should be set to 3.

Emission factors

Due to the form of the product, no emission to air and to applicator is expected. Therefore, all releases are emitted to the treated surface:

- Emission to the treated surface $F_{application, treated, 2} = 1$
- Emission factor to the air $F_{application, air, 2} = 0$
- Emission to the applicator $F_{application, applicator, 2} = 0$

3.3.3 Dusting (3)

Two product types have to be considered. The first one concerns the products that are sold under a ready to use form where no preparation step is needed. This kind of product is more dedicated to general public user.

The second concerns the application by the professional users where a preparation step can occur.

3.3.3.1 **Mixing/loading**

Two major ways are offered to the pest control operators:

For wettable powders that are water compatible, the major way of application is by spraying (see section 3.3.1). The powder is introduced in the tank of a sprayer and mixed with water or with another solvent. For this one, the emissions to the environment are covered in the section on application by spraying.

For tracking powders, for safety, they are destroyed by water. They are only applied with dusters. In this section, the application with ready to use powders (general public) and the application with dusters (general public and especially professionals) are considered. The mixing/loading step consists in introducing the powder insecticide in the duster tank (loading only). During these operations exposure takes place to the operator, to air and to the floor.

Number of preparations per day $N_{prep, building, 3}$:

The following default factors are suggested:

- For the non-professional use, no data were found concerning the mixing/loading step of this kind of product. But as explained before, the products dedicated to non-professionals are ready to use and this step is not necessary. In case were a mixing loading step is needed and according to the TNsG on Human Exposure where a frequency of use is one time per week for cracks and crevices treatment and one time per month for broadcast treatment, it is proposed to use 1 preparation per day for the non professional users.

→ $N_{prep, building, 3} = 1$ for non-professional uses (d^{-1})

- For professional uses, it is proposed to use 1 preparation per day for private uses and 3 preparations for professionals who apply insecticide in “larger building” (see § 2.6).

→ For professional $N_{prep, building, 3} = 1$; (household); 3 (larger buildings)

3.3.3.2 Application step

- Number of applications per day $N_{appl, building,3}$:

According to the TNGh, for a non-professional, the number of applications is one per week for surface dusting crack and crevices treatments and one per month for surface dusting broadcast.

- Size of surfaces to be treated $AREA_{treated,3}$:

Several values could be found in the literature but according to (Bremmer *et al.* 2006) the default value for dust mite control is 22 square meters. Therefore the default value for “general surface treatment” is set to 22 square meters that is consistent with the default value used for the application by spraying in case of wettable powders. This default value is dedicated to the treatments where the entire floor has to be treated (dust mites, flies...)

$$AREA_{treated,3} = 22 \text{ m}^2 \text{ for general surface treatment:}$$

In some cases, this default value is not relevant. For example for social insects, it is not necessary to treat all the floor, the operator has just to apply insecticide on the insect tracks. The powders are effective insecticides for the treatment of cracks and crevices. For these kinds of applications, (Bremmer *et al.* 2006) propose one square meter as a default value. However, to be consistent with the default value proposed for the application by spraying (wetable powders), the value is set to 2 squares meters.

$$AREA_{treated,3} = 2 \text{ m}^2 \text{ for targeted applications:}$$

☞ According to the conclusion of the 5th meeting of the Task Force on Biocide, this proposal default value has to be considered as general information

Except where the treatment of a specific building is foreseen, it is proposed to use in this scenario a default size of 3,280 m² for larger building treatments. This value may be refined if specific applications are foreseen or at national level when local data become available. For treatment dedicated to one specific building type, the data presented in the Table 2.6-1, should be preferentially used.

$$AREA_{treated,3} = 3,280 \text{ m}^2 \text{ for larger building treatment:}$$

Emission factors

All releases to the different compartments will be considered. However, the different emission factors are linked to the following equation:

$$F_{application, air,3} + F_{application, floor,3} + F_{application, treated,3} + F_{application, applicator,3} = 1$$

This paragraph concerns only the powders that are dusted. For the wettable powders that are mainly applied by spraying, the relevant model is this that described for general surface treatment by spraying. All the factors and the defaults values presented below concern only the powders that are applied by “dusting” and not spraying.

- Emission to the treated surface $F_{application, treated,3}$:

According to (Bremmer *et al.* 2006), the airborne fraction generated during the application with a duster is 0.2 g/g. then $F_{application, treated,3} = 0.8$

- Emission factor to the air $F_{application, air,3}$:

At this stage, very few information is available for this parameter. It has been stated that during the application, 20% of the insecticide applied generate an airborne fraction. At the time scale of the day, this suspension is modified. A fraction lands on the floor and another “turns into gas”. For this parameter, in the absence of new data, it is suggested to use the same default value as for the application by spraying. The powder insecticide suspended in the air is an aerosol.

$$F_{application, air,3} = 0.02$$

- Emission to the applicator $F_{application, applicator,3}$:

As explained previously in the document, powders are subject to airstream. In Appendix 4, Table 7.4-1, the calculation of the emissions to the applicator during a powder broadcast treatment is described. In regards with the results and in accordance with the reasoning used for the emission to the applicator during the preparation step, the emission to the applicator could be considered as negligible from an environmental point of view.

$$F_{application, applicator,3} = 0$$

- Emission to the floor $F_{application, floor,3}$:

The emission to the floor can be calculated on the basis of the equation below

$$(F_{application, air,3} + F_{application, floor,3} + F_{application, applicator,3} + F_{application, treated,3} = 1$$

$$\text{Then } F_{application, floor,3} = 1 - (F_{application, air,3} + F_{application, applicator,3} + F_{application, treated,3})$$

$$F_{application, floor,3} = 1 - (0.8 + 0.02) = 0.18$$

$$F_{application, floor,3} = 0.18$$

3.3.4 Injection (4)

3.3.4.1 **Mixing/loading step**

This application mode is dedicated for the treatment of termites and wood destroying insects. To build an insecticide barrier, some drills are made near the concrete expansion joint. From that moment insecticide is injected under pressure in the drill. The quantity of product injected is related to the thickness of the wall. After the treatment the drill are carefully stopped up.

Number of preparation per days $N_{prep, building,4}$:

This application mode is designed for professionals. The quantity of product injected is directly related to the surface of the building and more specifically to the wall length. It is assumed that the pest control operator only prepares the necessary quantity to be applied. The treatment by injection needs a high volume of product. The device used for the treatment is directly related to the quantity to be applied.

In this document, the number of preparations per day is one.

$$N_{prep, building, 4} = 1$$

3.3.4.2 Application step

Number of applications per day $N_{appl, building, 4}$:

As mentioned in the Technical Notes for guidance on human exposure, the application duration is 4 hours (range 1 to 11.5 hours). Before applying insecticide by injection, the application location has to be prepared. The pest control operator has to drill the material to be treated and after the insecticide injection, the holes are hermetically closed. These pre and post steps are time consuming. Then the number of applications per day is set to 1.

$$N_{appl, building, 4} = 1$$

Area/volume to be treated:

For injection treatments, it cannot be considered that a volume or an area is treated. In regards with the location of the application, it is more relevant to relate the quantity to be applied to the length of the wall. In this document it is proposed to use the perimeter of the building as the “size” for the treatment.

As presented before, the default size of a house is 17.5 meters long and 7.5 meters wide. Its perimeter is therefore 50 meters. For the larger buildings these sizes have to be multiplied by 5. Then for larger buildings the perimeter is 250 meters.

☞ According to the conclusion of the 5th meeting of the Task Force on Biocide, this proposal default value for larger buildings has to be considered as general information

$WALL_{length}$: 50 meters for household, and 250 meters for larger buildings.

Emission factors:

- Emission Factor to the air $F_{applicatio n, air, 4}$:

The application by injection does not generate aerosol particles that have an impact to the environment. After 4 hours of application, the Pest control operator is exposed to 5.32 mg a.s. (E.C. 2002) and after the application, the injection holes are hermetically closed.

We propose to set this parameter to 0 unless more specific data are provided.

$$F_{applicatio n, air, 4} = 0$$

- Emission factor to the floor $F_{applicatio n, floor, 4}$:

In the emission scenario document for wood preservatives (OECD 2003), it is mentioned that during injection 5% of product is lost due to dripping. Therefore, it is proposed to use the same value in the present emission scenario.

$$F_{\text{application, floor, 4}} = 0.05$$

- Emission factor to the applicator $F_{\text{application, applicator, 4}}$:

In the Technical Note for Guidance on human exposure to biocides, a model is available to estimate human exposures during the treatment by injection. According to (Cattani *et al.* 2001), the application rate is 100 litres per cubic meter of material to be treated. The median duration of the treatment is 4 hours (1 to 11.5 hours). 20 litres of an active substance at the commercial concentration of 450g.l⁻¹ is introduced in a 200 to 300 litres tank. The concentration of the active substance in the product is 0.5%. It is assumed that the pest control operators prepare only the quantity needed for the application.

To derive emission factors some hypotheses are made: the density of the in use product is considered to be of 1 and its diffusion power is supposed to be constant. The aim of this treatment is to build a barrier. In this example the drill are 30 cm spaced. Then the insecticide has to diffuse through 15 cm of wall (Figure 3.3-1).

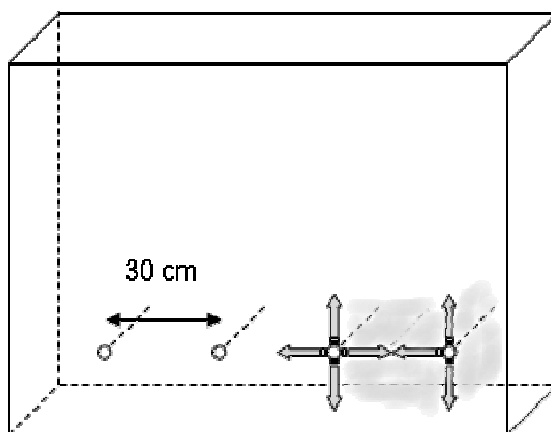

Figure 3.3-1: the wall treatment by injection

The diffusion occurs in all the directions. Then the volume of wall treated per linear meter can be calculated. The treated volume is 30 cm height to 30 cm large and 1 meter long.

$$\text{Volume treated} = 0.3 * 0.3 * 1 = 0.09 \text{ m}^3.$$

Based on an application rate of 100 litres per cubic meter of wall (Cattani *et al.* 2001), the volume of insecticide injected is 9 litres.

On his website, a pest control operator describes the mode of injection of an insecticide: the treatment consists to drill the wall every 20 cm and to inject 1.5 litres per hole. Then the quantity applied is 7.5 litres per meter of wall. This result is consistent with the 9 litres volume of insecticide injected based of the report by (Cattani *et al.* 2001).

Then in order to derive emission factors it is suggested to use the following values:

- 1.5 litres for the volume injected per hole,
- 30 cm for the space between 2 holes.

The default size of the house described in section 2.6 leads to a perimeter of 50 meters. The number of drillings is then: $50/0.3 = 167$ holes and the volume of insecticide injected is $167 * 1.5 = 250$ litres.

Taking into account a loss of 5% of product due to dripping, the volume of insecticide applied is $250 * 1.05 = 262.5$ litres

Using the concentration of the active substance in the in-use product of 0.5% and the hypothesis that the density of the preparation is 1, the mass of active substance used is $262.5 * 0.005 = 1.31$ kg. This figure could be compared to the total amount of active substance to which the operator may be exposed as presented in the following table.

Table 3.3-6: Calculation of the contamination during the insecticide injection (Cattani *et al.* 2001)

	Dermal 75 th	Into gloves 75 th	By inhalation 75 th
Exposure	25.8 mg.min ⁻¹	8 mg.min ⁻¹	0.57 mg.m ³
Duration of the exposure	4 hours	4 hours	The inhalation rate is set to 14m ³ .d ⁻¹ . 240 min # 2.33m ³
calculation	25.8 * 240 = 6.2g	8 * 240 = 1.9g	2.33 * 0.57 = 1.33 mg
Total	8.1 g		

$$\rightarrow F_{application, applicator,4} = \frac{8.1}{1310} = 6 \cdot 10^{-3} \approx 0.01$$

- Emission factor to treated material $F_{applicatio n, treated ,4}$:

the treated material is the wall or the floor to be treated.

$$F_{application, air,4} + F_{application, floor,4} + F_{application, applicator,4} + F_{application, treated,4} = 1$$

$$\text{Then } F_{application, treated,4} = 1 - (F_{application, air,4} + F_{application, floor,4} + F_{application, applicator,4})$$

$$F_{applicatio n, treated ,4} = 0.94$$

3.3.5 Fumigant/gas (5)

Fumigants could be used by general public or professionals in the form of ready to use products. Emissions to the environment have already been described in a previous ESD (van der Poel *et al.* 2002) that used the same model as for the fumigation of buildings and silos. It was considered that such application was similar to the application of fumigants used indoors.

Emissions to the applicator are considered as negligible as the applicator should not be present during fumigation events. As a matter of fact for most devices there is latency between the action and the release of the product in order to give the applicator the time to go out of the room to be treated. Unless the applicator is accidentally exposed emissions to the applicator is then equal to 0: $F_{application, applicator,5} \approx 0$

For such devices, no distinction is made between possible releases to the floor and possible releases to

other treated surfaces and goods. Therefore, a global fraction of substance retained in goods (F_{ret}) is used. In the previous emission scenario document, the fraction of retention in goods was estimated to be of 0.02 as a default value. This will be used in the present scenario: $F_{ret} = 0.02$

Then

$$F_{application, air, 5} + F_{ret} + F_{application, applicator, 5} = 1 \text{ and } F_{application, air, 5} \approx 1 - F_{ret}$$

However, in addition to the retention in goods, a slight disintegration of the substance has to be taken into account in the calculations: $F_{disin} = 0.001$

Finally, it is considered that all releases occur in one day (the duration of the treatment is about a few hours and a long ventilation is recommended after treatment): $T_{emission} = 1$ day.

3.3.6 Diffusers (6)

The diffusers are generally used by general public. They are dedicated to the control of flying insects and they are more often used during the night.

Two types of diffusers are available (Section 2.4.7), the passive diffusers that can't be stopped and the electrical diffusers that can be switch off after use.

This kind of product is ready to use therefore there is no mixing/loading step.

Use duration:

The duration of use per day T_{DAY} :

The use duration for electrical diffusers is often recommended to be the duration of a night. In Consexpo model this duration is set to 8 hours for electrical vaporizers.

The passive vaporizers can not be stopped. Then the duration of the emission is 24 hours.

Therefore, the following default values are considered in this emission scenario:

$$T_{DAY} = 8 \text{ h.d}^{-1} \text{ for electrical vaporizers}$$

$$T_{DAY} = 24 \text{ h.d}^{-1} \text{ for passive vaporizers}$$

Emissions factors:

The insecticide emitted through vaporizer devices is under a vapour form. A fraction could turn in liquid form and land on the floor.

No data could be found in the literature for defining the fractions emitted to air or floor. Nevertheless, as a first approach it is supposed that the emissions occur mainly to air and secondary to the floor.

- Emission to the air:

This parameter has been set to 0.9.

$$F_{applicatio n, air, 6} = 0.9$$

- Emission to the floor:

This parameter has been set to 0.1

$$F_{applicatio n, floor, 6} = 0.1$$

3.3.7 Strategy to take into account the cleaning step for indoor applications

Table 3.3-7: Explanation of symbols

Explanation	Symbol
Fraction emitted to solid wastes by the applicator during the cleaning step	$F_{applicator, w}$
Fraction emitted to waste waters by the applicator during the cleaning step	$F_{applicator, ww}$
Fraction emitted to solid wastes during the cleaning step	F_w
Fraction emitted to waste waters during the cleaning step	F_{ww}
Cleaning efficiency	F_{CE}

Releases to wastes and wastewater during cleaning event depend on the efficiency of the cleaning. The Table 3.3-8 presents some estimates of the fraction of applied insecticide that might be exposed to cleaning (using either wet or dry methods) for a range of different formulation/application types. The values are based on expert judgment and no more precise data could be found in the literature. These estimates are intended to reflect the fact that in many cases insecticides will be applied in areas of greatest insect pressure which, by their very nature, tend to be inaccessible and therefore not exposed to routine cleaning. The potential for exposure to cleaning is dependent not only on the type of formulation but also the specific method or target area of application. As a result, care should be taken to select emission fractions that properly reflect the use pattern and nature of the product being evaluated. The estimations of the fraction of insecticide exposed to cleaning do not take into account the potential degradation and /or sorption onto the different materials exposed.

The definition of dry cleaning methods is assumed to include vacuuming as well as cleaning with disposable clothes. Wet cleaning refers to any method that uses water. It is assumed that residues removed through wet cleaning may potentially be emitted to the wastewater compartment, whilst residues removed through dry cleaning would potentially be emitted to municipal landfill.

This is reflected in the estimates of potential exposure to cleaning for gel formulations presented in Table 3.3-8, which range from 3 % for crack and crevices applications to 25 % for those applied to surfaces. It is assumed that no release will occur during the service life stage for gels deployed in bait stations. These values could be changed when more information is available for specific treatments.

Table 3.3-8: Cleaning efficiency for different products used (CEFIC Insecticides Working Group)

Formulation / Use	Maximum % exposed to cleaning (either wet or dry methods)	Cleaning efficiency
Solid Baits (in bait stations)	0	0
Gel – Bait station	0	0
Gels – Crack and crevice	3	0.03
Gels - Surface	25	0.25
Dust / powders Voids / cavities	0	0
Dust/powders - Surface	50	0.5
Spray – Crack and crevice	25	0.25
Spray - Surface	50	0.5
RTU Aerosols – Space Spray/diffuser	100	1
RTU Aerosol – Crack and crevice (including foams)	3	0.03
RTU Aerosols - Surface	20	0.2

- First case: Releases to solid waste

All the releases are directed to solid wastes during cleaning including those emitted by the applicator (when disposing PPE).

- 100% of the coveralls are disposable,
then $F_{applicator, w} = 1$ and $F_{applicator, ww} = 0$
- 100% of the surfaces are cleaned by vacuum/broom,
then $F_w = 1$ and $F_{ww} = 0$

- Second case: Release to waste water:

All releases are directed to waste water during cleaning including those emitted by the applicator (when washing its PPE)

- 100% of the coveralls are washable,
then $F_{applicator, w} = 0$ and $F_{applicator, ww} = 1$
- 100% of the surfaces are cleaned with water, then $F_{ww} = 1$ and $F_w = 0$

3.4 Emission models for indoor treatments

3.4.1 Application by spraying

3.4.1.1 Mixing/loading

The application by this way concerns two types of products:

- The ready to use products:

The most representative household ready to use product (RTU) is the aerosol cartridge. It could be used for the treatment of surfaces or volumes and for the treatment of crawling and flying insects. Aerosol cartridges are generally used for the local and occasional treatment. It is not relevant to consider the mixing / loading stage for ready to use products.

- The products that need a preparation step:

In most cases products that require mixing/preparation will be applied by professional pest controllers.

One of the issues to consider is the place where this preparation is carried out. For indoor or outdoor application, it is expected that when water is used as a solvent, the preparation of the product will take place in rooms with a source of water. These kinds of rooms usually correspond to rooms cleaned by water. For indoor applications when an organic solvent is used for mixing, it is expected that, due to the risk of spilling, preparation is also carried out in a room that can easily be cleaned by water.

During the preparation step, a fraction of the commercial product is released to air, another fraction may contaminate the applicator and a further portion may be released to the floor.

- Emission to air:

$$E_{prep, air,1} = Q_{prod, prep,1} \times F_{AI} \times N_{prep, building,1} \times F_{prep, air,1} \times 10^{-3} \quad (2)$$

Variable/parameter (units)	Symbol	Unit	Default	S/D/O/P
Input:				
Quantity of commercial product used for the preparation per building.	$Q_{prod, prep,1}$	g	-	S
Fraction of active substance in the commercial product	F_{AI}	-	-	S
Number of preparations per day house larger building	$N_{prep, building,1}$	d ⁻¹	1 3	P
Fraction emitted to air [-]	$F_{prep, air,1}$	-	0 ^f	D
Output:				
Emission to air during preparation step	$E_{prep, air,1}$	kg.d ⁻¹	-	-

^f It is assumed that the fraction emitted to air during the mixing/preparation step is negligible unless more specific data available.

- Emission to applicator:

$$E_{prep, applicator,1} = Q_{prod, prep,1} \times F_{AI} \times N_{prep, building,1} \times F_{prep, applicator,1} \times 10^{-3} \quad (3)$$

Variable/parameter (units)	Symbol	Unit	Default	S/D/O/P
Input:				
Quantity of commercial product used for the preparation per building	$Q_{prod, prep,1}$	g	-	S
Fraction of active substance in the commercial product	F_{AI}	-	-	S
Number of preparations per day house larger building	$N_{prep, building,1}$	d ⁻¹	1 3	P
Fraction emitted to applicator during preparation step Liquid Powders Granules	$F_{prep, applicator,1}$		0.0012 ^g 0 0	P
Output:				
Emission to applicator during preparation step	$E_{prep, applicator,1}$	kg.d ⁻¹	-	-

^g These proposed values are presented in the Table 3.2-2.

- Emission to floor:

$$E_{prep, floor,1} = Q_{prod, prep,1} \times F_{AI} \times N_{prep, building,1} \times F_{prep, floor,1} \times 10^{-3} \quad (4)$$

Variable/parameter (units)	Symbol	Unit	Default	S/D/O/P
Input:				
Quantity of commercial product used for the preparation per building	$Q_{prod, prep,1}$	g	-	S
Fraction of active substance in the commercial product	F_{AI}	-	-	S
Number of preparations per day house larger building	$N_{prep, building,1}$	d ⁻¹	1 3	P
Fraction emitted to floor during preparation step [-]	$F_{prep, floor,1}$	-	Table Table 3.2-33.2-3 & Table 3.2-4	P
Output:				
Emission to floor during preparation step	$E_{prep, floor,1}$	kg.d ⁻¹	-	-

3.4.1.2 Application step

For indoor spray applications, two subcategories can be distinguished:

The insecticides can be used for an air space treatment (for example to control flies or mosquitoes) or they can be applied onto a surface (for example for the treatment of crawling insects).

During the application of the product, four compartments could be concerned:

$$F_{application, air,1} + F_{application, floor,1} + F_{application, treated,1} + F_{application, applicator,1} = 1 \quad (5)$$

Variable/parameter (units)	Symbol	Unit	Default	S/D/O/P
Fraction emitted to air during application	$F_{application, air,1}$	-	0.02	D
Fraction emitted to floor during application <i>Air space application:</i> <i>Surface application</i>	$F_{application, floor,1}$	-	0.96 0.11	P
Fraction emitted to treated surfaces during the application <i>Air space application:</i> <i>Surface application</i>	$F_{application, treated,1}$	-	0 0.85	P
Fraction emitted to applicator during application <i>Air space application:</i> <i>Surface application</i>	$F_{application, applicator,1}$	-	0.02 0.02	P

- Emission to air:
 - Air-space treatment:

For air-space treatment, the insecticide is directly sprayed from the applicator to air:

$$E_{application, air,1} = N_{appl, building,1} \times F_{application, air,1} \times Q_{prod,1} \times F_{AI} \times VOLUME_{treated,1} \quad (6)$$

Variable/parameter (units)	Symbol	Unit	Default	S/D/O/P
Input:				
Number of applications per day per building:	$N_{appl, building,1}$	d^{-1}		
- non-professional				
- professional			4	D
			-	S
Fraction emitted to air during application	$F_{application, air,1}$	-	0.02	D
Quantity of commercial product applied	$Q_{prod,1}$	$kg \cdot m^{-3}$	-	S
Fraction of active substance in the commercial product	F_{AI}	-	-	S
Volume treated with the product	$VOLUME_{treated,1}$	m^3		
- General air space application (household).				
- Larger building				
			-	S
Output:				
Emission to air during application step	$E_{application, air,1}$	$kg \cdot d^{-1}$		

- Treatment of a surface:

$$E_{application, air,1} = N_{appl, building,1} \times F_{application, air,1} \times Q_{prod,1} \times F_{AI} \times AREA_{treated,1} \quad (7)$$

Variable/parameter (units)	Symbol	Unit	Default	S/D/O/P
Input:				
Number of applications per day per building	$N_{appl, building,1}$	d^{-1}		
- non-professional			1	D
- professional			-	S
Fraction emitted to air during application	$F_{application, air,1}$	-	0.02	D
Quantity of commercial applied	$Q_{prod,1}$	$kg \cdot m^{-2}$	-	S
Fraction of active substance in the commercial product	F_{AI}	-	-	S
Area treated with the product	$AREA_{treated,1}$	m^2		P
- target spot application (household)			2	
- general spray application (household)			22	
- Larger building			-	S
Output:				
Emission to air during application step	$E_{application, air,1}$	$kg \cdot d^{-1}$	-	-

- Emission to floor:

When spraying insecticides, particles will fall on the floor at a speed that is dependent on the particle size (see Appendix 2). Nevertheless, it has been demonstrated that all particles above 1 µm diameter will fall on the floor within 1 day (see Table 7.3-1). Therefore, even if the insecticide is sprayed into the air (when the aim of the treatment is to provide an atmosphere with suspended insecticide particles), an important fraction of particles emitted will reach the floor (see Table 3.3-2) and then will be possibly released to the environment through cleaning events (see section 3.5).

- Air space treatment:

$$E_{application, floor,1} = N_{appl, building,1} \times F_{application, floor,1} \times Q_{prod,1} \times F_{AI} \times VOLUME_{treated,1} \quad (8)$$

Variable/parameter (units)	Symbol	Unit	Default	S/D/O/P
Input:				
Number of applications per day per building: - non-professional - professional	$N_{appl, building,1}$	d ⁻¹	4 -	D S
Fraction emitted to Floor during application	$F_{application, floor,1}$	-	0.96	D
Quantity of commercial product applied	$Q_{prod,1}$	kg.m ⁻³	-	S
Fraction of active substance in the commercial product	F_{AI}	-	-	S
Volume treated with the product - General air space application (household). Larger building	$VOLUME_{treated,1}$	m ³	58 -	D S
Output:				
Emission to floor during application step	$E_{application, floor,1}$	kg.d ⁻¹	-	-

- Treatment of a surface:

$$E_{application, floor,1} = N_{appl, building,1} \times F_{application, floor,1} \times Q_{prod,1} \times F_{AI} \times AREA_{treated,1} \quad (9)$$

Variable/parameter (units)	Symbol	Unit	Default	S/D/O/P
Input:				
Number of applications per day per building - non-professional - professional	$N_{appl, building,1}$	d ⁻¹	1 -	D S
Fraction emitted to Floor during application	$F_{application, floor,1}$	-	0.11	D
Quantity of commercial product applied	$Q_{prod,1}$	kg.m ⁻²	-	S
Fraction of active substance in the commercial product	F_{AI}	-	-	S
Area treated with the product - target spot application (household) - general spray application (household) - Larger building	$AREA_{treated,1}$	m ²	2 22 -	P S
Output:				
Emission to floor during application step	$E_{application, floor,1}$	kg.d ⁻¹	-	-

- Emission to applicator:
 - Air-space treatment

$$E_{application, applicator,1} = N_{appl, building,1} \times F_{application, applicator,1} \times Q_{prod,1} \times F_{AI} \times VOLUME_{treated,1} \quad (10)$$

Variable/parameter (units)	Symbol	Unit	Default	S/D/O/P
Input:				
Number of applications per day per building: - non-professional - professional	$N_{appl, building,1}$	d ⁻¹	4 -	D S
Fraction emitted to applicator during application	$F_{application, applicator,1}$	-	0.02	D
Quantity of commercial product applied	$Q_{prod,1}$	kg.m ⁻³	-	S
Volume treated with the product - General air space application (household). - Larger building	$VOLUME_{treated,1}$	m ³	58 -	D S
Fraction of active substance in the commercial product	F_{AI}	-	-	S
Output:				
Emission to the applicator during application step	$E_{application, applicator,1}$	kg.d ⁻¹	-	-

- Treatment of a surface:

$$E_{application, applicator,1} = N_{appl, building,1} \times F_{application, applicator,1} \times Q_{prod,1} \times F_{AI} \times AREA_{treated,1} \quad (11)$$

Variable/parameter (units)	Symbol	Unit	Default	S/D/O/P
Input:				
Number of applications per day per building:	$N_{appl, building,1}$	d ⁻¹		
- non-professional				
- professional			1	D
			-	S
Fraction emitted to applicator during application	$F_{application, applicator,1}$	-	0.11	D
Quantity of commercial product applied	$Q_{prod,1}$	kg.m ⁻²	-	S
Area treated with the product	$AREA_{treated,1}$	m ²		P
- target spot application (household)				2
- general spray application (household)				22
- Other kind of building				-
Fraction of active substance in the commercial product	F_{AI}	-	-	S
Output:				
Emission to the applicator during application step	$E_{application, applicator,1}$	kg.d ⁻¹	-	-

- Emission to Treated Area:

This sub-scenario concerns only the treatment of surfaces. In case of air space treatments, the insecticide falls on the floor or goes outdoors through the ventilation.

$$E_{application,treated,1} = Q_{prod,1} \times F_{AI} \times N_{appl,building,1} \times F_{application,treated,1} \times AREA_{treated,1} \quad (12)$$

Variable/parameter (units)	Symbol	Unit	Default	S/D/O/P
Input:				
Number of applications per day per building:	$N_{appl,building,1}$	d ⁻¹	-	
- non-professional				
- professional			1	D
Fraction emitted to treated surfaces during the application	$F_{application,treated,1}$	-	0.85	D
Quantity of commercial product applied	$Q_{prod,1}$	kg.m ⁻²	-	S
Area treated with the product	$AREA_{treated,1}$	m ²		P
- target spot application (household)				
- general spray application (household)				
- larger building				
Fraction of active substance in the commercial product	F_{AI}	-	-	S
Output:				
Emission to treated surfaces during application step	$E_{application,treated,1}$	kg.d ⁻¹	-	-

3.4.2 Gel application

3.4.2.1 **Mixing/loading step**

The products are always sold under a ready to use form. Therefore, no emission is calculated for the preparation step of gels.

3.4.2.2 **Application step**

- Emission to air:

$$E_{application, air, 2} = Q_{prod, point} \times N_{point} \times F_{AI} \times AREA_{treated, 2} \times F_{application, air, 2} \times N_{appl, building, 2} \times 10^{-3} \quad (13)$$

Emissions to air during gel application are also considered to be negligible (see section 3.3.2). Nevertheless, in case specific calculations are needed to estimate emissions to the air, the table below presents detailed calculations and the corresponding default values. The fraction emitted to air during gel application has then to be determined and the default value of 0 to be replaced by this new value.

Variable/parameter (units)	Symbol	Unit	Default	S/D/O/P
Input:				
Number of applications per day per building - household - larger building	$N_{appl, building, 2}$	d ⁻¹	1 -	S
Number of gel point per square meter: preventive treatment or low infestation level curative or high infestation level	N_{point}	point.m ⁻²	1 3	P
Fraction emitted to air during application	$F_{application, air, 2}$	-	0	D
Quantity of commercial product applied per point of gel:	$Q_{prod, point}$	g.point ⁻¹	-	S
Fraction of active substance in the commercial product	F_{AI}	-	-	S
Area treated with the product Household Larger building	$AREA_{treated, 2}$	m ²	132 -	D S
Output:				
Emission to air during application step	$E_{application, air, 2}$	kg.d ⁻¹		

- Emission to the applicator:

$$E_{application, applicator,2} = Q_{prod, point} \times N_{point} \times F_{AI} \times AREA_{treated,2} \times F_{application, applicator,2} \times N_{appl, building,2} \times 10^{-3} \quad (14)$$

In relation with the form of the product and the way of application, it can be assumed that the fraction emitted to the applicator during the application is suggested to be negligible (see section 3.3.2) unless more specific data available.

Nevertheless, in case specific calculations are needed to estimate emissions to the applicator, the table below presents detailed calculations and the corresponding default values. The fraction emitted to the applicator during gel application has then to be determined and the default value of 0 to be replaced by this new value.

Variable/parameter (units)	Symbol	Unit	Default	S/D/O/P
Input:				
Number of applications per day per building - household - larger building	$N_{appl, building,2}$	d ⁻¹	1 -	S
Number of gel point per area: - preventive treatment or low infestation level - curative or high infestation level	N_{point}	point.m ⁻²	1 3	P
Fraction emitted to the applicator during application	$F_{application, applicator,2}$	-	0	D
Quantity of commercial product applied per point of gel:	$Q_{prod, point}$	g.point ⁻¹		S
Fraction of active substance in the commercial product	F_{AI}	-	-	S
Area treated with the product - Household - Larger building	$AREA_{treated,2}$	m ²	132 -	D S
Output:				
Emission to the applicator during application step	$E_{application, applicator,2}$	kg.d ⁻¹		

- Emission to treated surfaces:

Due to the nature of gel baits and the application mode it has been assumed as a default that the emissions to air ($E_{application, air}$) and the applicator ($E_{application, applicator}$) are negligible.

Therefore, emissions during gel applications are mainly due to emissions to treated surface:

$$E_{application, treated, 2} = Q_{prod, point} \times N_{point} \times F_{AI} \times AREA_{treated, 2} \times F_{application, treated, 2} \times N_{appl, building, 2} \times 10^{-3} \quad (15)$$

Variable/parameter (units)	Symbol	Unit	Default	S/D/O/P
Input:				
Number of application per day - household - larger building	$N_{appl, building, 2}$	d ⁻¹	1 -	 S
Number of gel point per area: - preventive treatment or low infestation level - curative or high infestation level	N_{point}	point.m ⁻²	1 3	P
Fraction emitted to treated surfaces during application	$F_{application, treated, 2}$	-	1	D
Quantity of commercial product applied per point of gel:	$Q_{prod, point}$	g.point ⁻¹	-	S
Fraction of active substance in the commercial product	F_{AI}	-	-	S
Area treated with the product - Household - Larger building	$AREA_{treated, 2}$	m ²	132 -	D S
Output:				
Emission to treated surfaces during application step	$E_{application, treated, 2}$	kg.d ⁻¹		

- Cleaning step:

As explained above, the product is applied in protected areas where there is normally no cleaning. Nevertheless, it might be considered that for some insects, releases might be possible. For example, for the cockroaches, the product is found in the faeces that could be deposited in areas available to cleaning events. Moreover it is not excluded that a fraction of the product applied could be eliminated through cleaning event.

The relevant cleaning method is by water. The cleaning step is detailed in the section 3.5.1.

3.4.3 Application of powders by dusting

3.4.3.1 Mixing/loading step

For the powder/granule insecticides, it is assumed that no mixing step is needed. For general public, the products are most of the time sold under a ready to use form. Besides, professionals often use devices to apply powder and granules. A picture gives an example at the section 2.4.3.

- Emission to air:

In relation with the form of the product and the way of application, it is assumed that the fraction emitted to air during the mixing/loading step is negligible (see section 3.2) unless more specific data available.

Nevertheless, in case specific calculations are needed to estimate emissions to the air, the table below presents detailed calculations and the corresponding default values. The fraction emitted to the air during the mixing/loading step for dusting applications has then to be determined and the default value of 0 to be replaced by this new value.

$$E_{prep, air,3} = Q_{prod, prep,3} \times F_{AI} \times N_{prep, building,3} \times F_{prep, air,3} \times 10^{-3} \quad (16)$$

Variable/parameter (units)	Symbol	Unit	Default	S/D/O/P
Input:				
Quantity of commercial product used for the preparation per building.	$Q_{prod, prep,3}$	g	-	S
Fraction of active substance in the commercial product	F_{AI}	-	-	S
Number of preparations per day per building: house larger building	$N_{prep, building,3}$	d ⁻¹	1 3	P
Fraction emitted to air [-]	$F_{prep, air,3}$	-	0	D
Output:				
Emission to air during preparation step	$E_{prep, air,3}$	kg.d ⁻¹	-	-

- Emission to applicator:

In the same way, it is assumed that the fraction emitted to the applicator during the mixing/loading step is negligible (see section 3.2).

Nevertheless, in case specific calculations are needed to estimate emissions to the applicator, the table below presents detailed calculations and the corresponding default values. The fraction emitted to the applicator during the mixing/loading step for dusting applications has then to be determined and the default value of 0 to be replaced by this new value.

$$E_{prep, applicator,3} = Q_{prod, prep,3} \times F_{AI} \times N_{prep, building,3} \times F_{prep, applicator,3} \times 10^{-3} \quad (17)$$

Variable/parameter (units)	Symbol	Unit	Default	S/D/O/P
Input:				
Quantity of commercial product used for the preparation per building	$Q_{prod, prep,3}$	g	-	S
Fraction of active substance in the commercial product	F_{AI}	-	-	S
Number of preparations per day per building: house larger building	$N_{prep, building,3}$	d ⁻¹	1 3	P
Fraction emitted to applicator during preparation step	$F_{prep, applicator,3}$	-	0	D
Output:				
Emission to applicator during preparation step	$E_{prep, applicator,3}$	kg.d ⁻¹	-	-

- Emission to floor:

$$E_{prep, floor,3} = Q_{prod, prep,3} \times F_{AI} \times N_{prep, building,3} \times F_{prep, floor,3} \times 10^{-3} \quad (18)$$

Variable/parameter (units)	Symbol	Unit	Default	S/D/O/P
Input:				
Quantity of commercial product used for the preparation per building	$Q_{prod, prep,3}$	g	-	S
Fraction of active substance in the commercial product	F_{AI}	-	-	S
Number of preparations per day per building: house larger building	$N_{prep, building,3}$	d ⁻¹	1 3	P
Fraction emitted to floor during preparation step [-]	$F_{prep, floor,3}$	-	0.01	D
Output:				
Emission to floor during preparation step	$E_{prep, floor,3}$	kg.d ⁻¹	-	-

3.4.3.2 Application step

For the emission, a distinction is done between the wettable powders that are sprayed (see the section 3.4.1.2) and the “powders including the “tracking powders” that are dusted.

- Emission to air during the application :

$$E_{application, air, 3} = N_{appl, building, 3} \times F_{application, air, 3} \times Q_{prod, 3} \times F_{AI} \times AREA_{treated, 3} \quad (19)$$

Variable/parameter (units)	Symbol	Unit	Default	S/D/O/P
Input:				
Number of applications per day per building	$N_{appl, building, 3}$	d ⁻¹	1	D
Fraction emitted to air during application	$F_{application, air, 3}$	-	0.02	D
Quantity of commercial applied	$Q_{prod, 3}$	kg.m ⁻²	-	S
Fraction of active substance in the commercial product	F_{AI}	-	-	S
Area treated with the product	$AREA_{treated, 3}$	m ²		
- Surface dusting crack and crevice			2	P
- Surface dusting broadcast			22	
- Larger building			-	S
Output:				
Emission to air during application step	$E_{application, air, 3}$	kg.d ⁻¹	-	-

- Emission to treatment surface during the application:

$$E_{application, treated,3} = N_{appl, building,3} \times F_{application, treated,3} \times Q_{prod,3} \times F_{AI} \times AREA_{treated,3} \quad (20)$$

Variable/parameter (units)	Symbol	Unit	Default	S/D/O/P
Input:				
Number of applications per day per building	$N_{appl, building,3}$	d ⁻¹	1	D
Fraction emitted to Floor during application	$F_{application, treated,3}$	-	0.8	D
Quantity of commercial product applied	$Q_{prod,3}$	kg.m ⁻²	-	S
Fraction of active substance in the commercial product	F_{AI}	-	-	S
Area treated with the product	$AREA_{treated,3}$	m ²		
- Surface dusting crack and crevice			2	P
- Surface dusting broadcast			22	
- Larger building			-	S
Output:				
Emission to treated surface during application step	$E_{application, treated,3}$	kg.d ⁻¹	-	-

- Emission to floor during the application:

$$E_{application, floor,3} = N_{appl, building,3} \times F_{application, floor,3} \times Q_{prod,3} \times F_{AI} \times AREA_{treated,3} \quad (21)$$

Variable/parameter (units)	Symbol	Unit	Default	S/D/O/P
Input:				
Number of applications per day per building	$N_{appl, building,3}$	d ⁻¹	1	D
Fraction emitted to Floor during application	$F_{application, floor,3}$	-	0.18	D
Quantity of commercial product applied	$Q_{prod,3}$	kg.m ²	-	S
Fraction of active substance in the commercial product	F_{AI}	-	-	S
Area treated with the product	$AREA_{treated,3}$	m ²		
- Surface dusting crack and crevice			2	P
- Surface dusting broadcast			22	
- Larger building			-	S
Output:				
Emission to floor during application step	$E_{application, floor,3}$	kg.d ⁻¹	-	-

- Emission to the applicator during the application:

In relation with the form of the product and the way of application, it is assumed that the fraction emitted to the applicator during a powder broadcast is negligible (see section 3.3.3.2).

Nevertheless, in case specific calculations are needed to estimate emissions to the applicator, the table below presents detailed calculations and the corresponding default values. The fraction emitted to the applicator for dusting applications has then to be determined and the default value of 0 to be replaced by this new value.

$$E_{application, applicator,3} = N_{appl, building,3} \times F_{application, applicator,3} \times Q_{prod,3} \times F_{AI} \times AREA_{treated,3} \quad (22)$$

Variable/parameter (units)	Symbol	Unit	Default	S/D/O/P
Input:				
Number of applications per day per building	$N_{appl, building,3}$	d ⁻¹	1	D
Fraction emitted to applicator during application	$F_{application, applicator,3}$	-	0	D
Quantity of commercial product applied	$Q_{prod,3}$	kg.m ⁻²	-	S
Fraction of active substance in the commercial product	F_{AI}	-	-	S
Area treated with the product	$AREA_{treated,3}$	m ²		
- Surface dusting crack and crevice			2	P
- Surface dusting broadcast			22	
- Larger building			-	S
Output:				
Emission to the applicator during application step	$E_{application, floor,3}$	kg.d ⁻¹	-	-

3.4.4 Indoor injection

3.4.4.1 **Mixing/loading step**

- Emission to air:

In relation with the form of the product and the way of application, it is assumed that the fraction emitted to air during the mixing/loading step is suggested is negligible (see section 3.2) unless more specific data available.

Nevertheless, in case specific calculations are needed to estimate emissions to the air, the table below presents detailed calculations and the corresponding default values. The fraction emitted to the air during the mixing/loading step for injections has then to be determined and the default value of 0 to be replaced by this new value.

$$E_{prep, air, 4} = Q_{prod, prep, 4} \times F_{AI} \times N_{prep, building, 4} \times F_{prep, air, 4} \times 10^{-3} \quad (23)$$

Variable/parameter (units)	Symbol	Unit	Default	S/D/O/P
Input:				
Quantity of commercial product used for the preparation per building.	$Q_{prod, prep, 4}$	g	-	S
Fraction of active substance in the commercial product	F_{AI}	-	-	S
Number of preparations per day house larger building	$N_{prep, building, 4}$	d ⁻¹	1 1	D
Fraction emitted to air [-]	$F_{prep, air, 4}$	-	0	D
Output:				
Emission to air during preparation step	$E_{prep, air, 4}$	kg.d ⁻¹	-	-

- Emission to the applicator during the mixing loading step:

$$E_{prep, applicator,4} = Q_{prod, prep,4} \times F_{AI} \times N_{prep, building,4} \times F_{prep, applicator,4} \times 10^{-3} \quad (24)$$

Variable/parameter (units)	Symbol	Unit	Default	S/D/O/P
Input:				
Quantity of commercial product used for the preparation per building.	$Q_{prod, prep,4}$	g	-	S
Fraction of active substance in the commercial product	F_{AI}	-	-	S
Number of preparations per day house larger building	$N_{prep, building,4}$	d ⁻¹	1 1	D
Fraction emitted to the applicator [-]	$F_{prep, applicator,4}$	-	Table 3.2-2	P
Output:				
Emission to the applicator during preparation step	$E_{prep, air,4}$	kg.d ⁻¹	-	-

- Emission to floor during the mixing/loading step:

$$E_{prep, floor, 4} = Q_{prod, prep, 4} \times F_{AI} \times N_{prep, building, 4} \times F_{prep, floor, 4} \times 10^{-3} \quad (25)$$

Variable/parameter (units)	Symbol	Unit	Default	S/D/O/P
Input:				
Quantity of commercial product used for the preparation per building.	$Q_{prod, prep, 4}$	g	-	S
Fraction of active substance in the commercial product	F_{AI}	-	-	S
Number of preparations per day house	$N_{prep, building, 4}$	d ⁻¹	1	D
larger building			1	
Fraction emitted to the floor [-]	$F_{prep, floor, 4}$	-	Table 3.2-3 & Table 3.2-4	P
Output:				
Emission to the floor during preparation step	$E_{prep, floor, 4}$	kg.d ⁻¹	-	-

3.4.4.2 Application step

- Emission to air during the application step:

In relation with the form of the product and the way of application, it is assumed that the fraction emitted to air during the injection is negligible (see section 3.3.4.2).

Nevertheless, in case specific calculations are needed to estimate emissions to the air, the table below presents detailed calculations and the corresponding default values. The fraction emitted to the air during the injection has then to be determined and the default value of 0 to be replaced by this new value.

$$E_{application, air,4} = Q_{prod, injected\ drilling} \times N_{drilling} \times Wall_{length} \times N_{appl, building,4} \times F_{AI} \times F_{application, air,4} \times 10^{-3} \quad (26)$$

Variable/parameter (units)	Symbol	Unit	Default	S/D/O/P
Input:				
Quantity of in use product injected per drilling.	$Q_{prod, injected\ drilling}$	g.drilling ⁻¹	-	S
Fraction of active substance in the commercial product	F_{AI}	-	-	S
Number of preparations per day house larger building	$N_{appl, building,4}$	d ⁻¹	1 1	D
Number of drilling per linear meter	$N_{drilling}$	drilling.m ⁻¹		
Length of the perimeter wall of the building House Larger building	$Wall_{length}$	m	50 -	D S
Fraction emitted to the air during the injection of insecticide	$F_{application, air,4}$	-	0	D
Output:				
Emission to air during application step	$E_{application, air,4}$	kg.d ⁻¹	-	-

- Emission to the applicator during the application step:

$$E_{\text{applicatin, applicatorA}} = Q_{\text{prod, injecteddrilling}} \times N_{\text{drilling}} \times Wall_{\text{length}} \times N_{\text{appl, buildingA}} \times F_{AI} \times F_{\text{applicatin, applicatorA}} \times 10^{-3} \quad (27)$$

Variable/parameter (units)	Symbol	Unit	Default	S/D/O/P
Input:				
Quantity of in use product injected per drilling.	$Q_{\text{prod, injected drilling}}$	g.drilling ⁻¹	-	S
Fraction of active substance in the product applied	F_{AI}	-	-	S
Number of preparations per day house larger building	$N_{\text{appl, building,4}}$	d ⁻¹	1 1	D
Number of drilling per linear meter	N_{drilling}	drilling.m ⁻¹		
Length of the perimeter wall of the building House Larger building	$Wall_{\text{length}}$	m	50 -	D S
Fraction emitted to the applicator during the injection of insecticide	$F_{\text{application, applicator,4}}$	-	0.01 ^h	D
Output:				
Emission to the applicator during application step	$E_{\text{application, applicator,4}}$	kg.d ⁻¹	-	-

^h This proposed value is presented in the Table 3.3-6.

- Emission to the floor during the application step:

$$E_{\text{application, floor,4}} = Q_{\text{prod, injected drilling}} \times N_{\text{drilling}} \times Wall_{\text{length}} \times N_{\text{appl, building4}} \times F_{AI,2} \times F_{\text{application, floor,4}} \times 10^{-3} \quad (28)$$

Variable/parameter (units)	Symbol	Unit	Default	S/D/O/P
Input:				
Quantity of in use product injected per drilling.	$Q_{\text{prod, injected drilling}}$	g.drilling ⁻¹	-	S
Fraction of active substance in the product applied	F_{AI}	-	-	S
Number of preparations per day house larger building	$N_{\text{appl, building,4}}$	d ⁻¹	1 1	D
Number of drilling per linear meter	N_{drilling}	drilling.m ⁻¹		
Length of the perimeter wall of the building House Larger building	$Wall_{\text{length}}$	m	50 -	D S
Fraction emitted to the floor during the injection of insecticide	$F_{\text{application, floor,4}}$	-	0.05	D
Output:				
Emission to the floor during application step	$E_{\text{application, floor,4}}$	kg.d ⁻¹	-	-

- Emission to the treated material (wall/floor) during the application step:

$$E_{application, treated, 4} = Q_{prod, injected drilling} \times N_{drilling} \times Wall_{length} \times N_{appl, building, 4} \times F_{AI} \times F_{application, treated, 4} \times 10^{-3} \quad (29)$$

Variable/parameter (units)	Symbol	Unit	Default	S/D/O/P
Input:				
Quantity of in use product injected per drilling.	$Q_{prod, injected drilling}$	g.drilling ⁻¹	-	S
Fraction of active substance in the product applied	F_{AI}	-	-	S
Number of preparations per day house larger building	$N_{appl, building, 4}$	d ⁻¹	1 1	D
Number of drilling per linear meter	$N_{drilling}$	drilling.m ⁻¹		
Length of the perimeter wall of the building House Larger building	$Wall_{length}$	m	50 -	D S
Fraction emitted to the treated volume during the injection of insecticide	$F_{application, treated, 4}$	-	0.949 ⁱ	D
Output:				
Emission to the treated volume of wall/floor during application step	$E_{application, treated, 4}$	kg.d ⁻¹	-	-

ⁱ This proposed value is presented in the Table 3.3-6

3.4.5 Fumigant/gas3.4.5.1 **Mixing loading step**

For the fumigants and gases, the products are always in a ready to use form.

3.4.5.2 **Application Step**

A similar scenario has been developed for USES 3.0 for fumigation of buildings, silos (van der Poel *et al.* 2002).

$$E_{local, air, 5} = \frac{Q_{prod, 5} \times (1 - F_{ret}) \times (1 - F_{disin})}{T_{emission}} \quad (30)$$

Variable/parameter (units)	Symbol	Unit	Default	S/D/O/P
Input:				
Amount used	$Q_{prod, 5}$	kg		S
Fraction of retention in goods - fumigant - gas	F_{ret}	(-)	0.02	D
Fraction of disintegration: - fumigant - gas	F_{disin}	(-)	0.001	D
Number of emission days for treatment	$T_{emission}$	d	1	D
Output:				
Local emission to air during episode	$E_{local, air, 5}$	kg.d ⁻¹		

Using all the above suggested default values: $E_{local, air, 5} = 0.979 \times Q_{prod, 5}$

3.4.6 Diffusers

These products are designed for the control of flying insects. The equations below were developed for “general diffusers”. For the diffusers used in furniture, the equations could be used.

3.4.6.1 Mixing/loading step

The products are always sold under a ready to use form. Therefore, no emission is calculated for the preparation step of diffusers.

3.4.6.2 Application step

- Emission to air:

$$E_{application, air,6} = Q_{prod,6} \times F_{AI} \times \frac{T_{Day}}{T_{Max}} \times F_{application, air,6} \times 10^{-3} \quad (31)$$

Variable/parameter (units)	Symbol	Unit	Default	S/D/O/P
Input:				
Quantity of commercial product contained in the device/diffuser	$Q_{prod,6}$	g	-	S
Maximal duration of use of the device/diffuser (autonomy)	T_{Max}	h	-	S
Fraction of active substance in the commercial product	F_{AI}	-	-	S
Duration of use per day (electrical) (passive)	T_{Day}	h.d ⁻¹	8 24	D
Fraction emitted to air during the use	$F_{application, air,6}$	-	0.9	D
Output:				
Emission to air during the use of the device/diffuser	$E_{application, air,6}$	kg.d ⁻¹	-	-

- Emission to floor:

$$E_{application, floor, 6} = Q_{prod, 6} \times F_{AI} \times \frac{T_{Day}}{T_{Max}} \times F_{application, floor, 6} \times 10^{-3} \quad (32)$$

Variable/parameter (units)	Symbol	Unit	Default	S/D/O/P
Input:				
Quantity of commercial product contained in the device/diffuser	$Q_{prod,6}$	g	-	S
Maximal duration of use of the device/diffuser (autonomy)	T_{Max}	h	-	S
Fraction of active substance in the commercial product	F_{AI}	-	-	S
Duration of use per day (electrical) (passive)	T_{Day}	h.d ⁻¹	8 24	D
Fraction emitted to floor during the use	$F_{application, floor, 6}$	-	0.1	D
Output:				
Emission to the floor during the use of the device/diffuser	$E_{application, floor, 6}$	kg.d ⁻¹	-	-

3.5 Releases at the local scale

3.5.1 Cleaning step

In the scenario, it has been considered that treatment and cleaning steps take place the same day. Emissions due to both steps are added to estimate the final releases into the environment. This is in accordance with the EU emission scenario for products used as PT2 (Private area and public health area disinfectants) developed by (Van der Poel 2000) and its revision under development where it has been considered that 100% of substance emitted per day during application is released to wastewater, assuming a frequency of cleaning events of one time per day and a 100% efficiency in the cleaning).

In addition, in a first approach the degradation of the product is not taken into account in this scenario because there are no data to substantiate the derivation of possible losses due to this process. In the same manner, the degradation of insecticides used in stables and manure storage systems was not taken into account in a first tier approach in the elaboration of the emission scenario document for these substances (OECD 2005).

- **Emission to air:** $E_{cleaning, air}$:

As explained in previous sections, the fraction emitted to air during cleaning events is considered to be negligible. Therefore, releases to air are not considered to be significant.

$$E_{cleaning, air} = 0$$

- **Emission to solid wastes and to waste water during the cleaning step:**

As explained in section previously, two cases are considered:

- cleaning events result only in emissions to wastes : 100% of the surfaces are cleaned by vacuum/broom and the clothes of the applicator are disposable,
- cleaning events result only in emissions to wastewater: 100% of the surfaces are washable and the clothes of the applicator are washed.

In the last case, the efficiency of the cleaning is taken into account as this factor may reduce significantly releases to the environment (see cleaning efficiency factors as proposed in Table 3.3–8).

- First case: releases to solid wastes

All the releases are directed to solid wastes during cleaning including those emitted by the applicator (when disposing PPE).

- 100% of the coveralls are disposable then $F_{applicator, w} = 1$ and $F_{applicator, ww} = 0$
- 100% of the surfaces are cleaned by vacuum/broom, then $F_w = 1$ and $F_{ww} = 0$

- Emissions from the applicator

$$E_{applicator, w} = (E_{prep, applicator} + E_{application, applicator}) \times F_{applicator, w} \quad (33)$$

Variable/parameter (units)	Symbol	Unit	Default	S/D/O/P
Input:				
Emission to applicator during the preparation step.	$E_{prep, applicator}$	kg.d ⁻¹		O
Emission to applicator during the application step.	$E_{application, applicator}$	kg.d ⁻¹		O
Fraction emitted to solid wastes from applicator after the application	$F_{applicator, w}$	-		P
Disposable coveralls			1	
Washable coveralls			0	
Output:				
Emission from applicator to solid waste during the cleaning step	$E_{applicator, w}$	kg.d ⁻¹	-	-

- Emission from floor/treated:

$$E_{treated, w} = (E_{prep, floor} + E_{application, floor} + E_{application, treated}) \times F_w \times F_{CE} \quad (34)$$

Variable/parameter (units)	Symbol	Unit	Default	S/D/O/P
Input:				
Emission to floor during the preparation step.	$E_{prep, floor}$	kg.d ⁻¹		O
Emission to floor during the application step.	$E_{application, floor}$	kg.d ⁻¹		O
Emission to treated surfaces during the application step	$E_{application, treated}$	kg.d ⁻¹		O
Fraction emitted to solid waste during the cleaning step	F_w	-	1	D
Cleaning efficiency	F_{CE}	-	Table 3.3-8	P
Output:				
Emission from floor/treated to solid waste during the cleaning step	$E_{treated, w}$	kg.d ⁻¹	-	-

- Second case: Releases to waste water:

All releases are directed to waste water during cleaning including those emitted by the applicator (when washing its PPE)

- 100% of the coveralls are washable then $F_{applicator, w} = 0$ and $F_{applicator, ww} = 1$

- 100% of the surfaces are cleaned with water, then $F_{ww} = 1$ and $F_w = 0$

- Emissions from the applicator

$$E_{applicator, ww} = (E_{prep, applicator} + E_{application, applicator}) \times F_{applicator, ww} \quad (35)$$

(For the treatment of volume, $E_{application, treated} = 0$)

Variable/parameter (units)	Symbol	Unit	Default	S/D/O/P
Input:				
Emission to applicator during the preparation step.	$E_{prep, applicator}$	kg.d ⁻¹		O
Emission to applicator during the application step.	$E_{application, applicator}$	kg.d ⁻¹		O
Fraction emitted to waste water from applicator after the application	$F_{applicator, ww}$	-		P
Disposable coveralls			0	
Washable coveralls			1	
Output:				
Emission from applicator to waste water during the cleaning step	$E_{applicator, ww}$	kg.d ⁻¹	-	-

- Emission from floor/treated:

$$E_{treated, ww} = (E_{prep, floor} + E_{application, floor} + E_{application, treated}) \times F_{ww} \times F_{CE} \quad (36)$$

(For the volume treatment, $E_{application, treated} = 0$)

Variable/parameter (units)	Symbol	Unit	Default	S/D/O/P
Input:				
Emission to floor during the preparation step.	$E_{prep, floor}$	kg.d ⁻¹		O
Emission to floor during the application step.	$E_{application, floor}$	kg.d ⁻¹		O
Emission to treated surfaces during the application step	$E_{application, treated}$	kg.d ⁻¹		O
Fraction emitted to waste water during the cleaning step	F_{ww}	-	1	D
Cleaning efficiency	F_{CE}	-	Table 3.3-8	P
Output:				
Emission from floor/treated to waste water during the cleaning step	$E_{treated, ww}$	kg.d ⁻¹	-	-

3.5.2 Summary:

$$E_{air} = E_{prep, air} + E_{application, air} + E_{cleaning, air}$$

$$E_{ww} = E_{applicator, ww} + E_{treated, ww}$$

$$E_w = E_{applicator, w} + E_{treated, w}$$

Chapter 4 Scenarios for outdoor applications

The following scenarios were prioritised and established on the basis of the results of the survey conducted among OECD countries governments, the producers/formulators of active substances and products, retailers, and applicators, and with the support of the information available in the published literature.

As described in Chapter 2, household and professional insecticides are available on the market in many forms and display very different application patterns. From the survey, it was concluded that the main scenario to be developed for outdoor control of insects was the spray application around the building (perimeter treatment), with two sub-scenarios: one for flying insects and one for crawling insects (section 4.3.1). For spray applications, two additional scenarios are proposed: one for the treatment of crawling space under the building (see section 4.3.2), and one for the treatment of wasp and hornet nests (section 4.3.3).

As regards other application practices (including gels, powders, baits...), in order to avoid the multiplication of scenarios, it is proposed to use a generic scenario that could be applied to any local application regrouped under the name of “spot application” (section 4.3.4).

The risk of secondary poisoning for birds and mammals consuming contaminated insects or vegetation is considered in 0.

4.1 Release pathways to the environment

Insecticides may be applied outdoors either directly, such as during spray or powder application, or may reach environmental compartments indirectly from spillage during preparation or from *e.g.* bait stations. Additional releases to the environment occur when contaminated insects do not die immediately and carry the active substance to the surrounding area. Social insects may also bring back the active substance with them when returning to the colony.

The fate of the substance released to the environment depends on the location of the treated structures, *i.e.* either in countryside or within a city.

In line with the approach proposed in the European scenario developed for masonry preservatives (Migne 2002), in *urban environments*, it will be considered that the ground surface receiving the emissions will likely consist of non permeable substrates *e.g.* paved, concrete, or asphalt ground. Therefore, releases of insecticides will be washed with rain to the rain water/sewer system. The current situation in OECD countries as regards the generalisation of separate systems for rainwater and wastewater is variable. Depending on national legislation, but also on the city size or precipitations volumes, rain or storm waters will eventually end up in a sewage treatment plant or be collected and released directly to surface waters. In the following scenarios, it will be considered that releases are collected in Sewage Treatment Plant (STP), which will act as a point source.

For separate systems (rain water), it can be considered that no removal takes place at this point source. For EU assessments using EUSES software, that would mean that STP is by-passed.

For mixed waste/rain water systems, (or in other words when STP is not by-passed), the relevant environmental compartments would then be the sewage treatment plant (STP), the surface water, the agricultural soil (from sludge application), and the groundwater. In Europe, estimates of potential exposure resulting from emission via the STP should be carried out according to the standard calculation frameworks presented in the Technical Guidance Document (E.C. 2003).

In *rural areas*, releases will end up on unpaved soil. The relevant environmental compartments will here be the soil and the groundwater.

It should be noted that according to the survey performed by (Vosswinkel *et al.* 2003) in Germany, about 50% of the private houses own a garden. Although this result may not be representative of other OECD countries, it may be considered as an indication that half of the outdoor treatments are likely to reach directly the soil.

It is agreed that emissions to soil may occur in urban environment and conversely that rural regions may have connection to a sewer system. For the purpose of the risk assessment of insecticides it is proposed to use two theoretical environments where 100% of the releases end up to soil in rural environment and 100% of the releases are sent to sewers in urban area. The risk has to be assessed for both environments.

The present document provides primarily models to calculate emission values, but will also give guidance in order to calculate local concentrations in both urban and rural areas. As regards groundwater contamination, previous scenarios have provided guidance for the calculation of concentration in groundwater. For the purpose of this scenario, existing models should be used. In the European risk assessment context, models from the EU TGD (E.C. 2003) or the use of FOCUS ground water should be considered. For the latter, default values for garden size are proposed in order to calculate equivalent per-hectare application rates.

Releases to the air compartment may be considered, mainly when the insecticide is a gas or has a high vapour pressure. In other cases, such as during sprayer application, liquid droplets or solid particles sprayed outdoor are not expected to remain airborne but will eventually settle on the ground. Settling time may be longer when the material used forms a fine mist *e.g.* during nebulisation. However, when insecticides are used outdoor, effects on non-target species are expected to be low because of instant dilution and turbulence in air. Exposure of the air compartment is thus limited in time and restricted to local scale.

Release pathways foreseen for the outdoor use of insecticides are depicted in

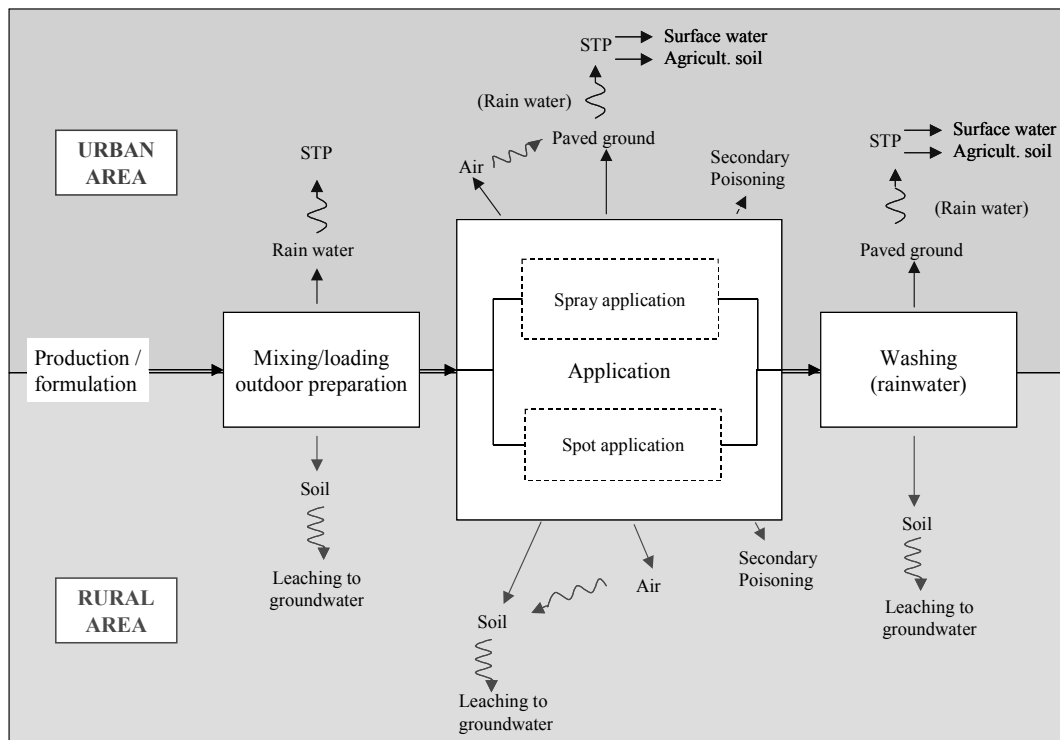

Figure 4.1-1: Release pathway foreseen for the outdoor use of insecticides.

It has to be recalled that the production and formulation stages are outside the scope of the present document.

Table 4.1-1 summarises the receiving environmental compartments that have been considered as potentially exposed during the different steps of the use of insecticidal products for the different scenarios considered in this document. Details are provided in the following chapters.

Table 4.1-1: Environmental receiving compartments potentially exposed during the outdoor use of insecticides

Main scenario	Sub-scenario	Environmental compartments					Secondary poisoning
		Air	STP	Soil	Surface water	Ground water	
Mixing/ loading	All applications (rural)	(+)		++		+	(+)
	All applications (urban)	(+)	++	+	+	(+)	(+)
Spray application	Flying insects (rural)	(+)		++		+	+
	Flying insects (urban)	(+)	++	+	+	+	+
	Crawling insects (rural)	(+)		++		+	+
	Crawling insects (urban)	(+)	++	+	+	+	+
	Wasp/hornet (rural)	(+)		++		+	+
	Wasp/hornet (urban)	(+)	++	+	+	+	+
bait station/ traps	Ant bait stations (rural/urban)		(++)	++	(+)	+	+
	Traps for flying insects (volatile insecticide) (rural/urban)	(+)		(+)			+
Diffuser	All (rural/urban)	(+)		(+)			+
Powder	Ant nest (rural/urban)	(+)		++		+	+
Gel	rural/(urban)	-	(++)	++	(+)	+	++

++ Compartment primarily exposed (soil, STP)

+ Compartment secondarily exposed (surface water from STP discharge, agricultural soil from sludge application, groundwater further to soil exposure, vertebrates eating contaminated insects)

(+) Compartment potentially exposed

4.2 Releases estimation for outdoor mixing/loading step

4.2.1 Receiving compartment

When the product is only used outdoors, the mixing/loading step may be performed inside or outside a building nearby. In the present scenario, as worst case, it will be considered that when the product is applied outdoors, it is also prepared outside the building. In this case releases may occur directly onto the ground. The fate of the substance spilled on the ground depends on the location of the treated structures, *i.e.* either in countryside or within a city. In urban area, insecticides will be washed with rain to the rainwater/sewer system and reach the sewage treatment plant (STP). Releases can then occur to the surface water from STP discharge, to agricultural soil from sludge application and eventually to groundwater. In rural area, losses will end up directly on unpaved soil and eventually to groundwater.

The environmental receiving compartments to consider are summarized in Table 4.2-1.

Table 4.2-1: Receiving compartments for insecticide during the mixing/loading

Location	Step	Receiving compartments
Rural area	Mixing/loading	Soil (Groundwater) ¹
Urban area	Mixing/loading	STP / Surface water (Agricultural soil) (Groundwater)

¹⁾ Contamination of groundwater due to mixing/loading on unpaved ground (rural area) is not expected to be significant.

4.2.2 Emission factor

Emission factors for mixing/loading step have been defined in indoor section 3.2. The operations performed by the applicator are expected to be equivalent if they are performed inside or outside a building. The only difference is that the spilled product will directly reach outdoor ground instead of indoor floor. Therefore, the same emission factors as those used for indoor preparation will be used (see section 3.2).

4.2.3 Size of the receiving compartment

Spillage during the preparation of the spray mixture occurs around the spraying apparatus and the operator. Similarly, releases during the setting of bait insecticide in a trap will take place around the applicator (see Figure 4.2-1).

As default value, a circular receiving compartment of 1-meter diameter is proposed. In order to take into account the modifications proposed in EU to adapt other scenarios such as the OCDE scenario for wood preservatives (OECD 2003), a depth value of 50 cm is chosen. As discussions on relevant depths and critical distances are continuing and knowledge on the subject is just developing, the included calculations must be considered as examples only. Definitive decisions will be made at a later stage

$$V_{prep,soil} = 0.40 \text{ m}^3$$

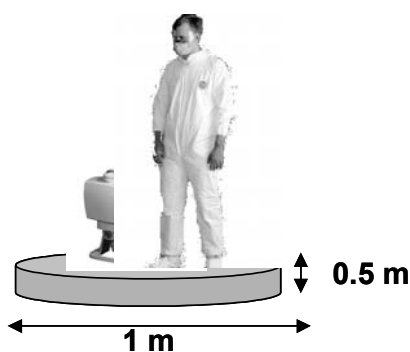

Figure 4.2-1 Receiving compartment during the mixing loading step outdoors.

4.2.4 Summary for the outdoor preparation step

Table 4.2-2: Default values for the outdoor preparation step

Variable/parameter	Symbol	Unit	Default	S/D/O/P
Fraction emitted to ground/soil during preparation step [-]	$F_{prep,soil}$	-	See Table 3.2-3 and Table 3.2-4	P
Soil volume for the mixing/loading step	$V_{prep,soil}$	m ³	0.40	D

4.3 Releases estimation for outdoor application scenarios

4.3.1 Spray application: Treatment around the building

4.3.1.1 Use pattern of outdoor spray insecticides

This section aims to depict the use pattern of sprayed insecticides in outdoor conditions. For the purpose of the present document, only chemical strike is considered. However, whatever the insecticide treatment used, it has to be accompanied by a general sanitation of the area.

Crawling insects

A full eradication of ants from an outdoor area can generally not be achieved. However, a perimeter treatment consisting in applying a residual insecticide by spray around the building may contribute to reduce the infestation of building.

Similarly, as regards cockroaches, it may be deemed necessary to build an outdoor barrier using residual sprays on thresholds and other entrances, the low parts of the walls (foundations), and soil adjacent to the foundations, to prevent the invasion of the building.

According to the survey conducted during the preparation of the scenario, spray application (mainly aerosol when performed by general public or manual sprayer when performed by professional) is the main application for the outdoor control of spiders. The products placed on the market for spray application are either liquid, auto-dispersible granules, or wettable powders, but if they are effective on spiders, they are usually not specific. They are both preventive and curative.

The protective application of spray for termite control is already partially covered in the OECD ESD for wood preservatives in which house's foundations treatment is included. However, the OECD scenario for wood preservatives does not cover spray application for curative termite control (see Table 2.1-1).

For the treatment around buildings, including application to soil, rather different emissions are anticipated and it is therefore considered that the following scenario should also apply on termite treatment.

Overall, the goal of spray application in outdoor treatment of crawling insects is to build a chemical barrier, also designated as *perimeter treatment around buildings*, which is achieved by applying insecticide to the soil/wall junction around the building. The lower region of wall or foundation (the vertical component) that is treated usually ranges from 0.2 to 0.5 m, but may be up to 1 m in height whilst the band of treated soil (the horizontal component) usually ranges from 0.3 to 0.5 m.

Beside a treatment around the building, another practice has been identified which consists in spraying the crawling space under the building. The application method consists in spraying insecticide on the ceiling, the walls and the soil. A scenario has been developed.

Flying insects

Outdoor treatments to control flying insects predominantly concern mosquitoes, flies and hornets or wasp nets.

- General public

The general public may use insecticide sprays, typically aerosol sprays, to control flying insects such as flies or mosquitoes, but in outdoor conditions, the efficacy of such treatment is of local and time limited action. Due to the limited scale of the application and the dilution of the application in the air compartment, no specific scenario will be developed for this application. Diffuse releases by the general public have to be considered together with indoor applications.

Because equipments for the application of outdoor insecticide using sprayers or foggers for adult mosquitoes control are expensive and complex, these more extensive treatments are often performed by professional.

- Treatment by professionals

In case of heavy infestation by houseflies, comfort outdoor treatment targeted against adult flies can be necessary. Spray application on the wall or on any surface used by the fly as resting area may be performed using long-lasting insecticide preferentially by a professional ((Gerry *et al.* 2004)). Instead of treating the whole wall surface, the treatment of doors and windows frames can be deemed sufficient to limit the entrance of unwanted insects.

The use of spray application for mosquitoes in outdoors is usually reserved to severe infestation and related to vector control for disease prevention. In this case mosquito control has to be performed on a large scale by professionals. The management is targeted to the elimination of mosquito larvae by treating water bodies. It is recommended to use products highly specific to mosquitoes, with little or no effect on other organisms.

With the exemption of vector control for disease prevention, it may also be useful to treat walls or entrance borders in order to prevent the entrance of mosquitoes in the building. Hand-held domestic aerosols are usually effective in killing adult mosquitoes. The scenario developed for flies control in the present document covers this application.

The typical representative scenario for flying insects is defined as a spray application on the entire surface of the wall.

Fogging application is not considered as appropriate for this scenario, the size of the droplet being too small to ensure a proper wetting of the surfaces. Such applications will have to be considered together with vector control applications.

In the same way, the treatment of a band of soil around the treated building is not considered as typical for the control of adult flying insects. The literature has shown that ground applications (including pools, vegetations...) are foreseen for the strike against larval stages of mosquitoes. The present scenario does not cover this application.

However, depending on the uses claimed for the product (e.g. larvicide treatments), a treated band of soil around the building should be added.

In the particular case of insecticides for hornets and wasps, the products are formulated in pressurized containers that emit a long and narrow stream of spray. It should be applied to the entrance of the nest. Usually, after one to two days, the empty nest can be removed carefully. A scenario covering this application will be developed in the present document (see section 4.3.2).

4.3.1.2 Selection of scenarios for outdoor spray application

Further to the analysis of the use pattern of spray insecticides used outside the building, 4 scenarios related to spray application are developed in this emission scenario document. The first two scenarios are the main ones:

- 1/ Treatment of flying insects by spray: in this application, it will be considered that the entire wall of the building is treated.
- 2/ Treatment of crawling insects by spray: For this scenario, it will be considered that a chemical barrier against crawling insects is achieved by treating the foundation of the building together with a treated band of soil around the building.

For these two scenarios, releases will be considered during the application step, *i.e.* surface spraying, and further emissions due to washing by rainwater will also be taken into account. When relevant, emissions from the mixing loading step have to be added to these emissions.

- 3/ Treatment of crawling space under building (see section 4.3.2)
- 4/ Treatment of wasp/hornet nests by spray will be treated separately (see section 4.3.3).

4.3.1.3 Receiving compartments

Application step

Outdoor areas subject to insecticide spraying consist of outside surfaces of buildings including, exterior siding, foundations, porches, window frames, eaves, patios, garages, refuse dumps, lawns such as grass areas adjacent or around private homes, apartment complexes, garages, fence lines, storage sheds, barns, warehouse...

- Emission routes that may need to be considered during spray application are:
- Emission to air due to spray application or evaporation
- Emission to soil (direct application, deposition of spray droplets and leaching from vertical surfaces)
- Emission to water (deposition, leaching to surface water or groundwater)

In the EU scenario for masonry preservatives (Migne 2002), an additional spray drift was considered as potential source of releases from wall application. In the present document, no specific distinction will be made between spray drift and spray deposition. For masonry preservatives, the treatment may be performed at a distance from the soil much higher than for insecticides since treatments of the roof are also considered. In addition, during insecticide treatment, the spray is directly orientated to the wall and thus it is expected that the distance travelled by the droplets will be much lower. Therefore, both phenomena will be considered together.

However, as regards the treatment of the band of soil around the house, additional releases related to drift due to direct spray application on soil are considered.

For the purpose of this scenario, two building types have been defined, one being representative of the private home, and the other being representative of industrial or commercial sites, and of public buildings (see section 2.6).

These structures may be located either in countryside or within a city. It will be considered that releases of insecticides in countryside will end up on unpaved soil whereas releases in the city will be washed with rain to the sewer system. Both situations should be considered for a comprehensive exposure assessment.

The receiving compartments for emissions associated with outdoor spray applications of insecticides are summarised in Table 4.3-1. During application on outdoor walls, it is expected that releases will initially occur to the air and that a portion of the droplets will undergo subsequent deposition.

Table 4.3-1: Receiving compartments for insecticide during spray application

Location	Treated surface	Receiving compartments	
		Direct application	Run Off
Rural area	Wall/ Foundation	Air Soil (deposition)	Soil (leaching to groundwater)
	Ground	Air Soil (leaching to groundwater)	Not applicable
Urban area	Wall/ Foundation	Air STP /Surface water (Agricultural soil, groundwater)	STP / Surface water (Agricultural soil)
	Ground	Air STP /Surface water (Agricultural soil, groundwater)	Not applicable

Wash-off by rainfall

Additional releases may occur after application from the treated walls/foundations resulting from the washing of the substance by rainfalls.

In countryside however, the insecticide washed from the treated surface by rainfall may increase the residual concentrations in soil and have to be taken into account.

In urban environments, the substance deposited during application is only transferred to the rainwater/sewage water system during the first rain event. Additional releases from the washing of treated surfaces take place at the same time and have to be added.

The receiving compartments to consider are summarised in Table 4.3-2.

Table 4.3-2: Receiving compartments of releases of insecticide during washing by rainwater

Location	Treated surface	Receiving compartments
		Leaching
Rural area	Wall/ Foundation	Soil (Leaching to groundwater)
Urban area	Wall/ Foundation	STP/ Surface water (Agricultural soil)

4.3.1.4 Treated and untreated surfaces

Treated surfaces

Generic scenarios are proposed for these two application modes, and they aim to cover a large range of actual application practices (*i.e.* a large variety of sprayers, of target organisms...). Therefore, where specific data on the application pattern are available, the surface treated should be recalculated according to the label or material technical data sheet (*e.g.* walls/soil treatment or soil only, different width of treated area, etc...).

The dimensions retained for the typical private house are those of the scenario for wood preservatives (OECD 2003).

The house is 17.5 m long and 7.5 m wide. The height of the walls is 2.5 m (see Figure 4.3-1). Two scenarios have been considered for the outdoor control of insects by spray application:

- Wall application for flying insects: in this case, the entire walls are treated, up to 2.5m;
- Chemical barrier for crawling insects: it is then considered that the treatment of foundation up to 0.5-m height is sufficient to protect the house from infestation, together with a treatment of a 0.5-m wide band of soil.

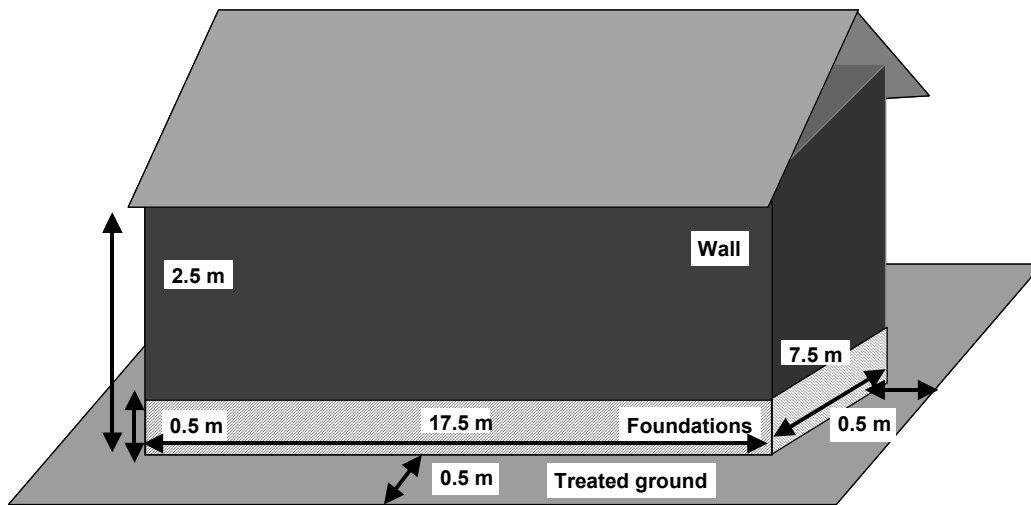

Figure 4.3-1: Schematic drawing of the house with the treated area.

Using the default size value for a typical private house, the following treated areas can be derived.

- Flying insects: Wall application

The surface treated when insecticides are applied on the entire wall *e.g.* for flies control is then: $AREA_{wall} = 125 \text{ m}^2$.

- Crawling insects: perimeter treatment

Foundation application (vertical component)

During perimeter treatment, there may be no need to treat the entire wall and the application will focus on the lower part of the wall (foundations). From the results of the survey performed to build the present scenario and technical data sheets of commercially available formulations, the treatment may be applied from 0.20 m to about 1 m high, the most realistic case being from 0.30 to 0.50 m according to the answers obtained from pest control operators. It has been stressed also that spray bands are often applied in one swath, the width and height of the band being primarily a function of nozzle type and distance from the treated surface but leading to lower band width.

For the calculation of the default wall surface treated during perimeter treatment, the figure of 0.50 m high that will cover most application patterns is chosen.

The treated area for foundations is then $AREA_{foundation} = 25 \text{ m}^2$.

Ground around the house application (horizontal component)

The default size of the treated surface around the house is difficult to determine as practices greatly depend on the infestation type, on the species to control, and on the environment of the building, such as the presence of terrace, patio or lawn around the house, or any element that may provide a source of new infestation. From the results of the survey performed to build this scenario the application of a band ranging from 0.20 m to about 1 m wide is usually recommended.

As for the vertical component, a treated band of 0.5 m wide is proposed. Default values are proposed for particular spot applications such on terraces or pathways in section 4.3.4.2.

The scenario can be easily adapted using specific values if the recommendations for an individual product are to treat a larger band of ground.

The ground area treated around the house is $AREA_{soil} = 26 \text{ m}^2$.

Defaults surface figures to be used for the calculation of the scenario for outdoor spray application on and around the private house are summarised in Table 4.3-3.

Table 4.3-3: Default values for treated surfaces during outdoor spray application around the house

Variable/parameter	Symbol	Unit	Default	S/D/O/P
Area of exterior wall treated per day (private house)	$AREA_{wall}$	$\text{m}^2 \cdot \text{d}^{-1}$	125	D
Area of foundation treated per day (private house)	$AREA_{foundation}$	$\text{m}^2 \cdot \text{d}^{-1}$	25	D
Area of soil treated per day (private house)	$AREA_{soil}$	$\text{m}^2 \cdot \text{d}^{-1}$	26	D

For the purpose of this scenario, a second type of building, representative of the industrial, commercial, or public building have been established (see section 2.6). It has been proposed to use in this scenario a provisional size 5 times bigger than the size of the house, which will cover most of the typical buildings (see section 2.6) (5th meeting of the Task Force on Biocide), until refined data becomes available. .

Defaults values to be used for the treated surfaces during the calculation of the emissions for outdoor spray application on and around the public, commercial, or industrial structures are summarised in Table 4.3-4. These values have been derived assuming a total wall height of 2.5 m (for treatments against flying insects), and for perimeter treatments (crawling insects) a spray band height of 0.5 m and a spray band width of 0.5 m.

Table 4.3-4: Default values for treated surfaces during outdoor spray application around the public, commercial, or industrial, i.e. large structures

Variable/parameter	Symbol	Unit	Default	S/D/O/P
<i>Flying insects</i>				
Surface of exterior wall treated per day (public, commercial, or industrial building)	$AREA_{wall}$	$\text{m}^2 \cdot \text{d}^{-1}$	625	D
<i>Crawling insects</i>				
Surface of foundation treated per day (public, commercial, or industrial building)	$AREA_{foundation}$	$\text{m}^2 \cdot \text{d}^{-1}$	125	D
Surface of soil treated per day (public, commercial, or industrial building)	$AREA_{soil}$	$\text{m}^2 \cdot \text{d}^{-1}$	126	D

Adjacent surfaces (untreated zone)

The above section has defined default values for the treated area, but for the purpose of a risk assessment, it may be necessary to define an additional untreated area, adjacent to the treated zone. As a matter of fact, the application of an insecticide product is expected to cause a risk to the target insect species, but also to non-target species such as other arthropods, if a sufficient selectivity cannot be achieved among insect species. Additional consideration should be given to the possible potential for recovery /recolonisation of non-target populations from the surfaces adjacent to the treated soil. Potential for recovery /recolonisation of non-target species will be achievable only if:

- the population in the adjacent zone remains unaffected;
- the effects of the product are not persistent to allow the return of the organisms.

This would be relevant only for rural areas where a soil compartment is defined.

Default figures for the surface adjacent to the treated zone for outdoor spray application are summarised in Table 4.3-5. The surfaces calculated correspond to a 0.5-m width band around the treated soil.

Table 4.3-5: Default values for surface adjacent to the treated zone during outdoor spray application

Variable/parameter	Symbol	Unit	Default	S/D/O/P
Area of untreated zone	<i>AREA_{untreated}</i>	m ² .d ⁻¹		P
- private house			28	
- public, commercial, or industrial building ¹			128	

¹ Provisional data (5th meeting of the OECD Task force on biocides)

4.3.1.5 Emission factors

Application step

During spray application on wall and foundation surfaces, releases occur to the air compartment and to the ground, either directly from ground application or due to further deposition and run-off from the wall. The receiving compartment will depend upon the location of the treated building. In rural areas the receiving compartment will be soil, whilst in urban area the releases may possibly reach the rain/waste water system. It is proposed that both situations should be considered. For releases estimations, a distinction is made between wall treatments against flying insects (Figure 4.3-2) and “perimeter treatments” against crawling insects (Figure 4.3-3).

- Flying insects: Wall treatment

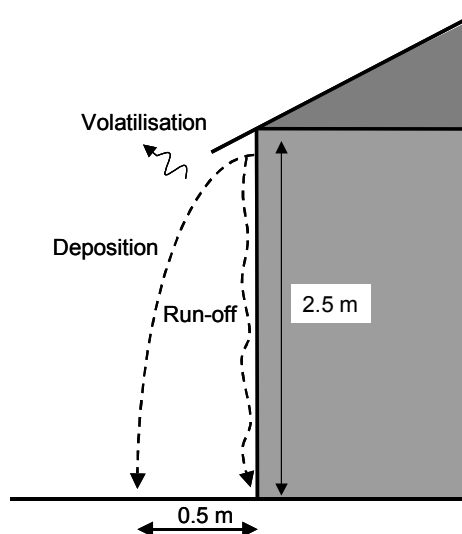

Figure 4.3-2: emissions pathways during spray application on walls against flying insects

- Emission to air

Releases to air will not be further taken into account in this document because of instant dilution and turbulence in air. Additionally, using sprayers, droplets usually range from 100 to 400 μm . In outdoor environments it is generally considered that only droplets less than 50 μm in diameter remain suspended in the air indefinitely or until they evaporate (Landers *in press*).

Exposure of the air compartment is limited in time and restricted to local scale.

$F_{\text{spray,air}}$ is then considered to be negligible from an environmental point of view.

- Emission to soil/rainwater

Emission during spray application onto walls: deposition and run-off:

During spray application on walls, a fraction of the droplets sprayed will not attain the wall but reach the soil compartment through deposition. To our best knowledge, no information is available for the application of insecticides. However, according to the emission scenario for masonry preservatives (Migne 2002) where the application pattern is similar, the fraction of product subject to deposition ranges from 1 to 10%.

In the absence of additional information, it is proposed to use as default value the figure of 10% in this document: $F_{\text{spray,deposition}} = 0.1$

During spray application on walls, a fraction of the spray actually applied on the surface may eventually reach the soil via run-off. Again, according to the emission scenario for masonry preservatives (Migne 2002) where the application pattern is similar, the fraction of product subject to run-off is below or up to 20%.

In the absence of additional information, it is proposed to use as default value the figure of 20% in this document: $F_{\text{spray,run-off}} = 0.2$

These fractions are released on soil in rural area, or will eventually reach the rainwater/sewage water system.

- Crawling insects: Perimeter treatment

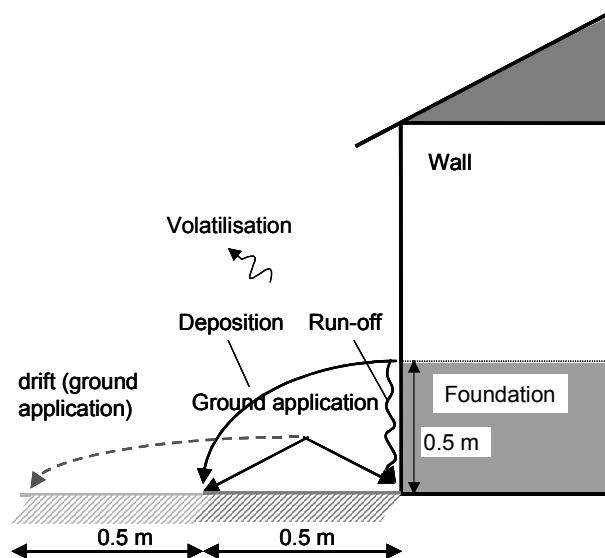

Figure 4.3-3: emissions pathways during spray application on grounds and foundations against crawling insects

- Emission to air

As above, $F_{\text{spray,air}}$ is considered to be negligible from an environmental point of view: $F_{\text{spray,air}} = 0$

- Emission to soil/rainwater

Emission during spray application onto foundations (vertical component): deposition and run-off:

As above for deposition: $F_{\text{spray,deposition}} = 0.1$

and for run-off: $F_{\text{spray,run-off}} = 0.2$

Emission during spray application on soil surface:

When the product is applied directly on the soil surface (i.e. for the horizontal component of a perimeter spray band treatment along the wall/soil boundary), the fraction emitted to the soil is almost 100%. Considering that a fraction of 0.42% is emitted outside the treated zone by drift (see below): $F_{\text{spray,soil}} = 0.99$

These fractions are released on soil in rural area, or will eventually reach the rainwater/sewage water system.

- Emission to soil in the untreated zone

The untreated zone, adjacent to the treated soil may receive insecticide from drift deposition during the treatment of direct application on ground. Spray drift values are available for agricultural sprayer, but results mainly concern mounted sprayer (Ganzelmeier *et al.* 1995)^j.

In this report, drift values are mainly a function of the height of the treated crop. In the case of a treatment of the band of soil around the building using a non-mounted sprayer, the spray altitude is low and similar to that applied on herbicides in the Ganzelmeier study. For this use, the study indicates drift values of about 3% (2.77%) at 1m distance from the point of release. It should be pointed out that this value, derived from agricultural field applications with mounted sprayers might not accurately reflect the actual emissions. Drift values were also proposed by the BBA for home and garden: for horticulture bed with height < 50 cm, the basic drift values in home and garden area for 1 application, in soil expressed in % of the application rate calculated on the basis of the 90th percentile is 0.42%. It is proposed to use this drift value as the default for the emission factor in the untreated zone $F_{\text{spray,untreated soil}} = 0.0042$ (see Table 4.3-6)^k.

If more realistic data are available concerning the potential for exposure to the untreated zone (e.g. experimental or measured data etc.) then these may be used in place of the default, provided that suitable justification is presented.

Table 4.3-6: Emission factors to the untreated zone

Variable/parameter	Symbol	Unit	Default	S/D/O/P
Application				
Fraction emitted to soil during outdoor ground spray application (untreated zone)	$F_{\text{spray,untreated soil}}$	-	0.0042	D

Wash-off of the treated surfaces by rainfall

^j as revised by Rautmann *et. al* (2001) (Rautmann D, Strelake M, Winkler R (2001). New basic drift values in the authorisation procedure for plant protection product. In Foster, R. and Strelake, M: Workshop on Risk Assessment and Risk Mitigation Measures in the Context of the Authorization of Plant Protection Products (WORMM). Mitteilungen aus Biologischen Bundesanstalt für Land- und Forstwirtschaft. Berlin-Dahlem, Heft 381, p133-141.)

^k It should be noticed that in the BBA study and in EU plant protection product assessment, drift values are given as a percentage of the application rate. This corresponds to a default 1-meter width treated band of soil. For further calculations in this ESD, the emission fraction will apply on the quantity applied rather than on the application rate per square metre.

After application, additional releases may occur owing to the wash-off from the walls by rainfall.

In line with the previous calculations, it is assumed that 70% of the product applied remains on the surface of the wall after application.

The quantity of substance that is washed off the wall by rainfall is dependent to some extent on the type of surface that is treated (e.g. concrete, cement, paving, paint). In the absence of validated model, it is proposed to use a default value of 50% of the applied substance washed off the wall during the first rain event ($F_{\text{spray,wash-off}} = 0.5$).

In the OECD scenario for wood preservatives (OECD 2003), the proposed default value for rainfall is 3 rain events, lasting ca. 60 min each, every third day with a precipitation of $4\text{mm}\cdot\text{h}^{-1}$, which corresponds to $1460\text{mm}\cdot\text{y}^{-1}$.

It is proposed to use similar parameters in the present scenario and to consider that the first rain event occurs 3 days after application.

Ideally, the emission from treated surfaces would preferentially be based on experimental data. Although to date, no guidelines are available, a wash-off (or leaching) test performed in the same way as leaching test for wood preservatives would be appropriate. Measured value would then be used in the equation instead of the emission factor $F_{\text{spray,wash-off}}$.

The method developed by (Ramwell 2002), based on OECD guideline for sorption/desorption, for studying the sorption of herbicides to concrete or asphalt is not validated up to now. However, a similar protocol may be envisaged on case-by-case basis to provide desorption data from treated walls.

Depending on regional or national conditions, it may be considered that releases are directed to storm water, or to waste water. Models such as the HardsPEC model (Hollis *et al.* 2004) can also be considered to refine the exposure assessment. This model was developed for non-agricultural herbicides, including substances with high mobility. As first tier assessment, it is expected that the model can apply on non-agricultural insecticides used on hard surfaces. The runoff urban scenario is considered relevant for insecticide application.

Summary of the emission factors

Emission factors to be used for the calculation of the emissions during outdoor spray application are summarised in Table 4.3-7 for flying insects (wall treatment) and in Table 4.3-8 for crawling insects (perimeter treatment).

For treatments against flying insects, the total fraction emitted to soil is coming both from the fraction directly emitted to soil during outdoor wall spray application and from the fraction subject to run-off:

$$F_{\text{spray,wall}} = F_{\text{spray,run-off}} + F_{\text{spray,deposition}} \quad (37)$$

Table 4.3-7: Default values for emission factors during outdoor spray application on walls against flying insects and during further wash-off by rainfall.

Variable/parameter	Symbol	Unit	Default	S/D/O/P
<i>Application</i>				
Fraction emitted to air during outdoor spray application	$F_{spray,air}$	[-]	0	D
Fraction emitted to soil during outdoor wall spray application due to deposition	$F_{spray,deposition}$	[-]	0.1	D
Fraction emitted to soil during outdoor wall spray application due to run-off	$F_{spray,run-off}$	[-]	0.2	D
Total fraction emitted to soil during outdoor wall spray application ¹⁾	$F_{spray,wall}$	[-]	0.3	D
<i>Washing by rain water</i>				
Fraction emitted to soil due to wall wash-off by rainfall	$F_{spray,wash-off}$	[-]	0.5	D

1) Considering that the two fractions due to deposition and run-off will be considered together for emission calculations, they will no longer appear separately and will be pooled together in the next sections of the document.

$$F_{spray,wall} = F_{spray,run-off} + F_{spray,deposition}$$

For treatments against crawling insects, the total fraction emitted to soil is coming both from the fraction directly emitted to soil during outdoor foundation spray application and from the fraction subject to run-off:

$$F_{spray,foundation} = F_{spray,run-off} + F_{spray,deposition} \quad (38)$$

Table 4.3-8: Default values for emission factors during outdoor spray perimeter treatment against crawling insects and during further wash-off by rainfall.

Variable/parameter	Symbol	Unit	Default	S/D/O/P
<i>Application</i>				
Fraction emitted to air during outdoor spray application	$F_{spray,air}$	[-]	0	D
Fraction emitted to soil during outdoor foundation spray application due to deposition	$F_{spray,deposition}$	[-]	0.1	D
Fraction emitted to soil during outdoor foundation spray application due to run-off	$F_{spray,run-off}$	[-]	0.2	D
Total fraction emitted to soil during outdoor foundation spray application ¹⁾	$F_{spray,foundation}$	[-]	0.3	D
Fraction directly emitted to soil during outdoor ground spray application	$F_{spray,soil}$	[-]	0.99	D
Fraction emitted to soil during outdoor ground spray application in the adjacent untreated zone	$F_{spray,untreated\ soil}$	[-]	0.0042	D
<i>Washing by rain water</i>				
Fraction emitted to soil due to foundation wash-off by rainfall	$F_{spray,wash-off}$	[-]	0.5	D

¹⁾ Considering that the two fractions due to deposition and run-off will be considered together for emission calculations, they will no longer appear separately and will be pooled together in the next sections of the document.

$$F_{spray,foundation} = F_{spray,run-off} + F_{spray,deposition}$$

It is assumed that treatments of the walls and of the ground are performed the same day.

No distinction will be made for use practice and emission factors between professionals and the general public.

4.3.1.6 Size of the receiving compartment

In rural areas, the substance is emitted directly in the soil around the building. It is therefore necessary to define the size and the volume of soil receiving the emissions of insecticides in order to calculate local concentrations.

In urban areas, emissions are directed to rainwater/sewer system and local concentrations may be calculated using national or regional models.

Receiving compartments during wall application against flying insects

Releases due to application on walls including from deposition and run-off will reach the soil adjacent to the building. In the OECD scenario on wood preservatives (OECD 2003), the dimensions proposed for the receiving soil compartment was a 10 cm distance from the house and a depth of 10 cm.

However, it was specified that the distance of 10 cm was set in the absence of data and that the ecotoxicological relevance of a band of 10 cm adjacent to the house was not certain. This value was shown to be too stringent and was debated in the framework of the European Biocide Directive (98/8/CE) where it was decided to change the value of 10 cm to 50 cm. In order to be consistent with this amendment it is therefore proposed to calculate the local concentrations with a 50 cm default value for soil depth and for the distance from the treated walls. As discussions on relevant depths and critical distances are continuing and knowledge on the subject is just developing, the included calculations must be considered as examples only. Definitive decisions will be made at a later stage. The receiving compartment is depicted in Figure 4.3-4.

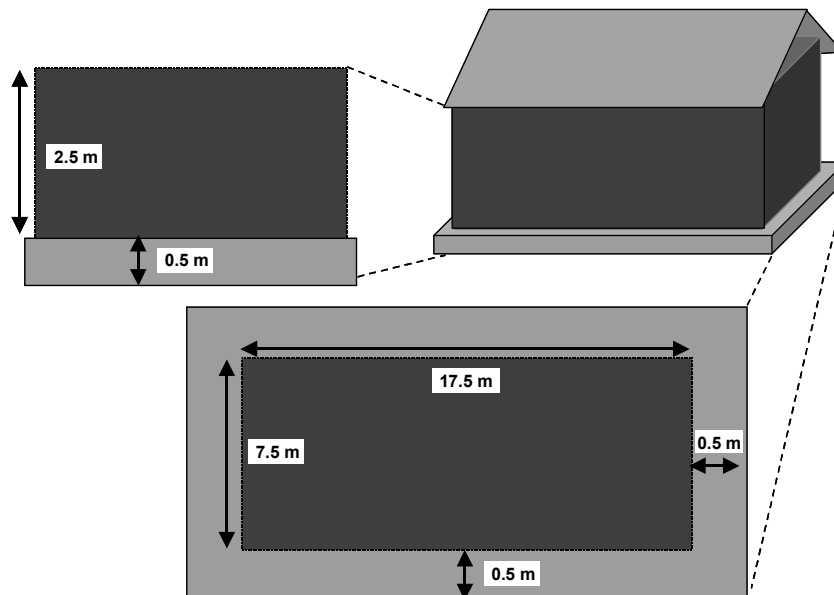

Figure 4.3-4: Schematic drawing of the house with the receiving compartments.

The distance from the wall reached by droplets deposition resulting from walls spraying depends on the distance at which the product is sprayed and on the height of application. When the whole surface is treated, the maximum height of application is 2.5 m. From the outcome of the survey conducted for this scenario and technical data sheets of commercially available formulations, the distance between the sprayer and the surface treated usually ranged from 0.2 to 1 m.

In the scenario for masonry preservatives (Migne 2002), the distance travelled by the droplets was calculated as:

$$S = \frac{U \times H}{V}$$

where S = distance [m]

U = Wind speed [$\text{m}\cdot\text{s}^{-1}$]: 4

H = Height of release [m]:

V = Settling velocity [$\text{m}\cdot\text{s}^{-1}$]: 2.46

Using this equation, spraying at 2.5 m high leads to a calculated distance for droplet deposition of 4.1 m. The spray is however directed onto the wall and it is expected that the distance actually travelled by droplet is probably lower and would not be higher than the distance of application. Furthermore, the wind speed is provided at 10 m high, which is relevant *e.g.* for roof application of masonry preservatives, but is not appropriate for insecticide treatment.

It is therefore proposed to assume that deposition due to the treatment of the walls will occur on a 0.5 m wide treated band around the building.

For the purpose of the present scenario, the deposition is considered to be homogenous on the soil.

Releases from run-off will reach the soil adjacent to the building. In order to be consistent with the distance above, it is assumed that these emissions will take place in a 0.5 m width band around the building.

- Wash-off by rainfall

It is assumed that releases due to wash-off by rainfall from the treated wall ends up in the same volume of soil as emissions due to the application step.

- Summary of default values for the receiving compartment during outdoor spray application on walls against flying insects and further wash-off by rainfall

Table 4.3-9: Default values for the receiving compartment during outdoor spray application on walls against flying insects and further wash-off by rainfall

Variable/parameter	Symbol	Unit	Default	S/D/O/P
Soil volume around building (flying insects)	$V_{\text{spray,soil}}$	m^3		P
- <i>Private house</i>			13	
- <i>Public, commercial or industrial building¹</i>			63	

¹ Provisional data (5th meeting of the OECD Task force on biocides)

Receiving compartments during wall application against crawling insects

It is proposed that emissions due to application on wall (deposition, run-off) during perimeter treatment end up in a 0.5 m band around the building. This will be consistent with the approach retained for wall application during treatment of flying insects. For the purpose of the present scenario, the deposition is considered to be homogenous on the soil.

As regards direct spray application to the soil, the 0.5-m wide band of treated soil corresponds to the surface of the receiving compartment.

It is considered that treatment of the walls and treatment of the soil are performed the same day.

Further to the concentration in the treated zone, concentration may be calculated in the untreated zone receiving only drift deposition from ground application (see Figure 4.3-3).

- Wash-off by rainfall

It is assumed that releases due to wash-off by rainfall from the treated wall ends up in the same volume of soil than emissions due to the application step.

- Summary of default values for the receiving compartment during outdoor spray perimeter treatment against crawling insects and further wash-off by rainfall.

Table 4.3-10: Default values for the receiving compartment during outdoor spray perimeter treatment against crawling insects and further wash-off by rainfall.

Variable/parameter	Symbol	Unit	Default	S/D/O/P
<i>Private house</i>				
Soil volume around private house (crawling insects) directly exposed to perimeter treatment	$V_{\text{spray,soil}}$	m ³	13	D
Soil volume around private house (crawling insects) indirectly exposed to perimeter treatment	$V_{\text{spray,untreated soil}}$	m ³	14	
<i>Public/professional building¹</i>				
Soil volume around public/professional building (crawling insects) directly exposed to perimeter treatment	$V_{\text{spray,soil}}$	m ³	63	D
Soil volume around public/professional building (crawling insects) indirectly exposed to perimeter treatment	$V_{\text{spray,untreated soil}}$	m ³	64	D

¹ Provisional data (5th meeting of the OECD Task force on biocides)

4.3.2 Spray application: Treatment of crawling space

4.3.2.1 Receiving compartments

Table 4.3-11: Receiving compartments of the releases of insecticide during treatment of crawling space

Step	Receiving compartments
Mixing loading step	Air Soil (Groundwater)
Application step	Air Soil (Groundwater)
Cleaning step	Not relevant

As mentioned above, for crawling space treatments, the insecticide is sprayed on the ceiling, the walls and the soil of the crawling space. In the context of this document, it is considered that this scenario is relevant only in rural areas. It is considered that the soil compartment under a house cannot be regarded as a natural environment. The following scenario is however made available considering that it allows also the estimation of groundwater concentrations. It is up to the assessor to use concentrations in soil, depending on national evaluation schemes.

- Private house

In case of curative treatments of a crawlspace, it is proposed to use the following default surfaces for private house:

- Soil surface:

This area corresponds to the surface of the house:

$$AREA_{\text{house}} = 17.5 \times 7.5 = 131 \text{ m}^2$$

- Wall and ceiling surfaces:

The entire surfaces of the walls and of the ceiling are treated. This surface corresponds to 17.5 x 7.5 m for the ceiling and 17.5 x 0.5 x 2 + 7.5 x 0.5 x 2 m for the surface of the wall.

So, the upper surface treated corresponds to

$$AREA_{\text{crawling}} = 17.5 \times 7.5 + 17.5 \times 0.5 \times 2 + 7.5 \times 0.5 \times 2 = 156 \text{ m}^2$$

Table 4.3-12: Default values for treated surfaces during outdoor spray application in the crawling space

Variable/parameter	Symbol	Unit	Default	S/D/O/P
Area of soil under the house treated per day (private house)	AREA _{house(h)}	m ² .d ⁻¹	131	D
Area of upper part of the crawling space treated per day (private house)	AREA _{crawling(h)}	m ² .d ⁻¹	156	D

- Large building

For larger buildings, it is assumed that in case where a crawling space is present, its size is not directly linked to the size of the building. Therefore, when such products are intended to be applied on larger buildings, specific values describing the treated surface will have to be proposed.

4.3.2.2 Emission factors

Application step

During spray applications, releases may occur to the air compartment and to the soil compartment.

- Emission to air

Releases to air will not be further taken into account in this document because of instant dilution and turbulence in air. Exposure of the air compartment is limited in time and restricted local scale.

F_{air} is then considered to be negligible from an environmental point of view. $F_{\text{spray,air}} = 0$

- Emission to soil

Emission factors to be used for the calculation of the emissions during crawling space spray application are not expected to be different from those used for perimeter treatment. An emission factor of 0.2 due to run-off and 0.1 due to deposition is applied.

$F_{\text{spray, run-off}} = 0.2$ and $F_{\text{spray, deposition}} = 0.1$, leading to an overall emission factor of:

$$F_{\text{spray, wall-ceiling}} = 0.3$$

As regards direct application on soil, $F_{\text{soil}} = 1$

Wash-off of the treated surfaces by rainfall

Wash-off is not deemed relevant for this application.

Summary of emission factors for crawling space application

They are summarised in Table 4.3-13

Table 4.3-13: Default values for emission factors during crawling space spray application

Variable/parameter	Symbol	Unit	Default	S/D/O/P
<i>Application</i>				
Fraction emitted to air during crawling space application	$F_{\text{spray,air}}$	[-]	0	D
Fraction emitted to soil during crawling space application due to run-off	$F_{\text{spray,run-off}}$	[-]	0.2	D
Fraction emitted to soil during crawling space application due to deposition	$F_{\text{spray,deposition}}$	[-]	0.1	D
Total fraction emitted to soil during crawling space spray application on walls and ceiling ¹⁾	$F_{\text{spray,wall-ceiling}}$	[-]	0.3	D
Fraction emitted to soil during crawling space spray application on soil ¹⁾	$F_{\text{spray,soil}}$	[-]	1	D
<i>Washing by rain water</i>				
Fraction emitted to soil due to wash-off by rainfall	$F_{\text{spray,crawling,wash-off}}$	[-]	0	D

¹⁾ Considering that the two fractions due to deposition and run-off will be considered together for emission calculations, they will no longer appear separately and will be pooled together in the next sections of the document.

$$F_{\text{spray,wall-ceiling}} = F_{\text{spray,run-off}} + F_{\text{spray,deposition}}$$

4.3.2.3 Size of receiving compartment

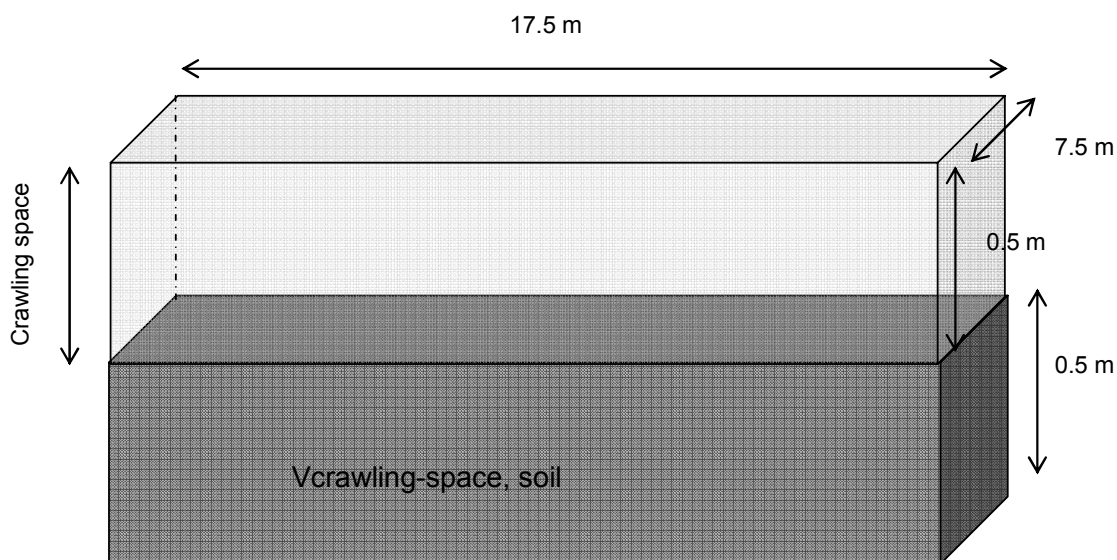

Figure 4.3-5: default parameter for a crawling space

$$V_{\text{crawling space,soil}} = 66 \text{ m}^3$$

4.3.3 Spray application: Treatment of wasp or hornet nests

4.3.3.1 Receiving compartments

In the present document, the surface treated is the nest attached to a tree in countryside which corresponds to a worst-case. For such applications, only local releases to soil are taken into account. Releases to rainwater in urban situation are not considered to be significant.

For spraying nests, two steps exist: the mixing/loading (see section 4.2) and the spray application. Further releases due to washing by rainwater are not relevant for this treatment because all hornets or wasps should be normally dead 24 to 48 hours following the spray application, and subsequently the nest is removed (if not, the application may need to be repeated). Furthermore, it is expected that outdoor treatments are not performed on rainy days.

The receiving compartments to consider are summarised in Table 4.3-14.

Table 4.3-14: Receiving compartments for insecticide during spray applications to wasp and hornet nests

Step	Receiving compartments
Spray application	Air Soil (deposition)

4.3.3.2 Emission factors

During spray applications, releases occur to the air compartment and to the soil compartment.

- Emission to air

Releases to air will not be further taken into account in this document because of instant dilution and turbulence in air. Exposure of the air compartment is limited in time and restricted to local scale.

$F_{\text{spray, nest, air}}$ is then considered to be negligible from an environmental point of view.

- Emission to soil

Wasp or hornet spray insecticides emit a powerful and narrow spray to reach the entrance of the nest. However, during nest spray application, a fraction of the spray droplets will not reach the nest but enter the soil compartment through deposition. No emission data is available in the literature for this application. It is then proposed to use as default value the figure of 30%. $F_{\text{spray, nest, soil}} = 0.3$

4.3.3.3 Size of receiving compartment

In rural areas, the receiving compartment is the soil below and around the nests.

The distance from the nest reached by deposition of spray droplets depends on the distance at which the product is sprayed and of the height of application. It can be considered that the height of application is 2.5 m. This is consistent with the height of the walls proposed in the typical private house (OECD 2003). This distance will cover nests located under the roof.

From the technical data sheets of commercially available formulations, the distance between the sprayer and the surface treated usually ranges from 2 to 6 m and it is proposed to consider a distance of 3 m.

However, wasp or hornet spray insecticides emit a powerful and narrow stream of spray to reach the entrance of the nest. Thus, it is assumed that droplet deposition is maximal below the nests and it is proposed to assume that soil deposition is homogenous and will occur on a 50 cm diameter circular surface.

In accordance with the modification proposed in the EU on the OCDE emission scenario document for wood preservatives (OECD 2003) it is proposed to use a depth of 50 cm.

Summary of default values for the receiving compartment

Default values for the receiving compartment to be used for the calculation of the emissions during spray application of the nests are summarised in Table 4.3-15.

Table 4.3-15: Default values for the receiving compartment during spray application of the nests

Variable/parameter	Symbol	Unit	Default	S/D/O/P
Soil volume for deposition and application at 3 m from the nest	$V_{spray, nest, soil}$	m ³	0.10	D

4.3.4 Spot application

The term of “spot application” is meant to cover the variety of situations in which local applications of insecticide (gel, powder, bait station...) are used on insect pathway or nest to control undesirable organisms.

4.3.4.1 Use patterns of outdoor spot application

Gel application

Answers to the survey performed in order to establish the present scenario as regards outdoor gel application are limited to ant control. These are ready to use products designated for the general public. These products act by ingestion and have mainly a curative action (although preventive uses are not excluded). Material safety data sheets of commercially available products also indicate that outdoor gel applications can be performed in complement to the indoor treatment of cockroaches. It is recommended to treat with small deposits of gel on ant pathways, around terraces, on building entrances such as windows or on wall holes for ants and cockroaches.

Gel should not be applied on porous surfaces. For the purpose of this scenario, it is considered that gels are applied on paved ground such as terraces, but not on bare soil. It is not current practice to collect unconsumed product. Therefore, it is considered that the fraction released during gel application to the environment is 90%, either directly or through ultimate release after target insect death.

$$F_{spot, gel} = 0.9$$

From the description above, the main compartments potentially exposed to substances applied to paved surfaces are the surface water (via rainwater/STP), and subsequently, soil from sludge application and groundwater from soil leaching.

It is not believed however that the outdoor use of gel in city house is the most representative practice. In addition, actual releases to STP following removal of gel product by rainwater are expected to be low, due to losses during transport from application site to STP, and in this case lower than a fraction of 0.9. It might be more likely that a proportion of wash-off from a treated terrace will enter soil in the surrounding garden. Although exposure of STP is possible, it is thus considered that the relevant scenario for outdoor use of gel is the exposure of surrounding garden soil following wash-off of the terrace by rainfall (see Table Table 4.3-164.3-16).

Table 4.3-16: Environmental compartments potentially exposed relative to the use of outdoor gel application

Main scenario	Sub-scenario	Environmental compartments					Secondary poisoning
		Air	STP/ rainwater	Soil	Surface water	Ground water	
Gel application	Ant (rural/urban)	-	(++)	++	(+)	+	++

++ Compartment primarily exposed (soil, STP)

+ Compartment secondarily exposed (surface water from STP discharge, agricultural soil from sludge application, groundwater further to soil exposure, vertebrates eating contaminated insects)

(+) Compartment potentially exposed

Bait stations

Throughout the survey performed in OECD countries, two main types of outdoor bait stations were identified:

- Ant bait stations placed on organisms pathway
- Termite bait stations buried in soil or fixed on walls on organisms pathways.

The wording of 'traps' is often used in place of the appropriate term of 'bait'. Actual traps were identified (see section 2.4.9) but are not further considered for the establishment of an environmental emission scenario. In the case of traps consisting of a reservoir containing a volatile liquid, aimed for the control of flying insects, releases to the environment are not expected to be significant. The limited scale of application, together with air dilution of insecticide vapour is likely to result in negligible potential for air exposure or soil exposure from subsequent deposition.

The use of ant bait stations that are commercially available as ready to use products is ordinarily limited to general public. For the safety of consumer, protection has to be removed, or seals broken before use. Most of the utilisation of these bait stations takes places during spring and summer, when target organism populations increase. They are intended to have a curative action. The insecticides used in ant bait stations act by ingestion/contact and are carried back to the nest by contaminated animals. Example of bait station dimensions would be

- 6 x 6 x 2 cm or 6 cm diameter containing about 5 g of product.
- 7 x 7 x 2 cm plastic boxes containing attractive gel

They are often placed on the market as two- or four-pieces blisters, which seems to correspond to the recommended application. More bait stations can be used in case of more severe infestation but it is likely that other treatments will then have to be applied. Bait stations are placed on ant pathways, generally on hard surfaces such as terrace or patio close to habitation entrance. The placing of these bait stations on bare soil or on lawn is not a regular consumer practice. Therefore, it may be concluded that the most representative scenario would be the use of four bait stations on a terrace. However, it is recommended to rely on specifications of the product to conduct the assessment.

The potential releases to the environment have been considered. In most occasions, bait stations are made of plastic, or possibly cardboard, that would not allow spill of substance around the trap. Therefore, releases may occur from the transport of product by contaminated insects or following flooding from a rain event. As regards termite's traps buried in soil, releases from flooding are considered negligible. At the end of the efficacy period, traps and the potentially remaining product are disposed to municipal wastes.

Information gathered during the survey indicates that about 80% of the product is consumed by the insects whereas 20% remain in the bait station and can be emitted into the environment.

$$F_{spot,bait} = 0.2$$

The environmental compartments potentially exposed are summarised in Table 4.3-17. From the description above, the main compartments potentially exposed to substances applied on paved surfaces are the surface water (through rainwater/STP), and subsequently, soil from sludge application and groundwater from soil leaching. As above (see 4.3.4.1), it is not believed that this scenario is the most representative practice. It might be more likely that a proportion of wash-off from a treated terrace will enter soil in the surrounding garden. Although exposure of STP is possible, it is thus considered that the relevant scenario for outdoor use of baits is the exposure of surrounding garden soil following wash-off of the terrace by rainfall.

Table 4.3-17: Environmental compartments potentially exposed relative to the use of outdoor bait stations

Main scenario	Sub-scenario	Environmental compartments					Secondary poisoning
		Air	STP/ rainwater	Soil	Surface water	Ground water	
Bait station/ traps	Traps for flying insects (volatile insecticide) (rural/urban)	(+)		(+)			+
	Ant bait stations rural/(urban)		(++)	++	(+)	+	+

++ Compartment primarily exposed (soil, STP)

+ Compartment secondarily exposed (surface water from STP discharge, agricultural soil from sludge application, groundwater further to soil exposure, vertebrates eating contaminated insects)

(+) Compartment potentially exposed

Exposure of groundwater compartment is considered to be negligible during the use of bait station.

Diffusers

During the survey conducted prior to the drafting of this ESD, two products belonging to the diffuser category were identified for outdoor uses. Both were dedicated to mosquitoes control by the general public only. No professional application is foreseen.

The first type is a mosquito coil (see description in section 2.4.7 and Figure 2.4-14); the second type consists of tablets that release the insecticide when heated by a candle. These products are expected to have a preventive and a curative function and act by contact. However the action is limited in time corresponding to the burning duration of the coil/candle (about four hours for the latter). It is recommended to place the product at about 4-5 m upwind. In outdoor conditions, 1 or 2 diffusers may be used simultaneously, close to human activity area, e.g. terrace.

It is reminded that for the purpose of the present document, only products containing an insecticide are considered. Candles or other diffusers containing only repulsive substances are out of the scope of this document.

Releases of active substances occur mainly to the air compartment and eventually to the soil compartment due to further deposition. A direct release to the soil from the tablets is not expected and any remaining active substance in the tablet after utilisation will most likely ends up as a waste. Direct releases from mosquito coils may occur from rain action on unconsumed material or from dispersion of ashes by the wind. Otherwise, collected ashes in the support will be directed to the waste and the fraction remaining on the support will be rinsed and will finally reach the wastewater.

None of these releases are considered to be a significant source of contamination of the soil compartment. Similarly, the fraction emitted to air is not expected to have an action of environmental relevance on the air concentration, due to air instant dilution.

Table 4.3-18: Environmental compartments potentially exposed relative to the use of outdoor diffusers

Main scenario	Sub-scenario	Environmental compartments					Secondary poisoning
		Air	STP/ rainwater	Soil	Surface water	Ground water	
Diffuser	All (rural/urban)	(+)		(+)			+

++ Compartment primarily exposed (soil, STP)

+ Compartment secondarily exposed (surface water from STP discharge, agricultural soil from sludge application, groundwater further to soil exposure)

(+) Compartment potentially exposed

Therefore, no priority was given to develop a scenario for these applications.

Powders, granules

- Powder, Tracking powder

Powders are often used outside to control ants around buildings. It is usually recommended to apply the powder directly on nest entrances or on insect pathways. It is also advised to spray the product on walls/floor junctions.

Powders can be applied directly by powdering or by means of either dust or liquid sprayers. In the latter, the solvent acts as vector to facilitate the application and is rapidly evaporated. Some products are also solubilized and applied using a watering can. In the case of dust or liquid sprays, the scenario to be applied is the scenario developed in chapter 4.3 for spray application around the building. It is expected that direct powdering on nest would lead to more limited releases than spray application and should be considered as spot application on soil. In this case, the possible receiving compartments are the soil and to a lesser extent, the air. Release to the air is considered negligible. It is not current practice to collect unconsumed product. Therefore, it is considered that the fraction released during powder application to the environment is 90%, either directly or through ultimate releases after target insect death.

$$F_{spot,powder} = 0.9$$

Releases to air are considered to be negligible.

Table 4.3-19: Environmental compartments potentially exposed relative to the use of powder on ant nests

Main scenario	Sub-scenario	Environmental compartments/protected target exposed					Secondary poisoning
		Air	STP/ rainwater	Soil	Surface water	Ground water	
Powder	Ant nest (rural/urban)	(+)		++		+	+

++ Compartment primarily exposed (soil, STP)

+ Compartment secondarily exposed (surface water from STP discharge, agricultural soil from sludge application, groundwater further to soil exposure)

(+) Compartment potentially exposed

- Granules

The use pattern of granules is basically similar to that of powders. As above, granules may be used either directly or dissolved prior application. However, it should be noticed that they might be used against flying insects (flies and to a lesser extent to mosquitoes). For this use, granules are placed in a recipient so that no release to the environment is expected.

- Powdering of wasp nest

Answers to the survey performed in order to establish the present scenario as regards outdoor powder applications indicate that powders may be applied to control wasps using pressurised dust applicator or powder spray. Powder acts by contact. Uses are limited to professional applicators. About 15-30 mg of product are used per application. No specific scenario is developed for this application. It is recommended to adapt the scenario described in sections 4.3 and 4.4.4 for the treatment by spray of wasp and hornet's nest.

4.3.4.2 Emission factors and size of the receiving compartment

Summary of the emission factors

Emission factors to be used for the calculation of the emissions during outdoor spot applications are summarised in Table 4.3-20.

Table 4.3-20: Default values for emission factor in treated surfaces during outdoor spot applications

Variable/parameter	Symbol	Unit	Default	S/D/O/P
Application				
Fraction emitted during outdoor gel application	$F_{spot,gel}$	-	0.9	D
Fraction emitted during outdoor bait application	$F_{spot,bait}$	-	0.2	D
Fraction emitted to soil during outdoor powder application on ant nest	$F_{spot,powder}$	-	0.9	D

Size of the receiving compartment

Due to the variety of application methods, no default values for the receiving compartment are defined for outdoor spot applications. However, general guidance is provided to allow the calculation of the size of the treated zone and the size of the receiving compartment.

For spot applications, the receiving compartment will have to be defined in view of the specification of the label, including width of the band of application, size of the bait box, etc... Its size will be a function of the size of the treated zone. It should be defined as a 50-cm area around the treated area (Area directly exposed to insecticide: $AREA_{exposed}$) with a depth of 50-cm ($DEPTH_{soil}$).

In order to simplify the calculations, it can be assumed that the receiving compartment is a cube with dimension of 0.5 x 0.5 x 0.5 m.

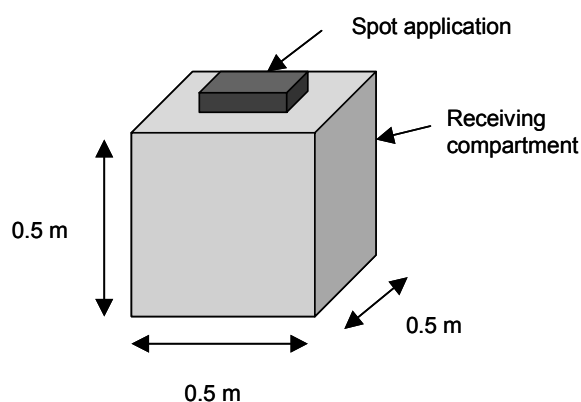

Figure 4.3-6: example of receiving compartment for spot application

The average size of the terrace can be used in order to define the number of spot treated per house (N_{sites}) e.g. for bait station using the recommended distance between bait station and/or the recommended application rate.

Such information is not available for larger public or industrial buildings, and data from house will have to be extrapolated.

The indirectly exposed area ($AREA_{\text{exposed_ind}}$) corresponds to the terrace area or the garden area.

4.4 Emission models for outdoor scenarios

In this chapter, models are provided to calculate emission to the environment and concentration in the receiving compartment at a local scale only. This approach was commonly acknowledged for other biocides products so far, such as in the ESD for wood preservatives (OECD 2003) or in the ESD for insecticides used in stable and manures (OECD 2005). It has also been common practice in the European Union for biocides hitherto. From a practical point of view, it was decided that the subscripts “local” as opposite to “reg” for regional emissions recommended by (Van der Poel 2000) will not be used in this ESD in order to simplify the text: Therefore, except if otherwise stated, emissions and concentrations are meant to be “local”.

The following chapter contains:

- Generic emission model for mixing/loading step (page 135)
- Emission model for spray application: Treatment around the building (page 136). In this section, details are provided for the calculation of emission during the application and during further wash-off by rainfall when insecticides are applied for the control of flying insects or for the control of crawling insects. Indications are also given for the use of these emission values to derive local concentrations either in urban area or in countryside.
- Emission model for outdoor spray application in crawling space (page 144).
- Emission model for outdoor spray application on wasp or hornet nest (page 146).
- Emission model for spot application (page 146).
- Emission model to conduct exposure assessment related to secondary poisoning (page 146).

The amount of treated facility per day per watershed is not known. For the scenario in urban area, it is proposed to consider an STP catchment of 10 000 inhabitants. This figure is the default value proposed by the Technical Guidance Document (E.C. 2003) corresponding to European conditions. A simultaneity factor has been defined in section 2.7. It has been adapted for outdoor uses and set to $F_{\text{simultaneity}} = 0.03$.

The default number of houses per STP catchment is 4,000.

These provisional figures need further refinement and have to be adapted to national or regional conditions.

In this section, removal processes from the receiving compartment, such as degradation or volatilisation are not taken into account.

4.4.1 Mixing/loading step

- Emission to soil:

$$E_{prep,soil} = Q_{prod,prep} \times F_{AI} \times N_{prep} \times F_{prep,soil} \times 10^{-3} \quad (39)$$

Variable/parameter (units)	Symbol	Unit	Default	S/D/O/P
Input:				
Quantity of product used for one preparation event	$Q_{prod,prep}$	g	-	S
Fraction of active substance in the commercial product	F_{AI}	-	-	S
Number of preparations per day <i>For both non professional and professional</i>	N_{prep}	d ⁻¹	3	D/S
Fraction emitted to soil during preparation step [-]	$F_{prep,soil}$	-	Table 3.2-33.2-3 and Table 3.2-43.2-4	P
Soil volume for the mixing loading step	$V_{prep,soil}$	m ³	0.40	D
Bulk density of wet soil	RHO_{soil}	kg _{-ww} .m ⁻³	1,700	D
Output:				
Emission to soil during preparation step	$E_{prep,soil}$	kg.d ⁻¹	-	O
Local concentration of active substance in soil during mixing/loading	$C_{prep,soil}$	kg.kgww ⁻¹ .d-1		O

The number of preparation per day is not considered differently for professional or general public. Emissions are estimated at the local scale, *i.e.* at house or public/professional building scale. The volume to be prepared and the number of preparations is a function of the surface treated – per building- and independent of the applicator. It is acknowledged that the general public may use material of lower capacity than professionals and that the sprayer may be refilled more frequently. On the other hand, professionals may use high capacity sprayers allowing for the complete treatment of the building with only one tank filling operation. Therefore, it proposed to use the following values, as described in section 1.1.

→ $N_{prep} = 1$ (d⁻¹) for private houses; 3 (d⁻¹) for larger buildings

Ideally, the number of preparation per day should be calculated as a function of the quantity of preparations needed for the default surface treated, based on the worst case assumption that a 5L sprayer is used.

In the present document, it is considered that the preparation step does not take place in the treated area. Concentrations in soil are calculated distinctly from the application step. The local concentration of the substance in the soil can be calculated for the countryside:

$$C_{prep,soil} = \frac{E_{prep,soil}}{V_{prep,soil} \times RHO_{soil}} \quad (40)$$

In urban areas, releases from the preparation step to the ground are washed up by rainwater. Emissions from applications and emissions from preparation should be added to give a total 'per-application' loading to wastewater. This loading should then be adjusted to take into account the maximum number of sources that may contribute to wastewater on one day in a typical Sewage Treatment Plant catchment.

4.4.2 Spray application: Treatment around the building

Two default scenarios are considered:

- For flying insects, the treatment of the whole surface of the walls is performed.
- For crawling insects, a perimeter treatment might be sufficient, *i.e.* the foundations of the structure and a band of soil around the building.

Generic scenarios are proposed for these two application modes, and they aim to cover a large range of actual application practices (*i.e.* a large variety of sprayers, of target organisms...). Therefore, where specific data on the application pattern are available, the surface treated should be recalculated according to the label or material technical data sheet (*e.g.* walls only or soil only, different width of treated area...).

According to the results of the survey performed prior to drafting this scenario and to the technical notice of commercially available insecticide formulations, several applications by spray may have to be performed on the same building, the interval between applications ranging from one to several weeks. In some countries, in order to achieve long-term control, some pest control companies offer monthly perimeter spray programs (Klotz 2005). On the same day, it is however unlikely that more than one application on a building has to be performed.

The emission models proposed in this section are made for a single application. If the recommended use implies repeated applications, then it must be further considered in the exposure assessment.

In the countryside, emissions from repeated applications will tend to increase the concentrations due to the first application and have to be added, as releases to the soil of further applications around the building. In a first tier assessment, emissions from different applications should be summed up. In a refined exposure assessment, degradation and dissipation between applications would have to be taken into account.

In urban areas, releases and thus concentration in water are calculated on a daily basis, and no local accumulation is expected. Application can therefore be considered separately.

As explained previously, in rural area where local concentrations are derived, it may not be relevant to calculate the risk for non-target arthropods species in the treated area just after the application but it may be necessary to protect other species in this area. It is therefore proposed to calculate as 1st Tier emissions in the treated area after application. In addition, considerations should be given to the emission in the adjacent untreated zone after application and in the treated zone 30 days after application.

4.4.2.1 Emission scenario for flying insects

Application step

Local emissions related to the outdoor application of insecticide on the entire wall for flying insect treatment are derived from the following model calculation:

$$E_{\text{spray,wall,appl,soil}} = Q_{\text{prod}} \times F_{\text{AI}} \times \text{AREA}_{\text{wall}} \times F_{\text{spray,wall}} \quad (41)$$

It is reminded that if application on soil is part of the uses claimed, the model should be adapted.

Variable/parameter (units)	Symbol	Unit	Default	S/D/O/P
Input:				
Quantity of product applied	Q_{prod}	kg.m ⁻²	-	S
Fraction of active substance in the commercial product	F_{AI}	[-]	-	S
Area of exterior wall treated per day	$\text{AREA}_{\text{wall}}$	m ² .d ⁻¹		
- private house			125	P
- public/industrial building ¹			625	
Fraction emitted to soil during outdoor wall spray application against flying insects	$F_{\text{spray,wall}}$	[-]	0.3	D
Soil volume around building (flying insects)	$V_{\text{spray,soil}}$	m ³		P
- private house			13	
- public, commercial or industrial building ¹			63	
Bulk density of wet soil	RHO_{soil}	kg _{-ww} .m ⁻³	1,700	D
Output:				
Local emission from outdoor spray application on wall due to deposition on soil	$E_{\text{spray,wall,appl,soil}}$	kg.d ⁻¹		O
Local concentration of active ingredient in soil adjacent to the house due to wall application against flying insects	$C_{\text{spray,wall,appl,soil}}$	kg.kgww ⁻¹		O

¹ Provisional data (5th meeting of the OECD Task force on biocides)

Wash-off of the treated surfaces by rainfall

Local emissions related to the washing by rainwater of the entire wall are derived from the following model calculation:

$$E_{\text{spray,wall wash-off,soil}} = Q_{\text{prod}} \times F_{\text{AI}} \times \text{AREA}_{\text{wall}} \times F_{\text{spray,wash-off}} \quad (42)$$

Variable/parameter (units)	Symbol	Unit	Default	S/D/O/P
Input:				
Quantity of product applied	Q_{prod}	kg.m ⁻²	-	S
Fraction of active substance in the commercial product	F_{AI}	-	-	S
Area of exterior wall treated per day	$\text{AREA}_{\text{wall}}$	m ² .d ⁻¹		
- private house			125	P
- public/industrial building ¹			625	
Fraction emitted to soil due to wash-off by rainfall	$F_{\text{spray,wash-off}}$	-	0.5	D
Soil volume around building (flying insects)	$V_{\text{spray,soil}}$	m ³		
- private house			13	D
- - public, commercial or industrial building ¹			63	
Output:				
Local emission from outdoor spray application on wall due to wash-off by rainfall	$E_{\text{spray,wall,wash-off,soil}}$	kg.d ⁻¹		O
Local concentration of active ingredient in soil adjacent to the house due to wash-off by rainfall	$C_{\text{spray,wall,wash-off,soil}}$	kg.kgww ⁻¹		O
Local concentration of active ingredient in soil adjacent to the house due to washing and wall application for flying insects	$C_{\text{spray,flying,soil}}$	kg.kgww ⁻¹		O

¹ Provisional data (5th meeting of the OECD Task force on biocides)

Summary of emissions in urban and rural environments

- Urban environments

In urban areas, releases to hard surfaces are directed to the rainwater/sewage system during the first rain event following application. Rainfall will then wash-off both quantities emitted to soil during application and from wall from wash-off. Emissions are calculated as follow:

$$E_{\text{spray, flying}} = E_{\text{spraying wall, soil}} + E_{\text{spray, wall, wash-off-soil}} \quad (43)$$

Variable/parameter (units)	Symbol	Unit	Default	S/D/O/P
Output: Local emission from outdoor spray application on wall due to wall application and wash-off by rainfall	$E_{\text{spray, flying}}$	kg.d ⁻¹		O

These emission rates, expressed in kg.d⁻¹, can then be used further in exposure assessment as input values in sewage treatment models or surface water models. These kinds of models are an integral part of all national risk assessment schemes and need not to be mentioned here. For the European conditions, it is proposed to provisionally assume a city of 10 000 inhabitants in which up to 120 houses are treated per day for the “private house scenario”, *i.e.* that the emissions have to be multiplied by 120 at the STP level. This number is derived from an average number of 4,000 houses per STP catchment and a simultaneity factor of 0.0275 (see section 2.7).

- Rural area

The local concentration of the active substance in soil in the countryside due to wall application can be calculated using the following equation:

$$C_{\text{spraying wall, soil}} = \frac{E_{\text{spraying wall, soil}}}{V_{\text{spray, soil}} \times RHO_{\text{soil}}} \quad (44)$$

with $E_{\text{spraying wall, soil}}$, $V_{\text{spray, soil}}$ and RHO_{soil} (see p137)

The local concentration of the active substance in soil in the countryside due to wash-off by rainfall can be calculated from the following model calculation.

$$C_{\text{spray, wall, wash-off, soil}} = \frac{E_{\text{spray wall, wash-off}}}{V_{\text{spray, soil}} \times RHO_{\text{soil}}} \quad (45)$$

These emissions have to be added to the residual concentration from application.

If no removal processes are taken into account between the two events, the total concentration in soil can be calculated as:

$$C_{\text{spray, flying, total}} = \frac{E_{\text{spray, wall}} + E_{\text{spray, wall, wash-off}}}{V_{\text{spray, soil}} \times RHO_{\text{soil}}} \quad (46)$$

4.4.2.2 Emission scenario for crawling insects

Application step

Local emissions related to the outdoor spray application of insecticide on the foundations and on the soil around the house (e.g. for crawling insect treatment) are derived from the following model calculation:

$$E_{\text{spray, foundation}} = Q_{\text{prod}} \times F_{\text{AI}} \times \text{AREA}_{\text{foundation}} \times F_{\text{spray, foundation}} \quad (47)$$

$$E_{\text{spray, soil}} = \text{AREA}_{\text{soil}} \times Q_{\text{prod}} \times F_{\text{AI}} \times F_{\text{spray, soil}} \quad (48)$$

$$E_{\text{spray, untreated soil}} = Q_{\text{prod}} \times F_{\text{AI}} \times F_{\text{spray, untreated soil}} \times \text{AREA}_{\text{untreated}} \quad (49)$$

Variable/parameter (units)	Symbol	Unit	Default	S/D/O/P
Input:				
Quantity of product applied	Q_{prod}	kg.m ⁻²	-	S
Fraction of active substance in the commercial product	F_{AI}	-	-	S
Area of foundation treated per day - private house - public/commercial/industrial building ¹	$\text{AREA}_{\text{foundation}}$	m ² .d ⁻¹	25 125	P
Area of soil treated per day - private house - public/commercial/industrial building ¹	$\text{AREA}_{\text{soil}}$	m ² .d ⁻¹	26 126	P
Fraction emitted to soil during outdoor foundation spray application against crawling insects	$F_{\text{spray, foundation}}$	-	0.3	D
Fraction emitted to soil during outdoor ground spray application - treated zone - untreated zone	$F_{\text{spray, soil}}$ $F_{\text{spray, untreated soil}}$	-	0.99 0.0042	P
Area of untreated zone - private house - public/commercial/industrial building ¹	$\text{AREA}_{\text{untreated}}$	m ² .d ⁻¹	28 128	P
Soil volume for deposition and application at 0.5 m (treated) - private house - public/industrial building ¹	$V_{\text{spray, treated soil}}$	m ³	13 63	P
Soil volume for deposition and application (untreated) - private house - public/commercial/industrial building ¹	$V_{\text{spray, untreated soil}}$	m ³	14 64	P

Variable/parameter (units)	Symbol	Unit	Default	S/D/O/P
Bulk density of wet soil	RHO_{soil}	$kg_{-}ww \cdot m^{-3}$	1,700	D
Output:				
Emission from outdoor spray application on foundations against crawling insects	$E_{spray, foundation}$	$kg \cdot d^{-1}$		O
Emission from outdoor spray application on soil	$E_{spray, soil}$	$kg \cdot d^{-1}$		O
Emission from outdoor spray application on soil in untreated area	$E_{spray, untreated soil}$	$kg \cdot d^{-1}$		
Concentration of active ingredient in treated soil at 0.5m from the house due to foundation and ground application against crawling insects	$C_{spray, treated soil}$	$kg \cdot kgww^{-1}$		O
Concentration of active ingredient in untreated soil due to foundation and ground application against crawling insects	$C_{spray, untreated soil}$	$kg \cdot kgww^{-1}$		O

¹ Provisional data (5th meeting of the OECD Task force on biocides)

Wash-off of the treated surface by rainfall

Local emissions related to the wash-off by rainwater of the foundations are derived from the following model calculation:

$$E_{\text{spray, foundation, wash-off}} = \text{AREA}_{\text{foundation}} \times Q_{\text{prod}} \times F_{\text{AI}} \times F_{\text{spray, wash-off}} \quad (50)$$

Variable/parameter (units)	Symbol	Unit	Default	S/D/O/P
Input:				
Quantity of product applied	Q_{prod}	kg.m ⁻²	-	S
Fraction of active substance in the commercial product	F_{AI}	-	-	S
Area of foundation treated per day - private house - public/commercial/industrial building ¹	$\text{AREA}_{\text{foundation}}$	m ² .d ⁻¹	25 125	P
Fraction emitted to soil due to washing from rainwater	$F_{\text{spray, wash-off}}$	-	0.5	D
Soil volume for wash-off at 0.5 m (treated) - private house - public/commercial/industrial building ¹	$V_{\text{spray, treatedsoil}}$	m ³	13 63	D
Bulk density of wet soil	RHO_{soil}	kg _{-ww} .m ⁻³	1,700	D
Output:				
Local emission from outdoor spray application on foundation due to washing	$E_{\text{spray, foundation, wash-off}}$	kg.d ⁻¹		O

¹ Provisional data (5th meeting of the OECD Task force on biocides)

These emissions have to be added to the residual concentration from application.

Summary of emissions in urban and rural environments

- Urban area

In urban areas, releases to hard surfaces are directed to the storm water system during the first rain event following application. Rainfall will then wash-off both quantities emitted to soil during application and from foundation from wash-off. Emissions are calculated as follow:

$$E_{\text{spray, crawlinginsects}} = E_{\text{spray, foundation}} + E_{\text{spray, soil}} + E_{\text{spray, foundation, wash-off}} \quad (51)$$

These emission rates expressed in kg.d⁻¹ can then be used further in exposure assessment as input values in sewage treatment models or surface water models.

These kinds of models are an integral part of all national risk assessment schemes and need not to be mentioned here.

For the European conditions, it is proposed to provisionally assume a city of 10 000 inhabitants in which up to 120 houses are treated per day for the “private house scenario”, *i.e.* that the emissions have to be multiplied by 120 at the STP level. This number is derived from an average number of 4,000 houses per STP catchment and a simultaneity factor of 0.0275 (see section 2.7).

- Rural area

It is proposed to calculate two local concentrations of active substance in soil in the countryside, depending of the level of protection sought.

As indicated previously, it is expected that a risk might arise in the treated zone following the application of pesticide. Additional consideration should be given to the possible potential for recovery /recolonisation of non-target populations from the surfaces adjacent to the treated area. Potential for recovery /recolonisation of non-target species will be achievable only if:

- the population in the adjacent zone remain unaffected;
- the effects of the product are not persistent to allow the return of the organisms.

However, the regulator may want to protect non-target organisms and therefore, models are provided in order to calculate concentration in the treated area. Indications are also provided to calculate predicted local concentrations in the untreated area.

- Treated area

Concentrations are calculated in the soil volume distant of 0.5 m from the wall, which receive deposition, run-off and direct application (see Figure 4.4-14.4-1).

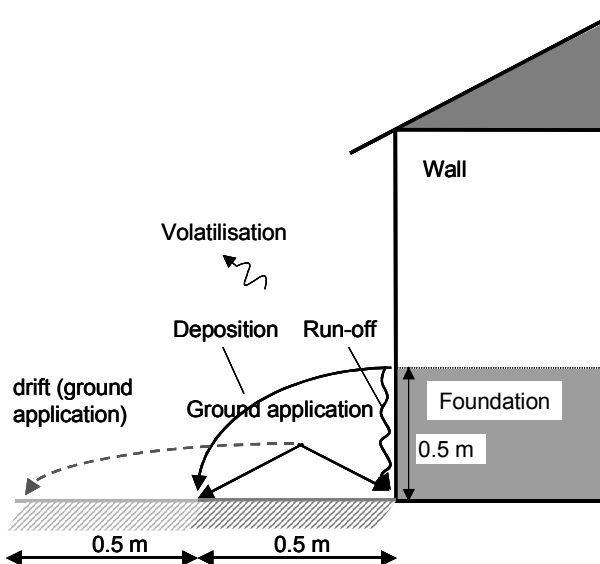

Figure 4.4-1: Zone of direct application, deposition and run-off and untreated zone exposed to drift from ground application (crawling insects)

The emissions to ground due to direct application or to run-off and deposition are considered to be homogenous on the ground surface.

The local concentration of the active substance in soil in the countryside can be calculated from the following model calculation.

- Treated area

$$C_{\text{spray,treated soil}} = \frac{E_{\text{spray,foundation}} + E_{\text{spray,soil}} + E_{\text{spray,foundation,wash-off}}}{V_{\text{spray,treatedsoil}} \times \text{RHO}_{\text{soil}}} \quad (52)$$

- Untreated area

$$C_{\text{spray,untreated soil}} = \frac{E_{\text{spray,untreatedsoil}}}{V_{\text{spray,untreatedsoil}} \times \text{RHO}_{\text{soil}}} \quad (53)$$

4.4.3 Spray application: crawling space application

Local emission related to the treatment of crawling space under building by spray application is derived from the following model calculation:

$$E_{\text{crawling,soil}} = Q_{\text{prod}} \times F_{\text{AI}} \times (\text{AREA}_{\text{crawling}} \times F_{\text{spray,wall-ceiling}} + \text{AREA}_{\text{house}} \times F_{\text{spray,soil}}) \quad (54)$$

Variable/parameter (units)	Symbol	Unit	Default	S/D/O/P
Input:				
Quantity of product applied	Q_{prod}	kg.m ⁻²	-	S
Fraction of active substance in the commercial product	F_{AI}	-	-	S
Area of walls and ceiling (crawling space) treated per day	$AREA_{crawling}$	m ² .d ⁻¹		
- private house			156	D
- public/commercial/industrial building			-	S
Area of soil (crawling space) treated per day	$AREA_{house}$	m ² .d ⁻¹		
- private house			131	P
- public/commercial/industrial building			-	S
Fraction emitted to soil during crawling space spray application on walls and ceiling	$F_{spray, wall-ceiling}$	-	0.3	D
Fraction emitted to soil during crawling space spray application on soil	$F_{spray, soil}$	-	1	D
Soil volume for deposition and application	$V_{spray, treatedsoil}$	m ³		
- private house			66	P
- public/commercial/industrial building			-	S
Bulk density of wet soil	RHO_{soil}	kg.ww.m ⁻³	1,700	D
Output:				
Emission from crawling space spray application on soil	$E_{crawling, soil}$	kg.d ⁻¹		O
Concentration of active ingredient in soil	$C_{crawling, soil}$	kg.kgww ⁻¹		O

Concentrations in soil under the building can be calculated as follows:

$$C_{crawling, soil} = \frac{E_{crawling, soil}}{V_{spray, treatedsoil} \times RHO_{soil}} \quad (55)$$

4.4.4 Spray application: Outdoor nest spray application

Variable/parameter (units)	Symbol	Unit	Default	S/D/O/P
Input:				
Quantity of commercial product applied per nest	Q_{prod}	kg	-	S
Fraction of active substance in the commercial product	F_{AI}	-	-	S
Fraction emitted to soil during nest spray due to deposition	$F_{\text{spray, nest, deposition}}$	-	0.3	D
Soil volume for deposition and application at 3 m from the nest	$V_{\text{spray, nest, soil}}$	m^3	0.1	D
Bulk density of wet soil	RHO_{soil}	$\frac{\text{kg} \cdot \text{ww}}{\text{m}^3}$	1,700	D
Output:				
Emission to soil during nest spray application	$E_{\text{spray, nest, soil}}$	$\text{kg} \cdot \text{d}^{-1}$		O
Concentration of active ingredient in soil	$C_{\text{spray, nest, soil}}$	$\frac{\text{kg} \cdot \text{kgw}}{\text{w}^{-1}}$		O

Local emission related to the treatment of wasp or hornet nests for one spray application is derived from the following model calculation:

$$E_{\text{spray, nest, soil}} = Q_{\text{prod}} \times F_{\text{AI}} \times F_{\text{spray, nest, deposition}} \quad (56)$$

If more than one application is anticipated to the same nest, then the emissions from different applications have to be added.

The local concentration of the active substance in soil resulting of the nest spray application step in the countryside can be calculated from the following model calculation:

$$C_{\text{spray, nest, soil}} = \frac{E_{\text{spray, nest, soil}}}{V_{\text{spray, nest, soil}} \times \text{RHO}_{\text{soil}}} \quad (57)$$

4.4.5 Spot application

Since the use patterns are comparable, it is proposed to use an adaptation of the scenario developed in the framework of the EU Biocides Directive for the assessment of exposure to rodenticides in bait boxes (Larsen 2003). The number of application (N_{appl}) has to be considered if the product is applied on spot location on e.g. terrace and that the soil is the receiving compartment. Otherwise, N_{appl} has to be set to 1.

The equations for local releases to air and to soil during spot application would be:

$$E_{\text{spot, soil}} = Q_{\text{prod}} \times F_{\text{AI}} \times N_{\text{sites}} \times N_{\text{appl}} \times F_{\text{spot, soil}} \quad (58)$$

$$F_{\text{spot, soil}} \text{ can be equal to } F_{\text{spot, gel}}, F_{\text{spot, bait}}, \text{ or } F_{\text{outdoor, nest powder, soil}} \quad (59)$$

Variable/parameter	Symbol	Unit	Default	S/D/O/P
Input				
Amount of product used at each refilling in the control operation for each bait box	Q_{prod}	g	-	S
Fraction of active substance in product	F_{AI}	[-]	-	S
Number of application sites	N_{sites}	[-]	-	S
Number of application	N_{appl}	[-]	-	S
Fraction emitted to STP during outdoor gel application	$F_{\text{spot, gel}}$	-	0.9	D
Fraction emitted to STP during outdoor bait application	$F_{\text{spot, bait}}$	-	0.2	D
Fraction emitted to soil during outdoor powder application on ant nest	$F_{\text{outdoor, nest powder, soil}}$	-	0.9	D
Output				
Direct emission rate of active substance to soil from a campaign	$E_{\text{spot, soil}}$	g		O

Concentrations in the soil around the spot application after direct release can be estimated by the equation:

$$C_{\text{spot, soil}} = \frac{E_{\text{spot, soil}}}{\text{AREA}_{\text{exposed}} \times \text{DEPTH}_{\text{soil}} \times \text{RHO}_{\text{soil}}} \quad (60)$$

Variable/parameter	Symbol	Unit	Default	S/D/O/P
Input				
Local direct emission rate of active substance to soil	$E_{\text{spot,soil}}$	g		D
Area directly exposed to insecticide - Single point of release - Other	$AREA_{\text{exposed}}$	m ²	0.25 -	D/S
Depth of exposed soil	$DEPTH_{\text{soil}}$	m	0.5	D
Volume of soil exposed - Single point of release - Other	$VOLUME_{\text{soil}}$	m ³	0.125 -	
Number of application sites	N_{sites}	[-]		S
Density of exposed soil RHO	RHO_{soil}	kg.m ⁻³	1,700	D
Output				
Local concentration in soil due to direct release after a campaign ¹⁾	$C_{\text{spot,soil}}$	mg.kg ⁻¹		0

1) Around the treated spot

Chapter 5 Exposure scenarios for secondary poisoning to wild birds and mammals

5.1 Introduction

In general, secondary poisoning relates to toxic effects occurring in higher levels of food chains, either in the aquatic or terrestrial environment, which result from ingestion of organisms from lower trophic levels that contain accumulated substances. The scenario for secondary poisoning is also called an “indirect exposure scenario” whereas a “direct exposure” corresponds to primary poisoning. In this report, the term secondary poisoning is used. It relates to the potential exposure of vertebrates (*i.e.* birds or mammals) consuming contaminated insects or taking their food, *e.g.* grass or seeds, in the treated area. The risk of secondary poisoning is considered at the local scale, *i.e.* building scale. This approach is slightly different from that developed, for instance in the EU TGD (E.C. 2003) where the risk of secondary poisoning reflect the risk of accumulation along the food chain from diffuse exposure.

Primary poisoning, *i.e.* the direct consumption of insecticide by birds or mammals may mainly occur in the following cases:

- insecticides are applied together with food attractant, or
- Insecticides are applied as granular formulation.

It is not believed that powder, gels or any other sort of insecticides are in a form that could be sufficiently appetent to bird or mammals so they would be at risk.

Existing scenario are available for a similar type of exposure of bird and mammals and can easily be adapted for primary poisoning:

- For the insecticides applied with food attractants, the situation is similar to the use of rodenticide baits. Therefore, the approaches developed in Chapter 3 of the emission scenario document for biocides used as rodenticides (Ref. ENV.C3/SER/2001/0058) should be considered as reference.
- For granular insecticides, if granules are based on an organic carrier having a nutritional value then they may be taken up as food by birds and mammals. In such cases exposure can also be assessed in a similar way as for rodenticide baits. It has been pointed out that some granular insecticides made of carriers have no nutritional value for birds and mammals. Due to the practice, for bird to absorb granular inorganic particle (gizzard) the risk of consumption cannot however be discarded.

This scenario covers all releases resulting from outdoor surfaces treatments during the mixing/loading step, application step and washing by rainwater. Therefore all possible emission routes to soil *i.e.* by direct application, deposition of spray droplets, run-off and wash-off from vertical surfaces, will be taken into account for the calculations of the insecticide substances concentrations in soil, vegetation and animals. This scenario is primarily developed for spray application around the building which represents the worst case. It has to be adapted for other applications such as spot application.

As a reminder, in Chapter 4, two default scenarios have been considered for the outdoor application by spraying: the first concerns flying insects with a complete treatment of the whole surface of the walls in addition to a treatment of the band of soil around the building; the second concerns crawling insects with a perimeter treatment (“foundation”) of the structure and a band of soil around the building.

Otherwise, it is proposed to consider two time scales, which are acute and short-term exposure; long-term exposure are not thought to be relevant for biocides used as insecticides spray on outside surfaces of buildings. Acute exposure occurs immediately after the application: animals fetching their food in the treated area will be exposed to residues from direct application on ground and deposition and run-off from

the treated wall/foundation (see 4.4.2.1 and 4.4.2.2). Short-term exposure corresponds to the additional releases due to further washing of the wall/foundation by rainwater (see section 4.3.1.6).

The exposure models presented here for evaluating the risk of secondary poisoning to non-target animals are adapted from existing models including the EU TGD (E.C. 2003) and guidance document (SANCO/4145 2002), to the outdoor uses of household insecticide.

The general rules for assessment of secondary poisoning are presented in Section 3.8 of the EU technical document (E.C. 2003). In addition, EU guidance document (SANCO/4145 2002) provides specific support to evaluate the exposure of birds and mammals to agricultural pesticides. For spray application of household and professional insecticides, the approach retained is relatively similar and parts of these two documents are reproduced here, including however specificities for household insecticides. Since almost only calculations from the original guidance documents are provided here, it is recommended to refer to these texts for further explanations.

A tiered approach is proposed: Tier 1 involves standard scenarios and default values; it represents a worst-case exposure assessment, which reflects a situation where the total daily feed is contaminated. The Tier 2 corresponds to refinement options and may be considered when a potential risk is indicated in tier 1.

5.2 First tier exposure assessment: general approach and calculation of the estimated theoretical exposition (ETE)

During the outdoor use of household or professional insecticides, the most important route of exposition is the intake of contaminated feed. Non-target animals have potentially a risk of secondary poisoning in three principal ways:

- 1/ by consumption of worms from contaminated soil
- 2/ by consumption of contaminated vegetation
- 3/ and through eating treated insects that have accumulated the poison.

Therefore, herbivorous, insectivorous and earthworms-eating animals are most at risk to be accidentally poisoned and these three types of dietary food are highly represented among mammals and birds.

Since this scenario was adapted from (SANCO/4145 2002), the “estimated theoretical exposure” (ETE) is used instead of the usual term PEC_{oral} . ETE corresponds to the PEC_{oral} per day. The risk is assessed as the ratio between the estimated daily intake (ETE) and the predicted no-effect concentration for oral intake for the non-target organism ($PNEC_{oral}$). Methods to derive $PNEC_{oral}$ are presented, for instance, in the EU TGD (E.C. 2003).

In the tier-1 assessment standardised worst-case scenarios are considered and ETE will be calculated on the basis of generic scenarios which consider:

- indicator species among mammals and birds for different crop categories (SANCO/4145 2002)
- residues in food as determined by (Fletcher *et al.* 1994) as a function of the treated crop.
- ETE is species-dependent: interspecific variations are due to differences in their normal diets, feeding habits, ecological or others factors.

5.2.1 Residues in food

As mentioned above, during the utilisation of household and professional insecticide, birds and mammals may be poisoned through the ingestion of contaminated insects, earthworms or vegetation resulting from the spray application of insecticide.

The theoretical exposure of vertebrates will then be a function of the estimated concentration of insecticide found in food sources of either herbivorous or insectivorous birds and mammals. Concentrations in plants and insects will be derived from the exposure scenario established for plant protection products in EU (SANCO/4145 2002) whereas concentrations in earthworms will be calculated according to EU TGD for chemicals and biocidal product (E.C. 2003).

Regarding herbivorous species, the contaminated vegetation is the garden or lawn around the treated building. A cartography of the typical garden was established for the French garden (UPJ 2005) and for the German garden (Vosswinkel *et al.* 2003) as described on Figure 5.2-15.2-4. The potential vegetation exposed can be represented by two plant categories: short-grass and leafy plant (*e.g.* clover, alfalfa, daisy family), which, according to (SANCO/4145 2002), are included in "Grassland" category and "leafy crops" category, respectively.

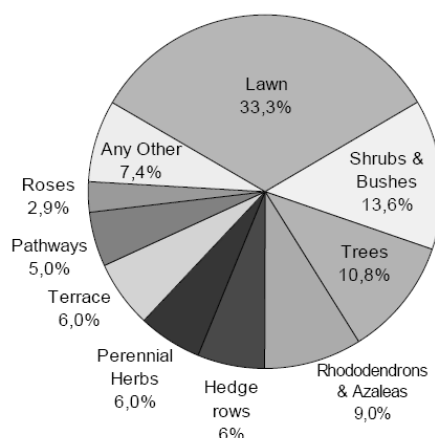

Figure 5.2-1: Ornamental garden plan (500m²) from (Vosswinkel *et al.* 2003)

5.2.2 Identification of representative species

In the scenario developed for plant protection products in the EU (SANCO/4145 2002), generic indicator species have been determined specifically for agricultural landscapes. Concerning the use of insecticides in the vicinity of inhabited areas, representative species that have the most of risk to be accidentally poisoned may be different than those defined for crops.

Therefore it is important to replace the generic indicators species defined for the crop categories with indicator species characteristic of the lawn/ garden (Table 4.2-1) such as tree sparrow, robin, black-billed Magpie, hedgehog, mole, badger, rabbit (instead of hare) and bat (pipistrelle). For the latter however, it should be noticed that bats are flying animals with a relatively large home range that feed almost exclusively on flying insects. Therefore, it is recommended that more information should be gathered on the biology of these species in order to confirm the relevance of the exposure. Small terrestrial insectivore mammals are considered as more relevant for the risk assessment.

It is proposed to include magpies as indicator species even if they are omnivorous because they are gregarious and live in close association with humans (Thomas 1994).

It should be noted that pets such as dogs and cats are also potentially at risk of being poisoned with insecticide by the consumption of grass in order to purge internal parasites or to assist in the removal of fur from the intestinal tract. However pets are carnivores and this phenomenon is supposed occasional and brief. The insecticide exposure to pets by consumption of contaminated vegetation is then assumed to be negligible and pets are not considered like relevant indicator species.

For the two time scales *i.e.* acute and short-term exposure, the same indicator species will be used.

Table 5.2-1: Indicator species representative of the lawn/garden and relevant for secondary poisoning

Indicator species	Example – species	Main food type/ category	Body weight
Small insectivorous mammal 1 ^(a)	Pipistrelle <i>Pipistrellus pipistrellus</i>	Large insects	7.6 g
Small insectivorous mammal 2 ^(b)	Shrew <i>Sorex araneus</i>	Large insects/ earthworms	10 g
Small insectivorous mammal 3 ^(a)	Mole <i>Talpa europaea</i>	Worms & slugs	85 g
Medium insectivorous mammal ^(a)	Hedgehog <i>Erinaceus europaeus</i>	Large insects/ Worms & slugs	1,100 g
Large insectivorous mammal ^(a)	Badger <i>Meles meles</i>	Large insects/ Worms & slugs	10,100 g
Small herbivorous mammal ^(c)	Vole - <i>Microtus arvalis</i>	Grasses	25 g
Medium herbivorous mammal ^(a)	Rabbit <i>Oryctolagus cuniculus</i>	Leafy plants	1,500 g
Small Insectivorous bird 1 ^(c)	Wren, <i>Troglodytes troglodytes</i> Tit - <i>Parus sp.</i>	Small insects	10 g
Small Insectivorous bird 2 ^(a)	Tree sparrow <i>Passer domesticus</i> robin <i>Erithacus rubecula</i>	Small insects	22 g
Medium Insectivorous bird ^(a)	Blackbird <i>Turdus merula</i>	Earthworms/ insects	113 g
Omnivorous bird ^(d)	Black-billed Magpie <i>Pica pica</i>	80% animal matter (insects, small mammals...)	225 g
Medium herbivorous bird ^(c)	Partridge <i>Perdix perdix</i> Pigeon <i>Columba livia domestica</i>	Leafy plants	300 g
Large herbivorous bird ^(c)	Goose - <i>Anser anser</i>	Short grasses	3,000 g

- (a) Indicator species assumed to be relevant for lawn/garden and not considered as indicator species in (SANCO/4145 2002). Data from (Crocker *et al.* 2002) except for black-billed magpie.
(b) Indicator species considered relevant for cereals crop in (SANCO/4145 2002)
(c) Data from (SANCO/4145 2002)
(d) Data from (Thomas 1994)

5.2.3 Estimated daily intake calculations

Basically, the estimated daily uptake is given by the following equation (SANCO/4145 2002):

$$ETE = C \times (FIR/bw) \times AV \times PT \times PD \quad (61)$$

Table 5.2-2: Parameters for the calculation of the daily intake (first tier exposure assessment)

Variable/parameter	Symbol	Unit
Concentration of substance in fresh diet	C	mg/kg
Food intake rate of indicator species	FIR	g fresh weight per day
Body weight	bw	g
Avoidance factor	AV	[-]
Fraction of diet obtained in treated area	PT	[-]
Fraction of food type in diet	PD	[-]

5.2.3.1 Concentration of substance in fresh diet (C), [mg/kg]

For the assessment of secondary poisoning via the consumption of contaminated worms, C corresponds to $C_{\text{earthworm}}$ and can be calculated according to the EU TGD part II section 3.8.3.7 and is not reproduced here.

For the assessment of secondary poisoning via the consumption of contaminated vegetation or insects, in line with document (SANCO/4145 2002), concentration (C) of active substance in contaminated vegetation or insects food can be estimated on the basis of generic data base of (Fletcher *et al.* 1994), (Fischer *et al.* 1997) and (Kenaga 1973) for vegetation, large insects and small insects respectively. These studies give residue concentrations of plant protection products on food for birds and mammals as a result of an application rate by spraying of 1 kg active substance per hectare (RUD = Residue per Unit Dose). Consequently, these figures have to be multiplied by the actual application rate (T_{appl}) to obtain the concentration per wet weight. Depending on the time scale either arithmetic means or 90th percentiles are used. RUD default values are described below.

$$C = RUD \times T_{\text{appl}} \times 10^{-4} \quad (62)$$

Table 5.2-3: Parameters for the calculation of the concentration of substance in fresh diet

Variable/parameter	Symbol	Unit
Concentration of substance in fresh diet	C	mg/kg
Residue per Unit Dose	RUD	mg.kg ⁻¹
Application rate	T_{appl}	kg/m ²

For household insecticides, the application rate is usually provided as kg/m². Therefore, an additional factor of 10⁻⁴ has to be added to convert T_{appl} into kg/ha.

Exposure of birds and mammals has to be calculated in the treated zone that may receive insecticide from both direct application on the ground and indirect emission from the treatment of walls/foundation after deposition or run-off (see section 4.3 for details).

- Acute exposure

Within this scenario three emission routes to soil are considered in acute exposure (direct application, deposition of spray droplets and run-off from wall). By considering default values of 0.1 and 0.2 for the fraction emitted to soil during outdoor wall spray application due to deposition and to run-off respectively, a 0.5-m height for foundation treatment or 2.5-m height for wall treatment, and assuming the same application rate on walls and soil, the total application rate (T_{appl}) should be calculated as follow.

Application rate (APPL) is function of the quantity of commercial product (Q_{prod}) and the fraction of active substance in the commercial product (F_{AI}) as follows:

$$\text{APPL} = Q_{\text{prod}} \times F_{\text{AI}} \quad (63)$$

- Wall treatment:

$$T_{\text{appl}} = (\text{APPL} \times 0.3) \times 2.5$$

$$\text{i.e. } T_{\text{appl}} = \text{APPL} \times 0.75 \quad (64)$$

- - Perimeter treatment:

$$T_{\text{appl}} = \text{APPL} \times 1 + (\text{APPL} \times 0.3) \times 0.5$$

$$\text{i.e. } T_{\text{appl}} = \text{APPL} \times 1.15 \quad (65)$$

- Short term exposure

In addition, additional releases may occur after application owing to the wash-off of the wall or foundation by rainwater. In line with the emission factors calculated in ESD for outdoor spray applications, 70% of the product applied remains on the surface of the wall immediately after application. In the first tier of exposure assessment, it is proposed that the totality of the product on the wall will be leached during the first rain event which occurs 3 days after application. This figure corresponds to a worst case. Therefore, in case of short term exposure a residue value of $\text{APPL}_{\text{ground}} \times 0.7$ ($=\text{APPL}_{\text{wash-off}}$) should be added and calculation of T_{appl} becomes:

- Wall treatment:

$$T_{\text{appl}} = (\text{APPL} \times 1) \times 2.5$$

$$\text{i.e. } T_{\text{appl}} = \text{APPL} \times 2.5 \quad (66)$$

- Perimeter treatment:

$$T_{\text{appl}} = \text{APPL} \times 1 + (\text{APPL} \times 1) \times 0.5$$

$$\text{i.e. } T_{\text{appl}} = \text{APPL} \times 1.5 \quad (67)$$

Table 5.2-4: Application rate calculation for wall and perimeter treatment

Variable/parameter (units)	Symbol	Unit	Default	S/D/O/P
Input:				
Quantity of commercial applied	Q_{prod}	kg.m ⁻²	-	S
Fraction of active substance in the commercial product	F_{AI}	-	-	S
Output:				
Application rate per square meter (ground)	APPL	kg.m ⁻²	-	O
Application rate of active substance	T_{appl}	kg.m ⁻²	-	O

5.2.3.2 Food intake rate of indicator species (FIR), [g/d]

The food intake rate default values are derived from an extensive review by (Crocker *et al.* 2002). Estimated values are based on means of daily energy expenditure for free-ranging animals and on the energy content, moisture and assimilation efficiencies of the different food types. Equations and tables are found in Appendix I of (SANCO/4145 2002) or in (Crocker *et al.* 2002). In Table 5.2-5, FIR are determined for indicators species considered as relevant for lawn/garden; for the others indicator species details on the different parameters to calculate FIR are reported in (SANCO/4145 2002).

Table 5.2-5: Food intake rate (FIR) for indicator species of lawn/garden with parameters referenced in (Crocker *et al.* 2002)

Indicator species	Daily Energy Expenditure ¹ (kJ/d)	Food characteristic ²			Assimilation efficiencies ³ (%)	FIR ⁴ (fresh materiel) (g/day)
		Food type	Energy (kJ/g dry wgt)	Moisture (%)		
Small insectivorous mammal 1 - Pipistrelle (7.6 g)	29.3	Arthropods	21.9	70.5	88	5.2
Small insectivorous mammal 3 – Mole (85 g)	160.9	Soil invertebrates	19.3	84.6	88	61.2
Medium insectivorous mammal – Hedgehog (1100 g)	978.6	Arthropods	21.9	70.5	88	172.1
		Soil invertebrates	19.3	84.6	88	374.2
Large insectivorous mammal – Badger (10100 g)	4673.1	Arthropods	21.9	70.5	88	822
		Soil invertebrates	19.3	84.6	88	1786.7
Medium herbivorous mammal – Rabbit (1500 g)	1217.9	Grasses, cereal shoots	18	76.4	74	387.4
Small Insectivorous bird 2 - Tree sparrow, robin (22 g)	88.4	Arthropods	21.9	70.5	76	18
Medium Insectivorous bird – Blackbird (113 g)	196.7	Soil invertebrates	19.3	84.6	76	87.1
Omnivorous bird - Black-billed Magpie (225 g)	453.8	Arthropods	21.9	70.5	76	92.4
		Soil invertebrates	19.3	84.6	76	200.9

1) DEE calculated from “other eutherians” equation and “passerine” equation for mammals and birds respectively (see Tables 1/2 in Crocker *et al.*, 2002)

2) values from Crocker *et al.* (2002) in Table 4

3) values from Crocker *et al.* (2002) in Tables 5/6

4) with $FIR = DEE / ((Energy\ in\ food \times (1 - Moisture)) \times Assimilation\ on\ efficiency)$.

5.2.3.3 AV, PT and PD, [-]

In the first tier of exposure assessment corresponding to the worst case scenario, it is assumed that:

- Avoidance factor (AV): the contaminated diet is not avoided. AV = 1
- Fraction of diet obtained in treated area (PT): animals satisfy their entire food demand in the treated area. PT = 1
- Fraction of food type in diet (PD): animals feed exclusively on contaminated diet. PD = 1

Therefore the factors AV, PT and PD are all set to 1 and can be omitted in the calculation.

5.2.3.4 ETE calculations

For the assessment of secondary poisoning via the consumption of contaminated worms, ETE may be calculated using the following equation C corresponding to $C_{\text{earthworm}}$ as indicated in the TGD part II section 3.8.3.7.

$$\text{ETE} = C \times (\text{FIR}/\text{bw}) \times \text{AV} \times \text{PT} \times \text{PD} \quad (68)$$

In the European TGD (E.C. 2003) $C_{\text{earthworm}}$ is the total concentration of the substance in the worm as a result of bioaccumulation in worm tissues and the burden of the substance in the soil present in the gut.

When using (SANCO/4145 2002) in section 4.3, $C_{\text{earthworm}}$ could be expressed as :

$$C_{\text{worm}} = \text{PEC}_{\text{soil}} \times \text{BCF}_{\text{worm}}$$

with $\text{BCF}_{\text{worm}} = (0.84 + 0.01 K_{\text{ow}}) / f_{\text{oc}} \times K_{\text{oc}}$ and PEC_{soil} (predicted environmental concentration in soil) could corresponds in the first tier exposure assessment to the local concentration of active ingredient in soil adjacent to the house due to wall/foundation and ground application (i.e. $C_{\text{spray, outdoor, foundation}(10\text{cm})}$ see section 4.4.2), and added to local concentration of active ingredient in soil adjacent to the house due to wash-off but only in case of short-term exposure estimate (i.e. $C_{\text{local, spray, outdoor, wall/foundation, wash-off}(10\text{cm})}$).

For the assessment of secondary poisoning via the consumption of contaminated vegetation or insect, ETE should be calculated using the following equation:

$$\text{ETE} = (\text{FIR}/\text{bw}) \times \text{RUD} \times T_{\text{appl}} \times \text{AV} \times \text{PT} \times \text{PD} \times 10^{-4} \quad (69)$$

Table 5.2-6 presents the different variables, parameters and default values of the standard exposure scenarios for secondary poisoning to non-target animals in case of outdoor spray application.

Table 5.2-6: Variables/parameter and default values of the standard emission scenario for the outdoor spray application

Variable/parameter	Symbol	Unit	Default	S/D/O/P
Input:				
Food intake rate of indicator species (fresh weight)	FIR	g.d ⁻¹	Table 5.2-5*	S/P
Body weight of indicator species	bw	g	Table 5.2-7*	S/P
Residue value per unit dose	RUD	mg.kg ⁻¹	Table 5.2-7*	S/P
Quantity of commercial product applied	Q _{prod}	kg.m ⁻²		S
Fraction of active substance in the commercial product	F _{AI}	[-]		S
Application rate of active substance	T _{appl}	kg.m ⁻²	Eq. 43 to 46	S
Avoidance factor of contaminated food (1 = no avoidance, 0 = complete avoidance)	AV	[-]	1	S/D
Proportion of diet obtained in treated area (value between 0 and 1)	PT	[-]	1	S/D
Proportion of food type (vegetation or insects) in the diet of specie of concern (value between 0 and 1; one food type or more types)	PD	[-]	1	S/D
Output:				
Estimated daily uptake of a compound	ETE	mg.kg ⁻¹ .d ⁻¹		O

*) Standard values reported in these tables are only determined for indicator species characteristic of the lawn/garden. It has to report on (SANCO/4145 2002) for other species.

It should be noticed that in this scenario, default value for the proportion of diet obtained in treated area (PT=1) was chosen with reference to guidance document (SANCO/4145 2002) instead of using European TGD (E.C. 2003). In the later, 50% of the diet comes from a local area (represented by the annual average PEC_{local}) and 50% of the diet comes from a regional area (represented by the annual average PEC_{regional}) is the most appropriate for the assessment. As indicated before, the approach retained in this scenario is to estimate the risk of poisoning for birds and mammals eating contaminated insects rather than reflecting the risk of accumulation in the food chain.

The food intake rate per body weight default value and the standard residues are reported in the Table 5.2-7 for standard exposure scenarios to contaminated vegetation and insects.

In the scope of this scenario, residues estimates (normalised to an application rate of 1 kg active ingredient /ha) in vegetation and insects are based on the 90th percentiles of the initial concentration for acute exposure whereas arithmetic means are taken for short-term exposures.

Table 5.2-7: Food intake rates per body weight (FIR/bw) for indicator species and residues values in contaminated vegetation and insects (normalised for an application rate of 1 kg active ingredient/ha)

Indicator species – body weight	Category	FIR/bw	RUD	
			<i>Acute (90%)</i>	<i>Short-term (mean)</i>
Small insectivorous mammal 1 (pipistrelle) – 7.6 g *	Large insects	0.68	14	5.1
Small insectivorous mammal 2 - 10 g	Large insects	0.63	14	5.1
Medium insectivorous mammal – 1100 g – hedgehog *	Large insects	0.18	14	5.1
Large insectivorous mammal – 10100 g (badger) *	Large insects	0.18	14	5.1
Small herbivorous mammal – 25 g	Short grass	1.39	142	76
Medium herbivorous mammal – 1500 g (rabbit) *	Leafy crops	0.32	87	40
Small Insectivorous bird 1 – 10 g	Small insects	1.04	52	29
Small Insectivorous bird 2 (Tree sparrow, robin) – 22 g	Small insects	0.2	52	29
Medium Insectivorous bird – 113 g (blackbird) *	Large insects	0.44	14	5.1
Omnivorous bird – 225 g (magpie) *	Large insects	0.2	14	5.1
Medium herbivorous bird – 300 g	Leafy crops	0.76	87	40
Large herbivorous bird – 3000 g	Short grass	0.44	142	76

*Indicator species considered as relevant for lawn/garden

5.2.3.5 Repeated applications

In case of repeated applications by spraying, insecticide may accumulate on vegetation if residues remain at the end of an interval between two applications. Therefore a multiple application factor (MAF) has to be taken into account. ETE of contaminated food may be expressed as

$$\text{ETE} = (\text{FIR/bw}) \times C \times \text{AV} \times \text{PT} \times \text{PD} \times \text{MAF} \quad (70)$$

MAF is a function of DT_{50} (in the first tier a default value of 10 days for DT_{50} on vegetation is used), the number of applications and the interval between applications (Int).

Default values of MAF have been calculated for residues on short grass and leafy crops for acute and short-term exposures (SANCO/4145 2002) according to (Fletcher *et al.* 1994).

According to (SANCO/4145 2002) it is expected that repeated applications do not cause appreciable accumulation of residues in insects, therefore no MAF will be applied for residues on insects or worms

Table 5.2-8: Multiple Application Factors in acute and short-term exposures for residues on vegetation (SANCO/4145 2002)

Interval (days)	Number of applications											
	2		3		4		5		6		8	
	<i>Acute</i>	<i>Short-term</i>	<i>Acute</i>	<i>Short-term</i>	<i>Acute</i>	<i>Short-term</i>	<i>Acute</i>	<i>Short-term</i>	<i>Acute</i>	<i>Short-term</i>	<i>Acute</i>	<i>Short-term</i>
7	1.4	1.6	1.7	2.0	1.8	2.2	1.9	2.4	1.9	2.5	2.0	2.5
10	1.3	1.5	1.5	1.8	1.6	1.9	1.6	1.9	1.6	2.0	1.6	2.0
14	1.2	1.4	1.3	1.5	1.4	1.6	1.4	1.6	1.4	1.6	1.4	1.6

5.2.3.6 Summary of ETE calculations

To summarise, different ETEs may be calculated according to the time scale of exposure and to the category of diet of the indicator species (see Table 1). In the first tier, the different default equations to calculate ETE for a realistic worst case are expressed as follows:

$$ETE_{acute, flying} = (FIR/bw) \times RUD \times APPL_{ground} \times 0.75 \times 10^{-4} \quad (71)$$

$$ETE_{acute, crawling} = (FIR/bw) \times RUD \times APPL_{ground} \times 1.15 \times 10^{-4} \quad (72)$$

$$ETE_{short-term, insectivorous flying} = (FIR/bw) \times (RUD)_{mean} \times APPL_{ground} \times 2.5 \times 10^{-4} \quad (73)$$

$$ETE_{short-term, insectivorous crawling} = (FIR/bw) \times (RUD)_{mean} \times APPL_{ground} \times 1.5 \times 10^{-4} \quad (74)$$

$$ETE_{short-term, herbivorous, flying} = (FIR/bw) \times (RUD)_{mean} \times APPL_{ground} \times 2.5 \times 10^{-4} \times MAF \quad (75)$$

$$ETE_{short-term, herbivorous crawling} = (FIR/bw) \times (RUD)_{mean} \times APPL_{ground} \times 1.5 \times 10^{-4} \times MAF \quad (76)$$

For the food chain from earthworm to earthworm-eating birds and mammals, it is considered in the first tier that estimated residues in earthworms should be converted to daily dose by multiplying with 1.4 and 1.1 for mammals and birds respectively (SANCO/4145 2002) in section 4.3):

$$ETE_{acute,worm,mammal} = 1.4 \times C_{worm} = 1.4 \times C_{spray, wall/foundation} \times BCF_{worm} \quad (77)$$

$$ETE_{short-term, worm,mammal} = 1.4 \times BCF_{worm} \times (C_{spray, wall/foundation} + C_{spray, wall/foundation,wash-off}) \quad (78)$$

$$ETE_{acute,worm,bird} = 1.1 \times C_{worm} = 1.1 \times C_{spray, wall/foundation} \times BCF_{worm} \quad (79)$$

$$ETE_{short-term, worm,bird} = 1.1 \times BCF_{worm} \times (C_{spray, wall/foundation} + C_{spray, wall/foundation,wash-off}) \quad (80)$$

5.3 Second tier assessment: options for refinement

5.3.1 Daily food intake rate (FIR)

There are limitations in using theoretical models for food daily intake (Crocker *et al.* 2002). The user could use reliable data or information on DEE, energy content, moisture content, assimilation efficiency or dietary composition for the species of concern, which are more relevant to the assessment scenario, instead of the corresponding estimated value in the standard equations.

5.3.2 Concentration of active substance (C)

According to the physico-chemical parameters of the substance, residues are expected to significantly decline in vegetation by different ways such as volatilisation, degradation and metabolisation.

For estimate residues in earthworms (C_{worm}), it will be more realistic to consider that PEC_{soil} corresponds in acute exposure to the local concentration of active ingredient in soil at 1 m from the house due to wall/foundation and ground application (*i.e.* $C_{spray, wall/foundation}$ see section 4.4.2).

5.3.3 Multiple application factor (MAF)

In the first tier MAF is based on a DT_{50} of 10 days. If data show that the disappearance is faster, then the MAF should be recalculated (see (SANCO/4145 2002) for calculation).

5.3.4 Avoidance (AV)

The contaminated diet could be avoided by animals to a certain degree due principally to the probable unattractive smell of insecticide. However, poisoned animals have generally an alteration of their behaviour and predatory birds and mammals may more easily catch poisoned animals. Taking into account these considerations, AV should be greater for insectivorous than for herbivorous species (*i.e.* avoidance of contaminated vegetation > avoidance of contaminated insects). AV factor may be refined if results from an avoidance study are available.

5.3.5 Proportion of diet obtained in treated areas (PT)

The treated area is not expected to be the exclusive area of diet because in line with this exposure scenario for outdoor treatment around the building, a default treated surface of soil of 0.5 m: wide has been proposed. It might be assumed that the proportion of diet obtained in treated area depends on its dimension in relation to the size of the entire garden.

In particular, the proportion of diet of indicator species in the treated area should be proportional to this ratio. Data are available for a typical French (UPJ 2005) and German garden (Vosswinkel *et al.* 2003). Based on this study, it is proposed that the mean size of garden by building is 500 m².

The treated band of soil will then correspond to only 12% of the lawn and indicates a low value of PT even if it is considered that the diet of area is limited to the garden.

However, the contaminated area is expected to be larger from an environmental point of view for three main reasons:

- 1/ Technical data sheets of commercially available formulation indicate that the application of insecticide may be performed on a band of soil and vegetation of 2 – 3 meter wide around the building.
- 2/ Soil adjacent to the treated area should also receive releases due to deposition from spray application and wash-off/run-off from the treated walls.
- 3/ Poisoned animals can migrate outside of the treated area.

In addition, PT is very specific to species and can be estimated from the time spent in the contaminated area. Consequently, PT factors should be greater for species that live in close contact with humans like magpies.

5.3.6 Proportion of different food types in diet (PD)

The fraction of food type in diet depends on the species and may be changed during the year. In addition, the species which are characteristic of the lawn/garden have mixed diet, therefore it will be necessary to calculate partial ETE values for each food type and sum them up to get the overall ETE (see (SANCO/4145 2002) for more details).

5.3.7 Biomagnification in terrestrial food chains

If the active substance is persistent and bioaccumulable, it would be necessary to apply an additional biomagnification model based on TGD (E.C. 2003) and (SANCO/4145 2002).

Chapter 6 References

- Biocides_Steering_Group (1998). Report to DG XI from the Biocides steering Group. Zeist, The Netherlands, TNO: 156.
- Bordereau, C., *et al.* (2002). Termites, biologie lutte réglementaire, CTBA, CNRS, Université de Bourgogne.
- Bremmer, H. J., *et al.* (2006). Pest Control Products fact Sheet to assess the risks for the consumer (update version for ConsExpo 4). Bilthoven, RIVM: 80.
- Cattani, M., *et al.* (2001). "Potential Dermal and Inhalation Exposure to Chlorpyrifos in Australian Pesticide Workers." The Annals of occupational hygiene 45(4): 299-308.
- Chang, J.-Y., *et al.* (1998). "Aliphatic aldehydes and allethrin in mosquito-coil smoke." Chemosphere 36(3): 617-624.
- Coosemans, M., *et al.* (1999). "La protection du voyageur contre les piqûres de moustiques." Medecine et Maladies Infectieuses 29(Supplement 3): S390-S396.
- Copping, L. G. (2004). The manual of Bicontrol Agents, BCPC.
- Crocker, D., *et al.* (2002). Project PN0908: methods for estimating daily food intake of wild birds and mammals. York, Central Science Laboratory: 22.
- E.C. (2002). Technical Notes For Guidance, Human Exposure To biocidal Products, Guidance on Exposure, European Commission, DG Environment: 400.
- E.C. (2003). Technical Guidance Document on Risk Assessment in support of Commission Directive 93/67/EEC on Risk Assessment for new notified substances, Commission Regulation (EC) N° 1488/94 on Risk Assessment for existing substances, Directive 98/8/EC of the European Parliament and of the Council concerning the placing of biocidal products on the market. Luxembourg, Office for Official Publications of the European Communities.
- FAO/WHO (2002). Manual on Development and Use of FAO and WHO Specifications for Pesticides. Rome, FAO
WHO: 264.
- Fischer, D., *et al.* (1997). "Summary of field measurement of pesticide concentrations in invertebrate prey of birds." Unpubl. Ms.
- Fletcher, J. S., *et al.* (1994). "Literature review and evaluation of the EPA food-chain (Kenaga) nomogram, in instruments for estimating pesticide residues on plants." Environmental Toxicology and Chemistry 9: 1383-1391.
- Frankin, C. A., *et al.* (2004). Occupational and Residential Exposure Assessment for Pesticides, John Wiley & Sons, Ltd.
- Ganzelmeier, H., *et al.* (1995). "Studies on the spray drift of plant protection products." Blackwell Wissenschafts-Verlag GmbH berlin/Wien. Mitteilungen aus der Biologischen Bundesanstalt für Land- und Forstwirtschaft 305: pp. 111.
- Garrod, A. N. I., *et al.* (1998). "Occupational Exposure through Spraying Remedial Pesticides." The Annals of Occupational Hygiene 42(3): 159-165.
- Gerry, A. C., *et al.* (2004). Pest Notes: Flies, IPM Education and Publications, University of California Statewide IPM Program: 5.
- Gosselin, *et al.* (1984). Clinical Toxicology of Commercial Products, 5th ed. Baltimore: Williams and Wilkins.
- Hollis, J., *et al.* (2004). HardsPEC: A first-tier model for estimating surface- and ground-water exposure resulting from herbicides applied to hard surfaces., Final Report for the Pesticide Safety Directorate (DEFRA project PL0531): 124 pp.
- HSE (1987). Amendment to the control of Abestos at work regulation 1987 and acop Regulatory impact assessment, HSE: 97.
- Kenaga, E. E. (1973). Factors to be considered in the evaluation of toxicity of pesticides to birds in their environment. Environmental Quality and safety. New York, Academic Press. II: 166-181.

- Klotz, J. (2005). Pest Notes: Ants. T. E. M. L. Flint, IPM Education and Publications, University of California Statewide IPM Program.
- Krierger, R. I., *et al.* (2003). "Octachlorodipropyl Ether (S-2) Mosquito Coils Are Inadequately Studied for Residential Use in Asia and Illegal in the United States." Environmental Health Perspectives 111(12): 1439-1442.
- Landers, A. (*in press*). Spray drift management - An international problem., Cornell University, Department of Agricultural and biological engineering, Riley Robb Hall, Ithaca, NY 14853-5701.
- Larsen, P. (2003). Supplement to the methodology for risk evaluation of biocides: Emission scenario document for biocides used as rodenticides, Danish EPA. CA-Jun03-Doc.8.2-PT14: pp. 74.
- Liu, W., *et al.* (2003). "Mosquito Coil Emissions and Health Implications." Environ Health Perspect 111(12): 1454-1460.
- Mallis, A. (2004). Handbook Of Pest Control.
- Matoba, Y., *et al.* (1994). "An indoor simulation of the behavior of insecticides supplied by an electric vaporizer." Chemosphere 28(3): 435-451.
- Metzger, M. E. (2004). Managing Mosquitoes in Stormwater Treatment Devices., T. E. M. L. Flint, IPM Education and Publications, University of California Statewide IPM Program.
- Migne, V. (2002). Supplement to the methodology for risk evaluation of biocides: Emission scenario document for biocides used as masonry preservatives (product type 10). Verneuil en Halatte, INERIS: 62.
- Miller, D. M., *et al.* (2003). "Least Toxic Methods of Cockroach Control." Entomology and Nematology Department, Florida Cooperative Extension Service, Institute of Food and Agricultural Sciences, University of Florida. First published: April 1993. Revised: March 2003.(ENY-258).
- NIOSH (1997). NIOSH Pocket guide to Chemical Hazards, DHHS (NIOSH) Publication.
- OECD (1992). Screening Assessment Model System (SAMS). A Program of Simple Models for Exposure Assessment to Chemicals., OECD environment Directorate.
- OECD (2003). Emission scenario document for wood preservatives, Organisation for Economic Co-operation and Development: 215.
- OECD (2005). Emission Scenario Document for Insecticides for Stables and Manure Storage Systems, Organisation for Economic Co-operation and Development: 96.
- OECD (2005). Emission Scenario Document for Insecticides for Stables and Manure Storage Systems, Organisation for Economic Co-operation and Development: 96.
- Ogg, B., *et al.* Cockroach control Manual, University of Nebraska Institute of agriculture and Natural Resources.
- Ogg, C., *et al.* (2006). "Subterranean Termites: A Handbook for Homeowners." 54.
- Prisse, G. (2002). Dératisation - Désinsectisation - Désinfection. Le Guide de l'applicateur. Deuil la Barre, France, PC MEDIA.
- PSD (1992). UK POEM Model.
- Ramwell, C. T. (2002). Herbicide partitioning to concrete, asphalt and railway ballast., Cranfield Centre for Ecochemistry report for the Department of Environmental Food and Rural Affairs: 30 pp.
- Rozendaal, J. A. (1997). Vector control: Methods for use by individuals and communities. Geneve, OMS: 412.
- Samuel, O., *et al.* (2005). "Profil Toxicologique des insecticides retenus pour le contrôle des insectes adultes impliqués dans la transmission du virus du Nil Occidental au Quebec." Institut National de Santé Publique du Quebec.
- SANCO/4145 (2002). Guidance Document on Risk Assessment for Birds and Mammals Under Council Directive 91/414/EEC, European Commission.
- Teske, M. E., *et al.* (2002). "AgDRIFT: A Model for Estimating Near-Field Spray Drift from Aerial Applications." Environmental Toxicology and Chemistry 21: 659-671.

- Thomas, C. H. (1994). MAGPIES. Prevention and Control of Wildlife Damage. G. E. Larson. Washington.
- Tomlin (2005). "The Pesticide Manual, a World Compendium, 14e Edition." 1344.
- UPJ (2005). Evaluation du risque opérateur en jardins amateurs: Modèle d'exposition jardin, Union des entreprises pour la Protection des Jardins et Espaces verts: 34.
- Van der Poel, P. (2000). Supplement to the methodology for release evaluation: Proposal for the formats of names, parameters, variables, units and symbols to be used in emission scenario documents, National Institute of Public Health and the Environment (RIVM), Bilthoven, The Netherlands,.
- van der Poel, P., *et al.* (2002). Emission Scenario Document for Biocides
Emission scenarios for all 23 product types of the Biocidal Products Directive (EU Directive 98/8/EC). Bilthoven, RIVM: 349.
- Verschueren, K. (1996). Handbook of Environmental Data on Organic Chemicals. New York, NY: Van Nostrand Reinhold Co.
- Vosswinkel, *et al.* (2003). Model Garden Plan. Basis for Risk Assessments. B. E. Science.
- WHOPES (2006). Pesticides and their application for the control of vectors and pests of public health importance, World Health Organization.

Chapter 7 Appendices

7.1 Appendix 1: Some active substance in insecticide formulations

This section describes the most important substances known to be used as insecticides at the time when this report was written but does not reflect any representativeness of the market.

Insecticides fall into two types: inorganic and organic compounds. Among the first ones, silica, methyl bromide and boric acid are mainly used whereas the organic insecticides are split up into several groups. The most representative biocide insecticides on the market, when this report was written, are pyrethroids, organophosphorus, organochlorine compounds, carbamates and halogenated hydrocarbons. From one compound, chemists may derive many molecules to increase their characteristics or change their properties.

- Pyrethrum is a natural insecticide obtained from the flower heads of tropical chrysanthemum and has excellent knockdown properties at low concentrations. Pyrethrum is extracted from chrysanthemum flowers (*Chrysanthemum cineraraefolium*). The pyrethrum extract is a mixture of three natural esters of chrysanthemic acid named pyrethrin I (Pyrethrin I/Jasmolin I/Cinerin I) and of three natural esters of pyrethrum acid named pyrethrum II (pyrethrum II/Jasmoline II/Cinerine II). The Pyrethrin;Jasmolin:Cinerin ratio would be 71:21:7 and the Pyrethrin I:Pyrethrin II ratio would be variable. These products are usually combined with butoxide piperonyl or N-octyl bicycloheptene dicarboximide. These compounds increase the pyrethrum stability and prevent from detoxification. Pyrethrum inhibits the closure of sodium canals. The insects become paralyzed and die (Samuel *et al.* 2005). The downside to using natural pyrethrum is that it is very expensive. Synthetic pyrethroids represent a less expensive and highly effective alternative.

Pyrethrins have a molecular weight range 316-374 and are not soluble in water. The pyrethrum concentration in powder products is about 1-3% and the concentration in insecticide sprays is usually 1-2% (NIOSH 1997) although more pyrethrum-based household insecticide spray products can rely on levels of pyrethrins as low as 0.3-0.5%. The common solvents in pyrethrum sprays are generally kerosene and naphta (Gosselin *et al.* 1984) although more recently it has become commonplace to produce oil-in-water emulsion formulations. It is common for pyrethrum-based formulations to contain synergist which inhibits an insect enzyme, that would under normal circumstances, detoxify pyrethrins, the most well known being piperonyl butoxide (PBO). The addition of PBO provides the pyrethrum formulation with increased efficacy

- Pyrethroïds are synthetic compounds that have similar chemistry to natural pyrethrum. They act as contact poisons affecting the insect nervous system creating multiple potentials across the membranes by delaying the closing of the sodium ion channel. Pyrethroids can be co-formulated with a synergist which allows the primary insecticide to be more effective by inhibiting an enzyme the insect uses to detoxify the pyrethrins, one of the most well known is piperonyl butoxide. However, the presence of the synergist is not essential. Permethrin is an example of a pyrethroïd (Figure 7.1-1): this synthetic insecticide is similar to dichlorochrysanthemic acid. Permethrin is effective against a large variety of insects in agricultural, sanitary and residential domains. Permethrin is toxic by ingestion and contact with a light repellent effect (Tomlin 2005).

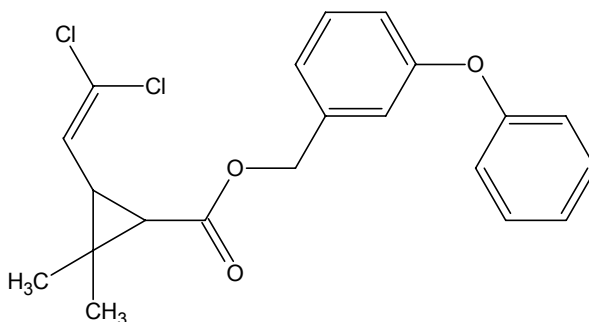

Figure 7.1-2: Permethrin

- Organophosphorous compounds (Figure 7.1-3:) possess anticholinesterase activity and are very toxic. Acetylcholine is a neurotransmitter essential to the nerve impulse. In the normal situation, the enzyme acetylcholinesterase (AChE) hydrolyzes acetylcholine. The synapse is then ready for the transmission of a new nervous impulse. In the presence of organophosphorous compounds the AChE activity is inhibited. The synapse cannot transmit a new nervous impulse. Organophosphorous are usually prepared in organic solvents or in mineral oil emulsions. Chlorpyrifos, chlorpyrifos-methyl, diazinon, pirimphos-methyl, fenitrothion and malathion and dichlorvos are some example of organophosphorous compounds.

Example Dichlorvos (Figure 7.1-4):

Dichlorvos is an organophosphate compound used to control household insects and to protect public health and stored product. It is effective against mushroom flies, aphids, spider mites, caterpillars, thrips, and white flies in greenhouse. It acts against insects as both a contact and a stomach poison. It is available as an aerosol and soluble concentrate.

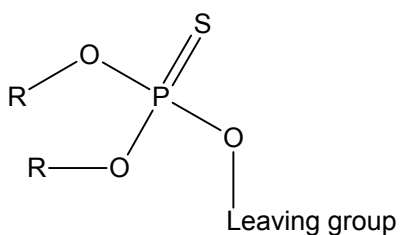

Figure 7.1-3: General chemical structure of organophosphorous compounds

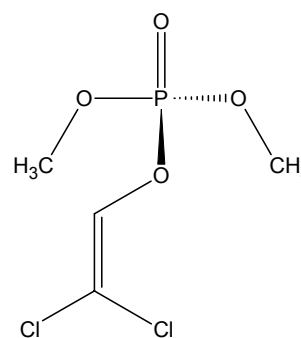

Figure 7.1-4: Dichlorvos

- Organochlorine compounds:

As these compounds are very persistent they have been largely prohibited in most industrial countries.

For example, lindanes' disappearance from soil is around 3-10 years (Verschueren 1996). In 2000, the EU Standing Committee on Plant Health in Brussels voted to ban lindane for pesticides applications. The ban covers all agricultural and gardening applications, but doesn't prevent its continued use in domestic products such as an ant killer. Then, the regulation (EC) No 850/2004 of the European Parliament and of the Council of 29 April 2004 on persistent organic pollutants and amending Directive 79/117/EEC prohibited the production, placing on the market and use of substances listed in Annex I, whether on their own, in preparations or as constituents of articles. Lindane is part of this Annex I as well as other organochlorine compounds like chlordane and DDT. However, lindane could still be authorised for specific applications.

- Carbamates :

Carbamates are derived from the molecule of propoxur. They are unstable in soil (for example in aerobic, half-life of methomyl is 1 day). They are often used to replace the organochloride compounds that are too persistent. They inhibit the cholinesterase and other esterase activities in the same way as for the organophosphorous compounds. But this inhibition is less strong.

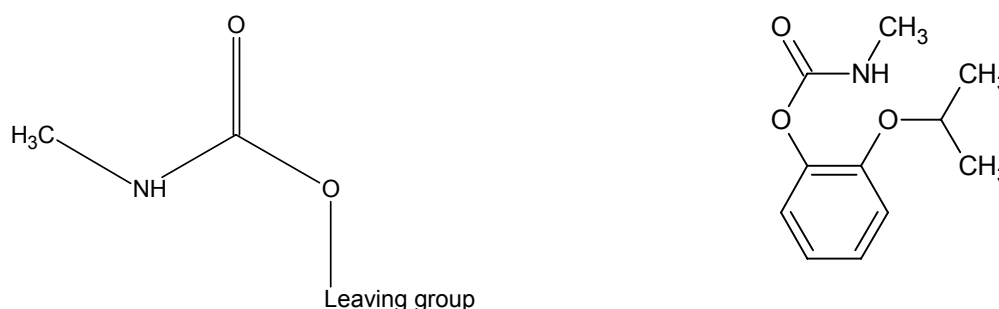

Figure 7.1-5: General chemical structure of carbamates **Figure 7.1-6: Propoxur**

- The halogenated hydrocarbons:

Paradichlorobenzene is an example of a halogenated hydrocarbon widely used against mites. The substance has been evaluated in the scope of the Commission Regulation (EC) No. 1488/94 on risk assessment for existing substances. The conclusion of the risk assessment states that for consumers there is a need for specific measures to limit the risks (Risk-Assessment Report Vol.48, 2004 on: 1,4-dichlorobenzene, CAS#: 106-46-7, EINECS#: 203-400-5. Publication: EUR 21313 EN, available at <http://ecb.jrc.it/biocides/>).

This conclusion was reached because of concerns for carcinogenicity as a consequence of inhalation exposure arising from use (among others) of moth repellents.

With regards to the strategy for limiting this risk presented at the 10th risk limiting strategy meeting of 10-11st November 2005 (Council regulation (EEC) 793/93), the strategy for paradichlorobenzene uses as insecticides and as repellent is still under discussion at the Commission: an immediate ban of paradichlorobenzene for all uses as repellent and insecticides or a ban in abeyance to the assessment of substitutes within the framework of Directive 98/8/EC.

- Hormonal compounds are sometimes used as insecticides but too few information about their physical-chemical characteristics and their modes of action is known. Most of these compounds are known as insect growth regulators which interfere with insect growth cycle inhibiting full development. Methoprene, pyriproxyfen are a few examples of these substances.

Insecticides may be responsible for four types of effects

- A shock effect (or knockdown effect): the target insects are struck by insecticides
- A skidded effect: the target insects are flushed out.
- A persistent effect: the insecticide activity in time depends on the use. Usually, formulators mix two or three active substances to combine their effects. The nervous system is mostly targeted. Insecticides break the transmission of the nervous impulse through the cholinesterase activity inhibition. However, other mode of action might be involved (see carbamates, hormonal compounds...)
- A dehydration effect (*e.g.* for silica compounds): most probably through absorption of the lipid layer covering insects chitin protection, which then leads to desiccation and death of the target organism (see Manual of Decision available at <http://europa.eu.int/comm/environment/biocides/manual.htm>).
- The bacterial insecticide (bacterium):

Some bacteria have an insecticidal activity. They are most of the time naturally occurring soil bacteria with specific activity against a narrow range of fly pests. They all display different spectra and levels of activity correlated with the nature of the toxins produced during sporulation process. *Bacillus thuringiensis* strains produce a large diversity of toxins. However, among the most frequently used bacteria *Bacillus thuringiensis israelensis* (*Bti*) and *Bacillus sphaericus* allow for the effective control of many of the world's vector and nuisance pests through the production of crystal inclusion bodies with insecticide properties.

Little is known about the mode of action of these toxins. Nevertheless, for *Bti*, it has been demonstrated that the activity is due to the binding of the toxins on the midgut brush border membrane after ingestion and protoxin activation within the mosquito larval midgut. Once in the insect gut, the crystal proteins are solubilised and converted into a combination of smaller toxins. These toxins modify the permeability of the cells and cause the disruption as final effect. (Copping 2004). They may for example be insecticide to larvae of the orders of Lepidoptera, Diptera and to both larvae and adults of a few Coleoptera.

The bacteria could also be produced by controlled fermentation in deep tanks of sterilised nutrient liquid medium.

7.2 Appendix 2: Emission factors to the applicator during the application step by spraying

- Airs space treatment with a self-pressurised aerosol dispenser:

it is considered that the applicator remains in the room for 30 seconds after application before exiting. The duration of release is 6 seconds with a continuous discharge rate of 2.3 g.s⁻¹

Table 7.2-1: Calculation of the contamination during an air space treatment with an aerosol dispenser (ACP - SC 11000 – consumer exposure to non agricultural pesticide products)

	Hands and forearm	Legs, Feet and face	Inhaled
Exposure 75 th	156 mg.min ⁻¹	113 mg.min ⁻¹	234mg.m ⁻³
Duration of the exposure	36 s # 0.6 min	36 s # 0.6 min	The inhalation rate is set to 14m ³ .d ⁻¹ 36s # 5,8x10 ⁻³ m ³
Calculation	156 * 0.6 = 93.6 mg	113 * 0.6 = 67.8 mg	234*5.8x10 ⁻³ = 1.36 mg
Total	162.8 mg		

Then the emission factor $F_{application, applicator}$ could be calculated:

$$F_{application, applicator} = \frac{162.8 \cdot 10^{-3}}{2.3 \times 6} = 0.012$$

- Air space treatment with a trigger spray:

With the same reasoning the emission to the applicator could be calculated for a treatment of volume with a hand-held trigger spray. The subjects remained in the room for 30 seconds after the application before exiting. The duration of release is 6 seconds with an amount of product applied of 4.4g.

Table 7.2-2: Calculation of the contamination during an air space treatment with a trigger spray (ACP - SC 11000 – consumer exposure to non agricultural pesticide products)

	Hands and forearm	Legs, Feet and face	Inhaled
Exposure 75 th	136 mg.min ⁻¹	42.4 mg.min ⁻¹	90.2 mg.m ⁻³
Duration of the exposure	36 s # 0.6 min	36 s # 0.6 min	The inhalation rate is set to 14m ³ .d ⁻¹ 36s # 5.8x10 ⁻³ m ³
Calculation	136 * 0.6 = 81.6 mg	42.4 * 0.6 = 25.4 mg	90.2 * 1,62.10 ⁻⁴ = 0.52 mg
Total	107.6 mg		

$$\rightarrow F_{application, applicator} = \frac{107.6 \cdot 10^7}{4.4} = 0.024$$

- Treatment of surface with an aerosol dispenser:

Extracted from the questionnaires, the event duration of the treatment of surface is around 6 seconds with a continuous discharge rate of 2.3 g.s⁻¹. Then the applicator remains in the room for 30 seconds after the application.

Table 7.2-3: Calculation of the contamination during a surface treatment with an aerosol dispenser (ACP - SC 11000 – consumer exposure to non agricultural pesticide products)

	Hands and forearm	Legs, Feet and face	Inhaled
Exposure 75 th	64.7 mg.min ⁻¹	35.7 mg.min ⁻¹	35.9 mg.m ⁻³
Duration of the exposure	36 s # 0.6 min	36 s # 0.6 min	The inhalation rate is set to 14m ³ .d ⁻¹ 36s # 5.8x10 ⁻³ m ³
Calculation	64.7 * 0.6 = 38.8 mg	35.7 * 0.6 = 21.4 mg	35.9 * 5.8x10 ⁻³ = 0.2 mg # 0
Total	60.4 mg		

$$\rightarrow F_{application, applicator} = \frac{60.4 \cdot 10^{-3}}{2.3 \times 6} = 0.004$$

- Treatment of surface with a trigger spray

Table 7.2-4: Calculation of the contamination during a surface treatment with a trigger spray (ACP - SC 11000 – consumer exposure to non agricultural pesticide products)

The duration of release is 6 seconds with an amount of product applied of 4.4g

	Hands and forearm	Legs, Feet and face	Inhaled
Exposure 75 th	36.1 mg.min ⁻¹	9.7 mg.min ⁻¹	10.5 mg.m ⁻³
Duration of the exposure	36 s # 0.6 min	36 s # 0.6 min	The inhalation rate is set to 14m ³ .d ⁻¹ 36s # 1.62.10 ⁻⁴ m ³
Calculation	36.1 * 0.6 = 21.7 mg	9.7 * 0.6 = 5.8 mg	10.5*1.62.10 ⁻⁴ = 0.001 mg # 0
Total	27.5 mg		

$$\rightarrow F_{\text{application, applicator}} = \frac{27.5 \cdot 10^{-3}}{4.4} = 0.006$$

The emission factors below concern only the emissions to the professional applicator that uses compressed sprayer:

The values of exposure have been extracted from the TNGh “spraying model 1”: spraying at a pressure of 1 to 3 bars and “spraying model 2”: Spraying at a pressure of 4 to 7 bars. This exposure model is principally dedicated to the professionals.

- Treatment with a low pressure sprayer (1 to 3 bars):

The application duration mentioned in the TNGh is 40 minutes. Moreover the quantity of in-use product is 5 litres (density = 1) (spraying model 1). Then it is possible to calculate the emission to the applicator during the application step with this kind of sprayer.

Table 7.2-5: Calculation of the contamination during the use of compressed sprayer (1 to 3 bars): (HSE surveys 1992-3, IOM study on PPE, 1996)

	Dermal 95 th	Into gloves 95 th	By inhalation 75 th
Exposure	251 mg.min ⁻¹	39.4 mg.min ⁻¹	130 mg.m ³
Duration of the exposure	40 minutes	40 minutes	The inhalation rate is set to 14m ³ .d ⁻¹ . 40 min # 0.389m ³
Calculation	40*0.251 = 10.04g	40 * 0.0394 = 1.58g	0.13 * 0.39 = 0.05g
Total	11.67g		

$$\rightarrow F_{application, applicator} = \frac{11.67}{5000} = 0.0023$$

- Treatment with a low pressure sprayer (4 to 7 bars)

The application duration mentioned in the TNGh (page 113) is 40 minutes. Moreover the quantity of in-use product is 5 litres (density = 1) (E.C. 2002). Then it is possible to calculate the emission to the applicator during the application step with this kind of sprayer.

Table 7.2-6: Calculation of the contamination during the use of compressed sprayer (4 to 7 bars): (Garrod et al. 1998)

	Dermal 95 th	Into gloves 95 th	Into shoes 75 th	By inhalation 95 th
Exposure	2100 mg.min ⁻¹	191 mg.min ⁻¹	5.4 mg.min ⁻¹	198 mg.m ³
Duration of the exposure	40 minutes	40 minutes	40 minutes	The inhalation rate is set to 14m ³ .d ⁻¹ . 40 min # 0.389m ³
calculation	40*2,1 = 84g	40 * 0.191 = 7.64g	40 * 0.005 = 0.2 g	0.389 * 0.198 = 0.08 g
Total	92 g			

$$\rightarrow F_{application, applicator} = \frac{92}{5000} = 0.018$$

7.3 Appendix 3: Estimates of fall – time for various droplet sizes

The following table is extracted from the (Biocides_Steering_Group 1998) report.

Table 7.3-1: Fall-time extracted from (Biocides_Steering_Group 1998) report

Droplet diameter (µm)	Fall time from 3 meters	Fall from 2.5 meters (extrapolation)
1	28 hours	23 hours 20
10	17 minutes	14 minutes 12 seconds
20	4 minutes	3 minutes 20 seconds
50	41 seconds	34 seconds
100	11 seconds	9 seconds
200	4 seconds	3 seconds
500	2 seconds	2 seconds

7.4 Appendix 4: Details emission factors to the applicator during the application step by spraying

- Broadcast powder treatment:

According to the technical note for guidance on human exposure (E.C. 2002), exposure values for broadcast powder treatment are mentioned. (Bremmer *et al.* 2006) mentioned the values presented in the TNGh and provide a description of the treatment. Default value for the quantity of product applied and also the application rate. In this report, the application rate is 60g per square meter. And the application duration is 5 minutes per square meter. Then the application rate is $60/5 = 12\text{g}\cdot\text{min}^{-1}$.

Based on this information, the emission to the applicator is proposed in the Table 7.4-17.4-1.

Table 7.4-1: Calculation of the emission to the application during a broadcast powder treatment: ACP - SC 11000 – consumer exposure to non agricultural pesticide products & (Bremmer *et al.* 2006)

	Dermal 75 th Hand and Forearl	Dermal 75 th Legs, feet and face	By inhalation 75 th
Exposure	$2.5\text{ mg}\cdot\text{min}^{-1}$	$3.2\text{ mg}\cdot\text{min}^{-1}$	$1.9\text{ mg}\cdot\text{m}^3$
Duration of the exposure	1 minutes	1 minutes	The inhalation rate is set to $14\text{m}^3\cdot\text{d}^{-1}$ 1 min # 0.009 m^3
calculation	2.5 mg	3.2 mg	$0.009 * 1.9=0.018.\text{mg}$
Total	$5.72\text{ mg} = 5.72 * 10^{-3}\text{g}$		

$$\rightarrow F_{\text{application, applicator}} = \frac{5.72 \cdot 10^{-3}}{12} = 4.76 \cdot 10^{-4}$$

In regard with this value, the emission to the applicator during the application step is considered in this document as negligible for the environment.

7.5 Appendix 5: Summary of variables in text and equations**Summary of variables used in texts and equations in chapter 3 “scenarios for indoor application”**

Symbol	Parameter	Unit	S/D/O/P
$AREA_{treated,1}$	Area treated with the insecticide product by spraying	m ²	P
$AREA_{treated,2}$	Area treated with the insecticide product by application of gel	m ²	P
$AREA_{treated,3}$	Area treated with the insecticide product by dusting	m ²	P
E_{air}	Emission to air	kg.d ⁻¹	O
E_w	Emission to wastes	kg.d ⁻¹	O
E_{ww}	Emission to waste waters	kg.d ⁻¹	O
$E_{application,air,1}$	Emission to air during the application by spraying	kg.d ⁻¹	O
$E_{application,applicator,1}$	Emission to the applicator during the application by spraying	kg.d ⁻¹	O
$E_{application,floor,1}$	Emission to the floor during the application by spraying	kg.d ⁻¹	O
$E_{application,treated,1}$	Emission to the applicator during the application by spraying	kg.d ⁻¹	O
$E_{prep,air,1}$	Emission to air during the preparation step for spraying applications	kg.d ⁻¹	O
$E_{prep,applicator,1}$	Emission to the applicator during the preparation step for spraying applications	kg.d ⁻¹	O
$E_{prep,floor,1}$	Emission to the floor during the preparation step for spraying application	kg.d ⁻¹	O
$E_{application,air,2}$	Emission to air during the application of gel insecticide	kg.d ⁻¹	O
$E_{application,applicator,2}$	Emission to the applicator during the application of gel insecticide	kg.d ⁻¹	O

$E_{application, treated, 2}$	Emission to the treated surface during the application of gel insecticide	kg.d ⁻¹	O
$E_{application, air, 3}$	Emission to air during the dusting of powders	kg.d ⁻¹	O
$E_{application, applicator, 3}$	Emission to the applicator during the dusting of powders	kg.d ⁻¹	O
$E_{application, floor, 3}$	Emission to the floor during the dusting of powders	kg.d ⁻¹	O
$E_{application, treated, 3}$	Emission to the treated surface during the dusting of powders	kg.d ⁻¹	O
$E_{prep, air, 3}$	Emission to air during the preparation step for dusting application	kg.d ⁻¹	O
$E_{prep, applicator, 3}$	Emission to the applicator during the preparation step for dusting application	kg.d ⁻¹	O
$E_{prep, floor, 3}$	Emission to the floor during the preparation step for dusting application	kg.d ⁻¹	O
$E_{application, air, 4}$	Emission to air during the injection of insecticide	kg.d ⁻¹	O
$E_{application, applicator, 4}$	Emission to the applicator during the injection of insecticide	kg.d ⁻¹	O
$E_{application, floor, 4}$	Emission to the floor during injection of insecticides	kg.d ⁻¹	O
$E_{application, treated, 4}$	Emission to the treated surface during the injection of insecticide	kg.d ⁻¹	O
$E_{prep, air, 4}$	Emission to air during the preparation step for application by injection	kg.d ⁻¹	O
$E_{prep, applicator, 4}$	Emission to the applicator during the preparation step for application by injection	kg.d ⁻¹	O
$E_{prep, floor, 4}$	Emission to the floor during the preparation step for application by injection	kg.d ⁻¹	O
$E_{local, air, 5}$	Local emission to air during a treatment with fumigant or gas	kg.d ⁻¹	O
$E_{application, air, 6}$	Emission to air during the use of the device/diffuser	kg.d ⁻¹	O

$E_{application, floor,6}$	Emission to the floor during the use of the device/diffuser	kg.d ⁻¹	O
$E_{cleaning, air}$	Emission to air during cleaning events	kg.d ⁻¹	O
$E_{applicator,w}$	Emission from applicator to wastes during the cleaning step	kg.d ⁻¹	O
$E_{applicator,ww}$	Emission from applicator to waste water during cleaning step	kg.d ⁻¹	O
$E_{treated,w}$	Emission from floor/treated to wastes during the cleaning step	kg.d ⁻¹	O
$E_{treated,ww}$	Emission from floor/treated to waste waters during the cleaning step	kg.d ⁻¹	O
F_{AI}	Fraction of active substance in the product applied.	[-]	S
F_{CE}	Cleaning efficiency	-	P
F_{disin}	Fraction of disintegration product during the application	[-]	D: 0.001
$F_{application, air,1}$	Fraction emitted to air during the application by spraying	[-]	D: 0.02
$F_{application, applicator,1}$	Fraction emitted to the applicator during the application by spraying	[-]	D: 0.02
$F_{application, floor,1}$	Fraction emitted to the floor during the application by spraying	[-]	P
$F_{application, treated,1}$	Fraction emitted to treated surface during the application by spraying	[-]	P
$F_{prep, air,1}$	Fraction emitted to air during the preparation step for spraying applications	[-]	D: 0
$F_{prep, applicator,1}$	Fraction emitted to the applicator during the preparation step for spraying applications	[-]	P
$F_{prep, floor,1}$	Fraction emitted to the floor during the preparation step for spraying applications	[-]	P
$F_{application, air,2}$	Fraction emitted to air during the application of gel insecticide	[-]	D: 0

$F_{application, applicator, 2}$	Fraction emitted to the applicator during the application of gel insecticide	[-]	D: 0
$F_{application, treated, 2}$	Fraction emitted to treated surface during the application of gel insecticide	[-]	D: 1
$F_{application, air, 3}$	Fraction emitted to air during the dusting of powders	[-]	D: 0.02
$F_{application, applicator, 3}$	Fraction emitted to the applicator during the dusting of powders	[-]	D: 0
$F_{application, floor, 3}$	Fraction emitted to the floor during the dusting of powders	[-]	D: 0.18
$F_{application, treated, 3}$	Fraction emitted to treated surface during the dusting of powders	[-]	D: 0.8
$F_{prep, air, 3}$	Fraction emitted to air during the preparation step for dusting applications	[-]	D: 0
$F_{prep, applicator, 3}$	Fraction emitted to the applicator during the preparation step for dusting applications	[-]	D: 0
$F_{prep, floor, 3}$	Fraction emitted to the floor during the preparation step for dusting applications	[-]	D: 0
$F_{application, air, 4}$	Fraction emitted to air during the injection of insecticide	[-]	D: 0
$F_{application, applicator, 4}$	Fraction emitted to the applicator during the injection of insecticide	[-]	D: 0.001
$F_{application, floor, 4}$	Fraction emitted to the floor during the injection of insecticide	[-]	D: 0.05
$F_{application, treated, 4}$	Fraction emitted to treated surface during the injection of insecticide	[-]	D: 0.949
$F_{prep, air, 4}$	Fraction emitted to air during the preparation step for application by injection	[-]	D: 0
$F_{prep, applicator, 4}$	Fraction emitted to the applicator during the preparation step for application by injection	[-]	P
$F_{prep, floor, 4}$	Fraction emitted to the floor during the preparation step for application by injection	[-]	P
$F_{application, air, 5}$	Fraction emitted to air during fumigation	[-]	D: 0.98

$F_{application, applicator,5}$	Fraction emitted to the applicator during fumigation	[-]	D: 0
$F_{application, air,6}$	Fraction emitted to air during the use of the device/diffuser	[-]	D: 0.9
$F_{application, floor,6}$	Fraction emitted to floor during the use of the device/diffuser	[-]	D: 0.1
$F_{applicator,w}$	Fraction emitted to solid wastes by the applicator during the cleaning step	[-]	P
$F_{applicator,ww}$	Fraction emitted to waste water by the applicator during the cleaning step	[-]	P
F_w	Fraction emitted to solid wastes during the cleaning step	[-]	P
F_{ww}	Fraction emitted to waste water during the cleaning step	[-]	P
F_{ret}	Fraction of retention product in goods during the application	[-]	D: 0.02
N_{appl}	Number of applications		
$N_{appl, building,1}$	Number of spray applications per day per building	[d ⁻¹]	P
$N_{appl, building,2}$	Number of gel application per day per building	[d ⁻¹]	P
$N_{appl, building,3}$	Number of applications per day	d ⁻¹	D
$N_{appl, building,4}$	Number of application per building	d ⁻¹	1
$N_{drilling}$	Number of drilling per linear meter	drilling.m ⁻¹	S
N_{point}	Number of gel points per area	point.m ⁻²	P
$N_{prep, building,1}$	Number of preparations per day for spraying applications	[d ⁻¹]	P
$N_{prep, building,3}$	Number of preparations per day per building for dusting application	[d ⁻¹]	P
$N_{prep, building,4}$	Number of preparations per day per building for application by injection	[d ⁻¹]	D: 1

$Q_{prod,3}$	quantity of commercial product applied per area	kg.m ⁻²	S
$Q_{prod,5}$	Amount of product used for fumigant/gas	kg	S
$Q_{prod,6}$	Quantity of commercial product contained in the device	g	S
$Q_{prod, injected\ drilling}$	quantity of in use product injected per drilling	l.drilling ⁻¹	S
$Q_{prod, point}$	Quantity of commercial product contained in a gel point of insecticide	g.point ⁻¹	S
$Q_{prod, prep,1}$	Quantity of commercial product used for the preparation step for the spraying treatment of one building	g	S
$Q_{prod, prep,3}$	Quantity of commercial product used for the preparation step for the dusting treatment of one building	g	S
$Q_{prod, prep,4}$	Quantity of commercial product used for the preparation step for the treatment of one building	g	S
T_{DAY}	Duration of use per day	h.d ⁻¹	S
$T_{emission}$	Number of emission days for the treatment	d	D: 1
T_{MAX}	Maximum duration of use of the device/diffuser	h	S
$VOLUME_{treated,1}$	Mean volume of a room to be treated by spraying	m ³	D:58
$Wall_{length}$	Length of the perimeter wall building	m	P

Summary of variables used in texts and equations in chapter 4 “scenarios for outdoor application”

Symbol	Parameter	Unit	S/D/O/P
$AREA_{crawling}$	Area of walls and ceiling (crawling space) treated per day - private house - public/industrial building	$m^2.d^{-1}$	D/S 156 -
$AREA_{crawling(h)}$	Area of upper part of the crawling space treated per day (private house)	$m^2.d^{-1}$	D: 156
$AREA_{exposed}$	Area directly exposed to insecticide	$m^2.d^{-1}$	
$AREA_{exposed_ind}$	Area indirectly exposed to insecticide (terrace of garden area)	$m^2.d^{-1}$	
$AREA_{foundation}$	Area of foundation treated per day - private house - public, commercial, or industrial building	$m^2.d^{-1}$	D 25 125
$AREA_{house}$	Area of soil (crawling space) treated per day - private house - public/industrial building	$m^2.d^{-1}$	P/S 131
$AREA_{house(h)}$	Area of soil under the house treated per day (private house)	$m^2.d^{-1}$	D:131
$AREA_{soil}$	Area of soil treated per day - private house - public, commercial, or industrial building	$m^2.d^{-1}$	D 26 126
$AREA_{untreated}$	Area of untreated zone - private house - public, commercial, or industrial building	$m^2.d^{-1}$	P 28 128
$AREA_{wall}$	Area of exterior wall treated per day - private house - public, commercial, or industrial building	$m^2.d^{-1}$	D 125 625
$C_{crawling,soil}$	Concentration of active ingredient in soil under the building	$kg.kgww^{-1}$	O
$C_{prep,soil}$	Local concentration of active substance in soil during mixing/loading	$kg.kgww^{-1}$	O

Symbol	Parameter	Unit	S/D/O/P
$C_{spot,soil}$	Local concentration in soil due to direct release after a campaign (around the treated spot)	mg.kg ⁻¹	O
$C_{spray,flying,soil}$	Local concentration of active ingredient in soil adjacent to the house due to washing and wall application for flying insects	kg.kgww ⁻¹	O
$C_{spray,flying,total}$	Total concentration in soil	kg.kgww ⁻¹	
$C_{spray,nest,soil}$	Concentration of active ingredient in soil	kg.kgww ⁻¹	O
$C_{spray,treatedsoil}$	Concentration of active ingredient in treated soil at 0.5 m from the house due to foundation and ground application against crawling insects	kg.kgww ⁻¹	O
$C_{spray,untreatedsoil}$	Concentration of active ingredient in untreated soil due to foundation and ground application against crawling insects	kg.kgww ⁻¹	O
$C_{spray,wall,wash-off}$	Local concentration of active ingredient in soil adjacent to the house due to washing and wall application	kg.kgww ⁻¹	O
$C_{spray,wall,wash-off,soil}$	Local concentration of active ingredient in soil adjacent to the house due to wash-off by rainfall	kg.kgww ⁻¹	O
$C_{sprayingwall,soil}$	Local concentration of active ingredient in soil adjacent to the house due to wall application against flying insects	kg.kgww ⁻¹	O
$DEPTH_{soil}$	Depth of exposed soil	m	D:0.5
$E_{crawling,soil}$	Local emission from outdoor spray application on crawling space under building	kg.d ⁻¹	O
$E_{prep,soil}$	Emission to soil during preparation step	kg.d ⁻¹	O
$E_{spot,air}$	Direct emission rate of active substance to air from a campaign	g	O
$E_{spot,soil}$	Direct emission rate of active substance to soil from a campaign	g	O
$E_{spray,crawlinginsects}$	Emission during spray application to crawling insects	kg.d ⁻¹	O
$E_{spray,flying}$	Local emission from outdoor spray application on wall due to wall application and wash-off by rainfall	kg.d ⁻¹	O

Symbol	Parameter	Unit	S/D/O/P
$E_{spray, foundation}$	Local emission from outdoor spray application on the foundation	kg.d ⁻¹	O
$E_{spray, foundation, wash-off}$	Local emission related to the wash-off by rainwater of the foundation	kg.d ⁻¹	O
$E_{spray, nest, soil}$	Local emission for one spray application on wasp or hornet nests	kg.d ⁻¹	O
$E_{spray, soil}$	Local emission from outdoor spray application on soil	kg.d ⁻¹	O
$E_{spray, untreated soil}$	Emission from outdoor spray application on soil in untreated area	kg.d ⁻¹	O
$E_{spray, wall}$	Local emission from outdoor spray application on wall	kg.d ⁻¹	O
$E_{spray, wall, wash-off, soil}$	Local emission from outdoor spray application on wall due to wash-off by rainfall	kg.d ⁻¹	O
$E_{spraying wall, soil}$	Local emission from outdoor spray application on wall due to deposition	kg.d ⁻¹	O
F_{AI}	Fraction of active substance in the commercial product	[-]	S
$F_{outdoor, nest powder, soil}$	Fraction emitted to soil during outdoor powder application on ant nest	[-]	D: 0.9
$F_{prep, soil}$	Fraction emitted to ground/soil during preparation step	[-]	P
$F_{simultaneity}$	Simultaneity factor		0.03
$F_{spot, bait}$	Fraction emitted during outdoor bait application	[-]	D: 0.2
$F_{spot, gel}$	Fraction emitted during outdoor gel application	[-]	D: 0.9
$F_{spot, powder}$	Fraction emitted to soil during outdoor powder application on ant nest	[-]	D: 0.9
$F_{spot, soil}$	Fraction of active substance emitted from a campaign to soil		
$F_{spray, air}$	Fraction emitted to air during outdoor spray application	[-]	D: 0
$F_{spray, crawling, wash-off}$	Fraction emitted to soil due wash-off by rainfall	[-]	D: 0
$F_{spray, deposition}$	Fraction emitted to soil during outdoor wall/foundation spray application due to deposition	[-]	D: 0.1
$F_{spray, foundation}$	Total fraction emitted to soil during outdoor foundation spray application	[-]	D: 0.3

Symbol	Parameter	Unit	S/D/O/P
$F_{\text{spray, nest, air}}$	Fraction emitted to air during outdoor nest spray application	[-]	D: 0
$F_{\text{spray, nest, deposition}}$	Fraction emitted to soil during nest spray due to deposition	[-]	D: 0.3
$F_{\text{spray, nest, soil}}$	Fraction emitted to soil during outdoor nest spray application	[-]	D: 0.3
$F_{\text{spray, run-off}}$	Fraction emitted to soil during outdoor wall spray application due to run-off	[-]	D: 0.2
$F_{\text{spray, soil}}$	Fraction emitted to soil during outdoor ground spray application in the treated zone	[-]	D: 0.99
$F_{\text{spray, untreated soil}}$	Fraction emitted to soil during outdoor ground spray application in the untreated zone	[-]	D: 0.0042
$F_{\text{spray, wall}}$	Total fraction emitted to soil during outdoor wall spray application	[-]	D: 1
$F_{\text{spray, wall-ceiling}}$	Fraction emitted to soil during crawling space spray application on wall and ceiling	[-]	D: 0.3
$F_{\text{spray, wash-off}}$	Fraction emitted to soil due wash-off by rainfall	[-]	D: 0.5
N_{appl}	Number of applications	[-]	S
N_{prep}	Number of preparations per day - private house - public, commercial, or industrial building	d ⁻¹	D/S 1 3
N_{sites}	Number of spot treated per house	d ⁻¹	
RHO_{soil}	Bulk density of wet soil	kg _{ww} .m ⁻³	D: 1,700
$V_{\text{crawlingspace, soil}}$	Soil volume	m ³	P
$VOLUME_{\text{soil}}$	Volume of soil exposed - single point of release - other	m ³	0.125 -
$V_{\text{prep, soil}}$	Soil volume for the mixing/loading step	m ³	D: 0.4
$V_{\text{spray, nest, soil}}$	Soil volume for deposition and application at 3 m from the nest	m ³	D: 0.10
$V_{\text{spray, soil}}$	Soil volume around building (flying insects) - private house - public, commercial or industrial building	m ³	P 13 63
$V_{\text{spray, treated soil}}$	Soil volume for deposition and application at 0.5 m (treated) - private house	m ³	P 13

Symbol	Parameter	Unit	S/D/O/P
	- public, commercial or industrial building		63
$V_{\text{spray, untreated soil}}$	Soil volume around building (crawling insects) indirectly exposed to perimeter treatment	m^3	P
	- private house		14
	- public, commercial or industrial building		64
Q_{prod}	Quantity of product applied	kg.m^{-2}	S
$Q_{\text{prod, prep}}$	Quantity of product used for one preparation event	g	S

Summary of variables used in texts and equations in chapter 5 “exposure scenarios for secondary poisoning to wild birds and mammals”

APPL	Application rate	kg.m ⁻²	O
APPL _{ground}	Application rate per square meter (ground)	kg.m ⁻²	O
APPL _{wash-off}	Application rate related to the wash-off of the wall of foundation by rainwater	kg.m ⁻²	
AV	Avoidance factor of contaminated food (1 = no avoidance, 0 = complete avoidance)	[-]	D: 1
BCF _{worm}			
bw	Body weight of indicator species	g	S/P
C	Concentration of substance in fresh diet	mg.kg ⁻¹	S
C _{earthworm}	Concentration of substance in a worm as a result of bioaccumulation	mg.kg ⁻¹	S
C _{spray,wall / foundation}	Local concentration of active ingredient in soil at 1 m from the house due to wall/foundation and ground application	kg.kgww ⁻¹	O
C _{spray,wall / foundation,washoff}	Local concentration of active ingredient in soil adjacent to the house due to washing and wall/foundation application	kg.kgww ⁻¹	O
C _{worm}	Estimate residues in earthworm	mg/kg	S
ETE	Estimated daily uptake of a compound	mg.kg ⁻¹ .d ⁻¹	O
ETE _{acute,crawling}	Estimated daily uptake of a compound to non-target organisms for the acute exposure (crawling insect treatment)	mg.kg ⁻¹ .d ⁻¹	O
ETE _{acute,flying}	Estimated daily uptake of a compound to non-target organisms for the acute exposure (flying insect treatment)	mg.kg ⁻¹ .d ⁻¹	O
ETE _{acute,worm,bird}	Estimated daily uptake for earthworm-eating birds for the acute exposure	mg.kg ⁻¹ .d ⁻¹	O
ETE _{acute,worm,mammal}	Estimated daily uptake for earthworm-eating mammals for the acute exposure	mg.kg ⁻¹ .d ⁻¹	O

ETE _{short-term, herbivorous crawling}	Estimated daily uptake of a compound to herbivorous for the short-term exposure (crawling insect treatment)	mg.kg ⁻¹ .d ⁻¹	O
ETE _{short-term, herbivorous, flying}	Estimated daily uptake of a compound to herbivorous for the short-term exposure (flying insect treatment)	mg.kg ⁻¹ .d ⁻¹	O
ETE _{short-term, insectivorous, crawling}	Estimated daily uptake of a compound to insectivorous for the short-term exposure (crawling insect treatment)	mg.kg ⁻¹ .d ⁻¹	O
ETE _{short-term, insectivorous, flying}	Estimated daily uptake of a compound to insectivorous for the short-term exposure (flying insect treatment)	mg.kg ⁻¹ .d ⁻¹	O
ETE _{short-term, worm,bird}	Estimated daily uptake for earthworm-eating birds for the short-term exposure	mg.kg ⁻¹ .d ⁻¹	O
ETE _{short-term, worm,mammal}	Estimated daily uptake for earthworm-eating mammals for the short-term exposure	mg.kg ⁻¹ .d ⁻¹	O
<i>F_{Ai}</i>	Fraction of active substance in the commercial product	[-]	S
FIR	Food intake rate of indicator species (fresh weight)	g.d ⁻¹	S/P
MAF	Multiple application factor		P
PEC _{oral}	Predicted exposure concentration by oral intake		S
PEC _{soil}	Predicted environmental concentration in soil		S
PNEC _{oral}	Predicted no-effect concentration for oral intake		S
PD	Proportion of food type (vegetation or insects) in the diet of specie of concern (value between 0 and 1; one food type or more types)	[-]	D: 1
PT	Proportion of diet obtained in treated area (value between 0 and 1)	[-]	D: 1
Q _{prod}	Quantity of commercial product applied	kg.m ⁻²	S
RUD	Residue value per unit dose	mg.kg ⁻¹	S/P
T _{appl}	Application rate of active substance	kg.m ⁻²	O